

WILSONWERKS ARCHIVES

This camera manual is for reference and historical purposes, all rights reserved.

This cover page is copyrighted material. This document may not be sold or distributed without the express consent of the publisher.

©2008-2012 wilsonwerks Llc

Protecting all your negatives is as easy as
1, 2, 3 with the new Technal Proof-Printer.

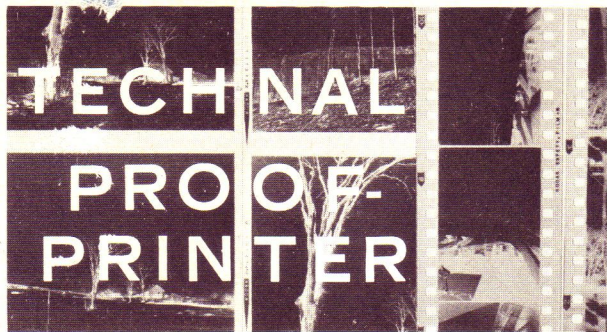

Because the Technal Proof Printer opens like a book, you can insert your negatives face up, holding them in place with the handy press-to-open bronze split-clips mounted on the frame. You can intermix 35mm and roll film negatives; all are held securely in place by the clips.

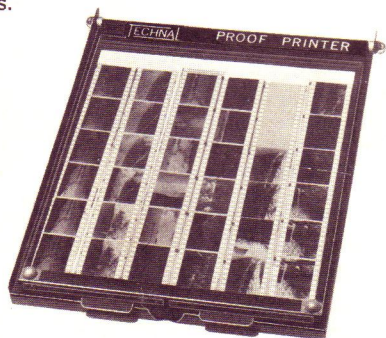
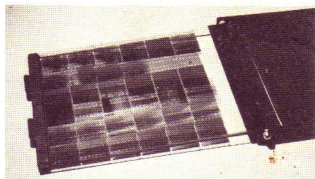

Close the Technal Proof-Printer like a book, and you're ready to expose! The Technal Proof-Printer is the only printing frame which offers both a practical negative hold-down system and the ability to print all sizes of negatives up to 8 x 10 (sub-miniature up to 5 x 7 simultaneously)

Order Code 1887

Only \$14.95

All Prices Subject to Change without Notice

BOGEN PHOTO CORP.

100 So. Van Brunt St. P.O. Box 448
Englewood, New Jersey, 07631

25M172

BOGEN

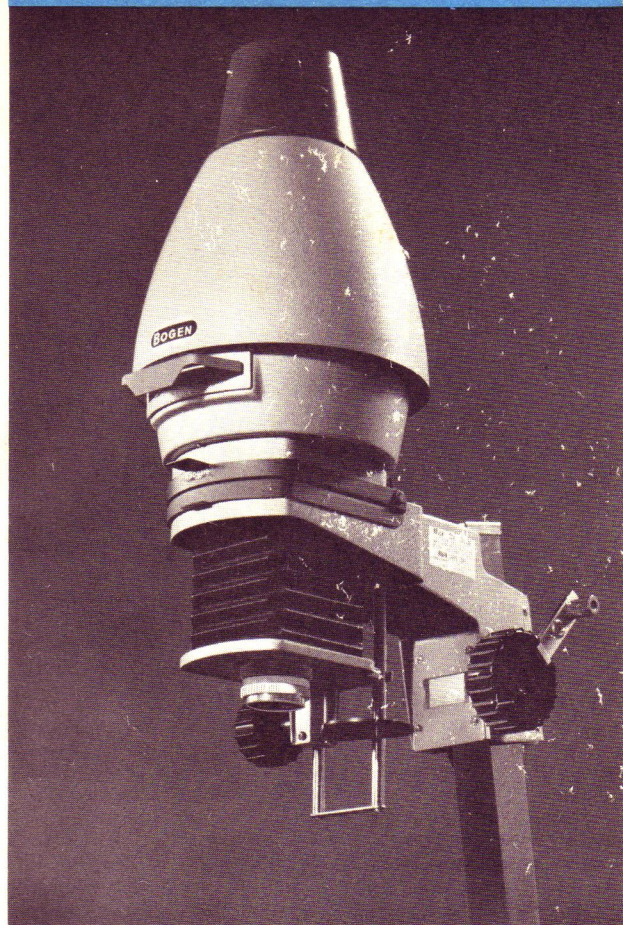

PENN PHOTO SERVICE
1306 N. THIRD ST.
HARRISBURG, PA.

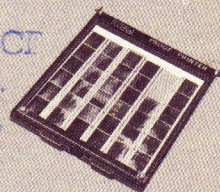

DARKROOM CATALOG



The New Bogen 22A Special makes it easier than ever to get big prints from your 35mm, #126 or 6 x 6 negatives.

The new and improved 22A Special Enlarger combines new ideas, -- such as a foldaway crank for rapid lamphouse elevation, a new simplified column lock which permits instant rotation of the entire head assembly for off-baseboard projection and a new quick two hand focus-elevation system -- with the time proven features such as efficient double condensers, even illumination and built-in color head that made the 22 Special the biggest selling enlarger in our history.



1. Rapid elevating crank folds out of the way for precise height adjustments.

2. High efficiency satin finish internal reflector lamphouse bayonets into place: cannot fall off when enlarger head is tilted for horizontal projection.

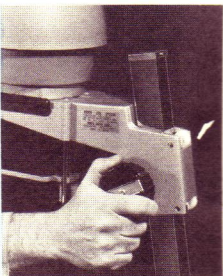

The 22A is a well designed, high quality enlarger at a budget price for the photographer who intends to grow with his hobby. Extremely versatile, it incorporates a built-in color filter head which is equally valuable for printing with variable contrast black and white papers. Individual, complete, glassless, all-metal negative carriers and a range of enlarging lenses from 25mm to 75mm quickly interchange to accommodate negatives from sub-miniature up to 6 x 6 (120) size. The smooth friction drive elevating mechanism permits one hand adjustment of enlarger height, and location of the large focusing knob on the opposite side of the head allows the user to focus and make height adjustments simultaneously to permit accurate framing of the image. Prints up to 11 x 14 inches can be made on the baseboard, and larger prints can be made either by using the swinging head feature for horizontal projection or by rotating the column assembly for floor projection.

SPECIFICATIONS

| NEGATIVE SIZE | RECOMMENDED LENS | MAX. PRINT SIZE ON BASEBOARD |
|---------------|------------------|------------------------------|
| 6 x 6cm | 75mm | 15½ x 15½ in. |
| 35mm | 50mm | 11 x 16¾ in. |
| 126 | 38mm | 16 x 16 in. |

HEIGHT OF COLUMN: 28 in. — MAX. WORKING HEIGHT: 41½ in. — BASEBOARD SIZE: 14⅞ x 17⅞ in. — NET WEIGHT: 11 lbs — LAMP SIZE: #211 Opal.

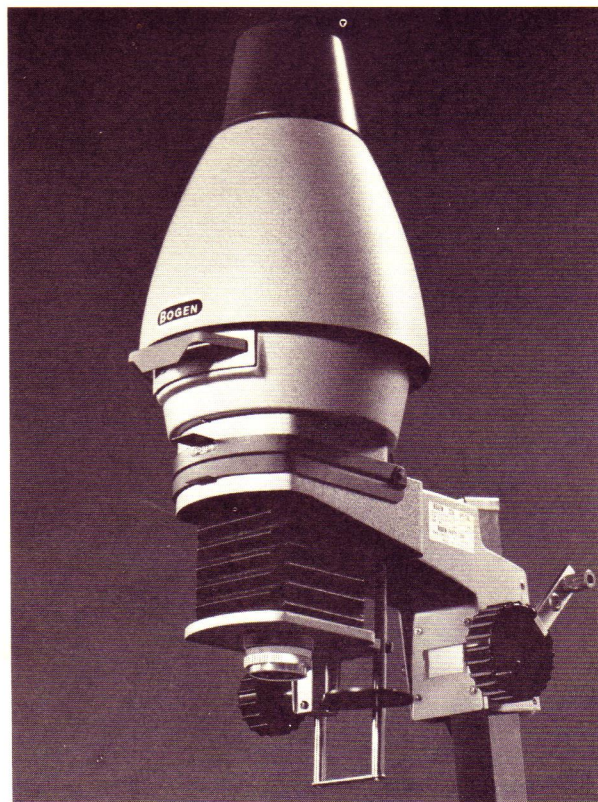

| Order Code Stock No. | DESCRIPTION (All Enlargers supplied less lamp) | PRICE |
|-------------------------|--|----------|
| E22/66 1240 | 22A with 6 x 6 Carrier, less lens. | \$ 78.70 |
| E22/66 1241 | 22A with 6 x 6 Carrier and 75mm f 3.5 Voss Lens. | 89.95 |
| E22/35 1245 | 22A with 35mm Carrier, less lens. | 78.70 |
| E22/35V 1246 | 22A with 35mm Carrier and 50mm f 3.5 Voss Lens. | 89.95 |
| E22/126 1248 | 22A with 126 Carrier and 38mm f 3.5 Voss Lens. | 94.95 |
| E22/HALF 1249 | 22A with 18 x 24 Carrier and 38mm f 3.5 Voss Lens. | 94.95 |
| E22 DUAL 1250 | 22A Special set up for both 35mm and 6 x 6 with separate and complete negative carriers (not masks), and with 50mm & 75mm Voss f 3.5 lenses. (Cost if purchased separately would be \$115.70). | 106.00 |



Accessories

| | |
|---|------|
| Additional Negative Carriers: 18 x 24 (half frame); 126 (Instamatic); 35mm; 4 x 4; 2¼ x 2¼ (Specify Negative size when ordering). | 5.95 |
| 1230 Heat Absorbing Filter for Color or B & W printing. | 3.95 |
| 1231 Vinyl Dust Cover. | 1.50 |
| *less lamp | 3 |

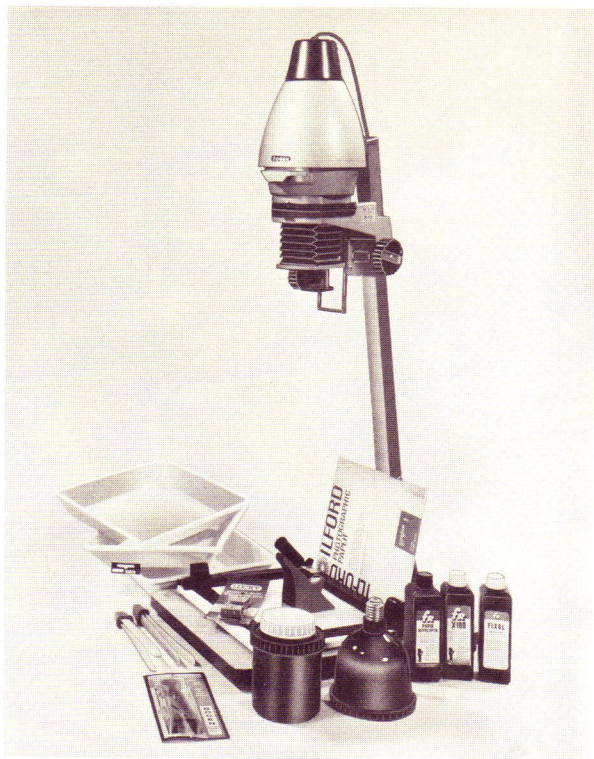

BOGEN 22 SPECIAL DARKROOM KIT

Here, in one convenient group are the important basic items needed to equip a home darkroom for developing and enlarging your own pictures. This kit consists of two cartons. One contains your Bogen enlarger. The other contains the following: BOGEN Precision All Metal 8 x 10 Enlarging Easel With Automatic Paper Grippers and Adjustable margins • Developing Tank with Thermometer • Enlarger Focusing Aid • Darkroom Lamp • G.E. #211 Opal Enlarging Lamp • Pkg. of ILFORD 8 x 10 Bromide Enlarging Paper • 2 Print Tongs • Film Clips • FR Film Developer, Paper Developer and Fixol (1 bottle of each) • 3-8 x 10 Bogen High Impact Developing Trays • FITRO Film Squeegee • Print Paddle Stirring Rod • Dodgette Set.

The total List Price of all of the above items if purchased separately is approximately \$135.00.

Stock No.

| | | |
|------|---|----------|
| 1251 | SS22A Kit with 22 Special and 75mm lens, for 6 x 6 negs. | \$109.95 |
| 1252 | SS35A KIT with 22 Special and 50mm lens, for 35mm | \$109.95 |

VOSS LENSES



Made of the finest optical glass, corrected for spherical and chromatic aberration and free from flare, Lens surfaces are hard coated and designed for flatness of field and high resolution. Diaphragm has click stops.

These lenses are supplied in standard (Leica) thread for enlargers whose lensboards are equipped for this mount.

To adapt to other enlargers order flange listed below. The 25mm & 38mm lenses are supplied in a special recessed mount which permits them to be used in most enlargers which will accept a 50mm lens.

Order

Code

| | | |
|------|---|---------|
| 1801 | 25mm f3.5 Recessed Mount | \$26.40 |
| 1802 | 38mm f4.0 Recessed Mount | 26.40 |
| 1803 | 50mm f3.5 | 18.50 |
| 1804 | 75mm f3.5 | 19.80 |
| 1805 | 90mm f4.5 | 23.76 |
| 1806 | 150mm f4.5 | 47.52 |
| 1810 | LENS FLANGE Adapts enlarger for Leica type thread. | 1.75 |

Voss Enlarging Lenses, SPECIFICATIONS

| Focal length | Range of diaphragm settings | Areas of coverage | Recommended film sizes |
|--------------|-----------------------------|-------------------|-------------------------------------|
| 25mm | f3.5—f16 | 12x18mm | Up to 16mm, central portion of 35mm |
| 38mm | f3.5—f16 | 26x26mm | 35mm: single frame & Instamatic |
| 50mm | f3.5—f16 | 24x36mm | 35mm |
| 75mm | f3.5—f22 | 6x6cm | 127 & 120 (12) |
| 90mm | f4.5—f22 | 6x9cm | 120 & 620 (6x9), 2¼x3¼ S.F. & F.P. |
| 150mm | f4.5—f22 | 4x5 in. | 3¼x3¼ & 4x5 S.F. & F.P. |

SCHNEIDER LENSES

The world-famous Schneider enlarging lenses are considered by many experts to be the best available. They are supplied with a Leica thread adapter ring for the Bogen Enlargers. For other enlargers, a locking nut is supplied.

Order Code

| | | | | | |
|------|---------------|-------|-------|------|----------|
| 1820 | COMPONAR f4.5 | 50mm | | Each | \$ 51.00 |
| 1821 | COMPONAR f4.5 | 75mm | | Each | 57.00 |
| 1822 | COMPONAR f4.5 | 105mm | | Each | 64.00 |
| 1830 | COMPONON f4.0 | 28mm | | Each | 118.00 |
| 1831 | COMPONON f4.0 | 35mm | | Each | 118.00 |
| 1832 | COMPONON f4.0 | 50mm | | Each | 118.00 |
| 1833 | COMPONON f5.6 | 60mm | | Each | 120.00 |
| 1834 | COMPONON f5.6 | 80mm | | Each | 121.00 |

The **NEW BOGEN T-35** is a compact and efficient color enlarger for fine, needle-sharp enlargements of 35mm, 126 and subminiature negatives.

Functional design features include:

- Built-in color head
- High efficiency double condenser system for brilliant, even illumination and extra-sharp details.
- Interchangeable standard screw thread mount accepts choice of coated lenses with click-stops.
- Double track focusing for ease and accuracy.
- Enlarges to 8 x 10 on the baseboard from 35mm, 126 or 16mm.

This remarkably compact unit produces professional results from subminiature, 35mm and 126 negatives. Enlargements up to 20X can be made on baseboard from subminiature negatives; larger prints by wall or floor projection. Precision double condensers and efficient cooling system provide high intensity, sharp illumination without danger to your precious negatives. Complete interchangeability of lenses and negative carriers makes this the ideal tool for the subminiature fan. Compactness is achieved without sacrifice of flexibility or quality.

BOGEN T-35 DARKROOM KIT

Here, in one convenient group are the important basic items needed to equip a home darkroom for developing and enlarging your own pictures. This kit consists of two cartons. One contains your Bogen enlarger. The other contains the following: BOGEN Precision All Metal 8 x 10 Enlarging Easel With Automatic Paper Grippers and Adjustable margins • Developing Tank with Thermometer • Enlarger Focusing Aid • Darkroom Lamp • G.E. #211 Opal Enlarging Lamp • Pkg. of ILFORD 8 x 10 Bromide Enlarging Paper • 2 Print Tongs • Film Clips • FR Film Developer, Paper Developer and Fixol (1 bottle of each) • 3-8 x 10 Bogen High Impact Developing Trays • FITRO Film Squeegee • Print Paddle Stirring Rod • Dodgette Set.

The total List Price of all of the above items if purchased separately is approximately \$105.00.

Stock No. 1470... T-35 Kit \$83.85

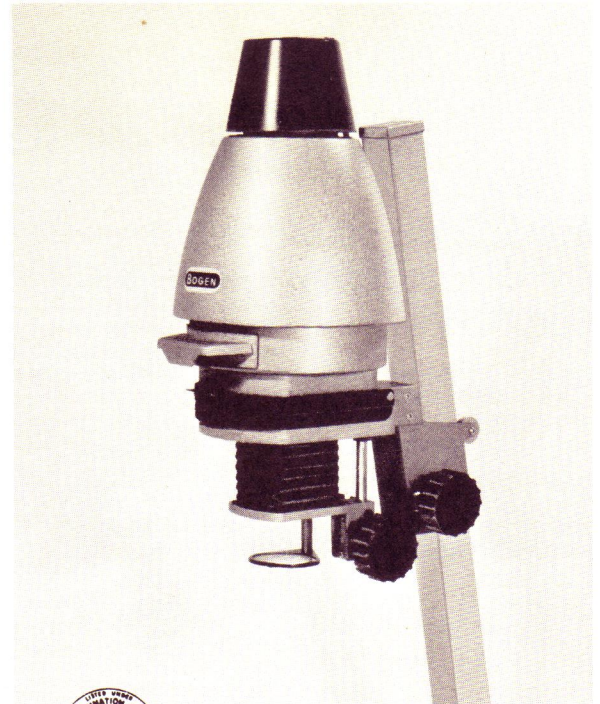

TECHNICAL DATA:

Maximum Enlargement: on baseboard: with 25mm lens 20X
with 50mm lens 8X
off baseboard: unlimited.

Overall height: 30"

Baseboard dimensions: 11" x 13"

Recommended lamp size #211 75 watts

| Order Code Stock No. | DESCRIPTION (All enlargers supplied less lens) | PRICE |
|-------------------------|--|---------|
| T35 1460 | T-35 with 35mm negative carrier, less lens. | \$44.95 |
| T35V 1461 | T-35 with 35mm negative carrier and 50mm f3.5 Voss Lens. | 55.95 |
| T35/126 1462 | T-35 with 126 (Instamatic) carrier and 38mm f3.5 Voss Lens. | 66.95 |
| T35/1824 1463 | T-35 with half frame (18 x 24) carrier and 38mm f3.5 Voss Lens. | 66.95 |
| T35/16 1464 | T-35 with 10 x 14mm negative carrier and 25mm f3.5 Voss Lens. | 66.95 |
| T35/9.5 1465 | T-35 with carrier for 9.5mm (Minox) negatives and 25mm f3.5 Voss Lens. | 66.95 |
| | Extra negative carriers in any of above sizes, each | 5.95 |

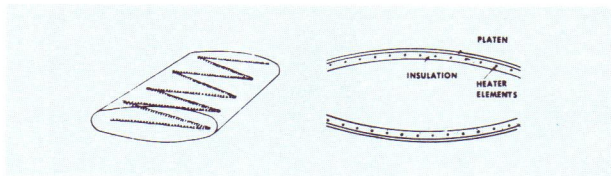

WHY TECHNAL COLOR PRINT DRYERS GIVE BETTER RESULTS WITH BLACK AND WHITE PRINTS, TOO.

Because color prints are so much harder to dry properly, a photo dryer which is built to the rigid specifications of color work will turn out much better black and white prints, even on a high production basis.

Proper high-gloss drying in color prints requires evenly distributed heat maintained to close tolerances and a chrome plated highly polished stainless steel Ferrotypc plate which will maintain its surface integrity indefinitely.

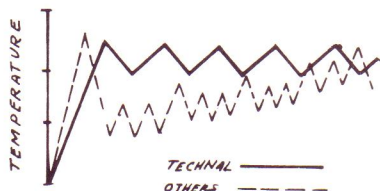

Conventional flat dryers utilize a single heating element strung like an electric toaster between the drying surfaces. These dryers must first waste energy heating a dead air space before any heat gets to the print. Single element heaters, also, must be either on or off and cannot hold temperature within anything but a wide range.

Therefore, to dry color prints on a conventional dryer, the maximum setting must be under the safe limit to avoid overheating, and the dryer is actually off most of the time. By using two sets of dual heating elements, each in contact with the platen, Technal maintains a higher average temperature during the drying cycle without exceeding safe limits, and produces perfectly dried mirror surface prints in less time.

TECHNAL MP Ferrotypc Plates

These premium quality Ferrotypc Plates are made of mirror polished NICKEL STAINLESS STEEL which has been heavily chrome plated. Required for consistent high quality stain free color prints, they are also preferred for Black and White prints because of their extremely long useful life.

MP1217, 12" x 17" Order Code 1885 \$ 6.95

MP1824, 18" x 24" Order Code 1886 \$12.95

TECHNAL #200 TWIN SURFACE COLOR PRINT DRYER.

With Exclusive Dual Heating Elements

- Two 13 x 17½ inch Rust-free aluminum drying platens
- Dual heating elements imbedded under each drying surface
- Pre-tested canvas apron keeps prints flat under spring tension
- Rigid cast aluminum end supports for continuous heavy duty use

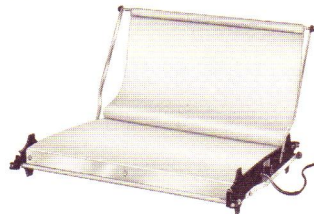

THE TECHNAL #200 Dryer has two rust-free aluminum drying platens and will dry up to two 11 x 14, four 8 x 10, or sixteen 4 x 5 prints at one time. Clips on each surface will accept standard 12 x 17 ferrotypc plates or Technal's accessory MP Chrome Plate Stainless Steel plates for glossy prints.

Specification Model #200:

Power Source Requirement: 115 V., 50-60 cycles A.C.

Power Consumption: 420 watts

Shipping Weight: 9 lbs.

Controls: Temperature control

Drying Area: 13" x 17½" on each of two surfaces

Price: \$29.95

Order Code 1881

TECHNAL #300 STUDIO MODEL COLOR PRINT DRYER.

18 x 24 Twin Surface Dual Heating Elements

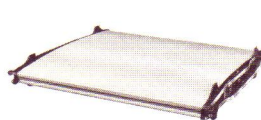

#300

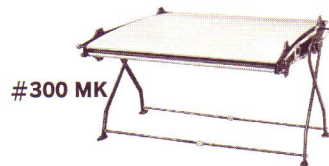

#300 MK

- 18¼ x 24 inch Rust-free aluminum drying platens.
- Dual heating elements in intimate contact with each drying surface.
- Accessory mounting kit permits floor, table or wall mounting.

TECHNAL #300 Specifications:

Power Source Requirements: 115V, 50-60 cycles A.C.

Power Consumption: 750 Watts

Shipping Weight: 20 lbs.

Control: Temperature Control

Drying Area: 18¼" x 24" on each of two surfaces

Price: \$64.95 Order Code 1882

TECHNAL #300 MK

Consists of Technal #300 dryer plus mounting kit, when purchased together

Price: \$79.95 Order Code 1884



The **BIG New TECHNAL 550 DRY MOUNT PRESS** combines an oversize yoke and an **18½ x 22½** platen with a single knob Thickness adjustment.

Do you mount large prints? The Technal 550 has an oversize yoke open on three sides to permit mounting 16 x 20 prints on 20 x 24 boards in one operation; work up to 36 inches wide can be handled in sections.

Technal's precise thermostatic temperature control holds heat to close tolerances in a dial controlled range from 180° to 325° F. A convenient-to-read light indicator tells you when the press is ready.

SPECIFICATIONS

Model 550

Power Consumption 115 V.
60 Hz, 1250 watts

Overall Size (Closed):
25½"W. x 23½"D x 6"H.

Controls: 2 Panel Mounted:
On/Off Switch, Temperature Setting Knob.

Order # 1889 \$219.95

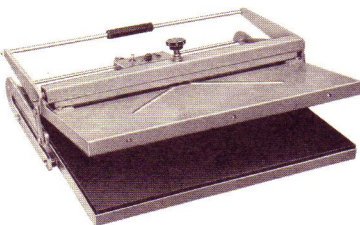

NEW TECHNAL DRY MOUNT TISSUE

For all makes of presses and mounting irons. It sets quickly for permanent mounting; temperature range, 180° to 200° F is safe even for the most delicate color prints. Interleaved with protective tissue.

| Sheet Size | 100 Sheet Box | | 500 Sheet Box | |
|------------|---------------|---------|---------------|---------|
| | Code Order | Price | Order Code | Price |
| 8 x 10 | 1890 | \$ 3.15 | 1891 | \$14.50 |
| 11 x 14 | 1892 | 5.90 | 1893 | 27.00 |
| 16 x 20 | 1894 | 12.30 | 1895 | 56.20 |

Successful Photographers know that a well mounted print is a well presented print. And when it comes to mounting, **TECHNAL** is the name to remember.

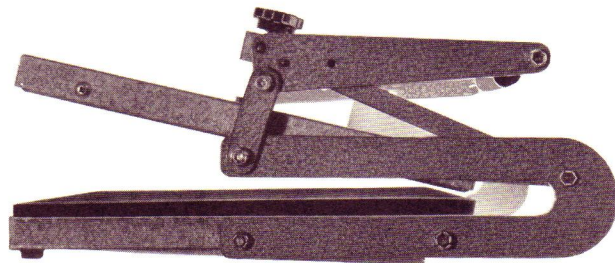

The **TECHNAL 500 Dry Mount Press** is open on 3 sides, has a 12" x 15" platen, provides accurate, thermostatically controlled temperatures from 180° to 325° F., yet costs only **\$119.95**

The new Technal 500 Press has a 12" x 15" heating platen supported on an oversize yoke which permits originals up to platen size to be centered on mounts up to 16 inches wide and processed in one operation. Larger sizes, up to 24 inches in width can be mounted in sections.

The precise control of temperature and extreme evenness of heating assure quick and safe mounting even of fragile and heat sensitive materials such as color prints. A calibrated thermostatic control can be set for any temperature between 180° to 325° F.

SPECIFICATIONS — Model 500

Power Consumption: 115 Volts 60 Hz, 750 Watts
Overall Size (Closed): 18" w. x 17" d. x 6" h.
Shipping Wt: 33 lbs.

Order #1888 \$119.95

New LPL Hi-Impact tanks with stainless steel reels and new handy loader



These New Tanks and Reels Combine Top Quality Construction With Some Good New Ideas At a Price Any Serious Photographer Can Afford.

The tanks for example, are made of chemically inert PVC. The tops can be interchanged without leakage problems and this new plastic is so impact resistant that a blow strong enough to damage it, would probably make a steel tank unusable. The tank tops have a built-in thermometer, easily readable in either Fahrenheit or Centigrade, so you know at any time what the temperature of your solutions is.

The reels are made of high grade stainless steel and are fully compatible with other steel reels made for multiple use.

Loading these new LPL reels makes sense. The 35mm reels are fitted with a positive slot in the center and separate locating pins so that 36 exposure rolls can be loaded with or without the leader removed.

The 120/620 reels have a positive action clip; fumbling with hooks or wire springs is eliminated.

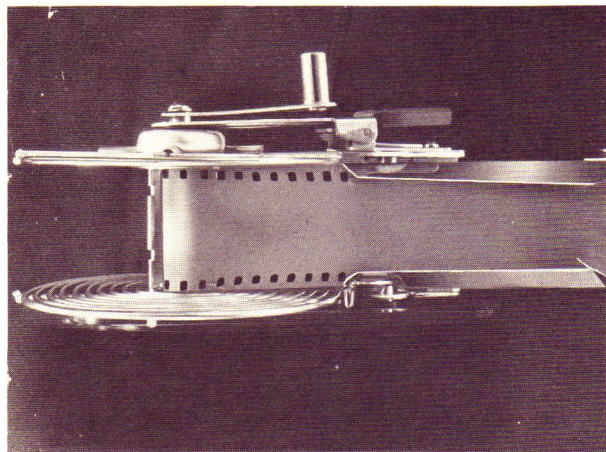

For the 35mm user, LPL has designed a truly Handy Loader for use with its new 35mm reels. It works better than any we've ever tried and it includes such extras as a built-in blade for cutting off leaders evenly and a handy cassette opener. It even doubles as a hand winder for bulk film loading.

| Order Code | | Price |
|------------|---|---------|
| 1550 | LPL 35mm PVC Tank with 36 exp. Stainless Steel Reel | \$ 6.30 |
| 1551 | Additional 35mm 36 exp. Stainless Steel Reels, each.... | 3.30 |
| 1554 | New LPL Handy 35mm Reel Loader with cassette opener and cutting blade | 4.95 |
| 1555 | Combination, 35mm Reel, Tank and Loader | 10.45 |
| 1552 | LPL 16 oz. PVC Tank with 120/620 Stainless Steel Reel | 7.50 |
| 1553 | Additional 120/620 Stainless Steel Reels, each..... | 3.30 |
| 1556 | LPL 16 oz. Tank with 2-35mm Stainless Steel Reels.... | 10.95 |
| 1557 | Combination 16 oz. Tank, 2-35mm Reels and Loader.... | 15.50 |

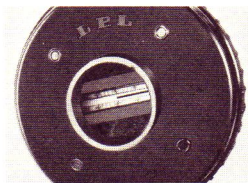

Built-in thermometer is easily visible

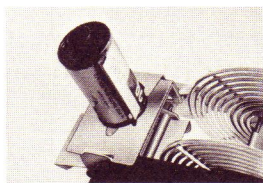

All standard cassettes can be opened with Handy Loader

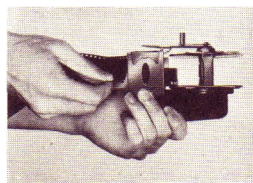

Leader can be removed with built-in cutter

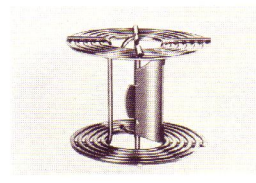

120/620 reel. Note Locking Clip

PHOTO ACCESSORIES

LPL

**NEGA
LUPE**

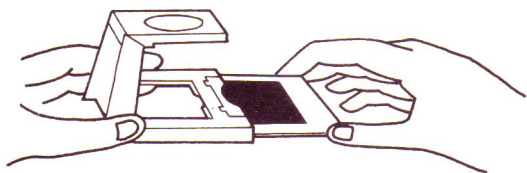
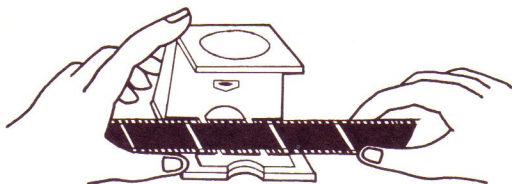
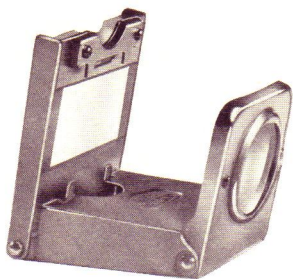

A new idea: an inspection lupe for checking your 35mm negatives for dust and scratches which doubles as a viewer for your mounted 2x2 transparencies. Metal frame folds compactly, opens for use in a jiffy.

Order Code 1571 \$4.50

**PROFESSIONAL
FILM WIPER
SQUEEGEE**



Get excess moisture out of your prints and squeegee them to your ferrotype plates with this new all-rubber molded wiper. 10 inch blade. Massive construction, built to last, easily cleaned.

Order Code 1929 \$5.95

**PRINT ROLLERS
FOR BETTER DRYING**



Heavy duty print rollers, strongly made with smooth acting gum rollers that squeeze excess water out without damaging your valuable prints.

Available in three sizes:

- 6 inch Single Roller Order Code 1930 \$2.40
- 6 inch Double Roller " " 1931 \$3.70
- 8 inch Double Roller " " 1932 \$4.50

LEWCO ENLARGING AIDS

VARIABLE VIGNETTER. Allows an infinite variety of shapes and sizes, including ovals, squares, circles, etc. A choice of the popular notched vignetting opening, or a smooth edge simply by reversing the versatile leaves. During the enlarging, image is projected through the leaves to the paper with the white actinic light only where wanted.

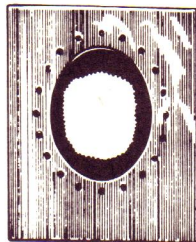

Order #1997 \$2.50

VISIBLE DODGER. A practical accessory for accurately confining spot or local printing, vignetting or dodging to pre-selected areas when projection prints are made. With this positive control of actinic light, portions of a picture can be accentuated, controlled or emphasized, while undesirable details can be eliminated.

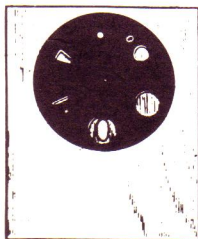

Order #1998 \$3.85

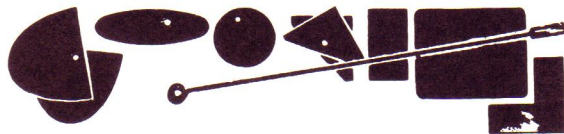

DODGETTE SET. Provides a means of spot dodging or blocking out selected portions of projection prints. Dark areas or objects may be held back and toned down to the desired density.

The set contains a wide variety of shapes and sizes including two versatile adjustable leaves which permit blocking out of practically any shape or size of mass desired.

Order #1999 \$1.50

VOSS ENLARGER FOCUS AID. This ingenious device is an invaluable aid in focusing your negatives. Placed on the easel, it reflects the projected image through a target to a magnifier. You view a magnified aerial image and actually focus on the grain of the negative. It will provide sharp focusing even on blurred negatives, and for both larger and small blowups.



Order Code 1901 \$4.50

FITRO FILM SQUEEGEES



Used throughout the world in professional and industrial processing laboratories Fitro Film wipers are made in West Germany according to a unique, patented design. The three rows of soft rubber wipers on each side gently remove surplus water, hasten drying and eliminate water marks. Because no sponges are used, and because the rubber is not porous, Fitro Squeegees are easy to keep clean. Grit and lint particles cannot embed themselves in the wiping surfaces. A must for the careful worker.

The Fitro-25 Film Squeegee is the ideal all around squeegee for the professional. Its four inch blades are long enough to handle Polaroid P/N or standard 4 x 5 sheet film, supports are flexible to handle smaller sizes. Individual wiper blades can be replaced easily by snapping in a new set.

Order Code 1973 \$ 4.50

Set of replacement blades for Fitro-25.

Order Code 1974 \$ 2.95

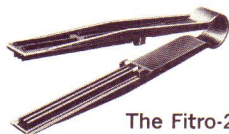

The Fitro-25



Fitro Junior

The Junior Squeegee is ideal for all smaller roll film sizes and cut films up to 70mm in width.

Order Code 1971 \$ 1.95

New — BOGEN HI-IMPACT Photo Trays

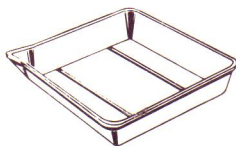

INDESTRUCTIBLE IN NORMAL USE — tough, durable, with superior impact strength. Rugged, yet lightweight; reinforced bottom and rim construction.

NON-CORROSIVE — not adversely affected by chemicals used in photo work; non-porous.

BRIGHT WHITE — for viewing work and inspecting solutions.

OVERSIZE — generous dimensions for easier handling of work.

EASY TO CLEAN — rinse with water or use liquid soap, not abrasives.

NOTE OVERSIZE DIMENSIONS

| ORDER CODE | NOMINAL SIZE | INSIDE HEIGHT | INSIDE WIDTH | BOTTOM LENGTH | PRICE |
|------------|--------------|---------------|--------------|---------------|-------|
| 1980 | 5" x 7" | 1½" | 5½" x 7½" | 1.00 | |
| 1982 | 8" x 10" | 2" | 8½" x 10½" | 2.00 | |
| 1984 | 11" x 14" | 2¾" | 12" x 15" | 4.00 | |

VOSS PRECISION DIAL THERMOMETER

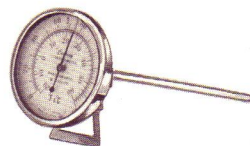

Ruggedly made of stainless steel with 1¾" dial calibrated from 0°-140° F (-20 to 60° C.) Can be used in developing tanks with removable stirring rod, also furnished with stainless clip for tray use. Indexed at 60° and 75° F.

Order Code 1570 \$5.95

VOSS DOUBLE LINED CHANGING BAGS

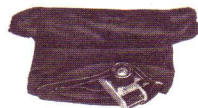

How to get out of a jam without a darkroom! Carry your own portable darkroom with you. These double lined, double zippered changing bags with elasticized sleeves are 100% lightproof. Use them for re-loading your cameras, loading day-light developing tanks when a safe darkroom is not available.

Model A for smaller still and movie cameras: 16" x 17" working space. **Order Code 3402** \$5.35

Model B for professional and general use, 27" x 30" working space. **Order Code 3403** \$9.50

ACE Hard Rubber Photo Trays

SOLID HARD RUBBER — all the way through. Never affected by chemicals used in photo work.

RUGGED — lasts for years. Chip-proof. Reinforced rims, bottom, and pouring lip.

SAFE — for the finest negatives and prints. ACE Trays are non-porous and non-corrosive.

OVERSIZE — generous over-all dimensions permit easier handling of negatives and prints. A real dark-room convenience.

EASY TO CLEAN — just rinse with water.

| ORDER CODE | NOMINAL SIZE | INSIDE HEIGHT | INSIDE WIDTH | BOTTOM LENGTH | PRICE |
|------------|--------------|---------------|--------------|---------------|-------|
| 1990 | 5" x 7" | 1½" | 5½" x 7½" | 1.50 | |
| 1991 | 8" x 10" | 2" | 8½" x 10½" | 2.25 | |
| 1992 | 11" x 14" | 2¾" | 12" x 15" | 4.75 | |
| 1993 | 14" x 17" | 2 1/8" | 15" x 18" | 8.40 | |
| 1994 | 18" x 22" | 2 7/8" | 19" x 23" | 15.05 | |
| 1995 | 20" x 24" | 3 1/8" | 21" x 25" | 18.95 | |

KRYLON PHOTOGRAPHIC SPRAYS

Order Code

1986 Crystal Clear Acrylic Protective Spray (1303) 16 oz. can \$1.95
 1987 Removable Dulling Spray (1310) 16 oz. can 1.95
 1988 Matte Finish. A Permanent dulling Spray (1311) 16 oz. can 1.95

File your negatives and 8 x 10 proof sheet in **BOGEN Vinyl Negative File Pages.**



Made of Specially formulated clear virgin vinyl, these new Bogen Negative File pages make it easy to keep your negatives and proof sheets in one safe place for ready reference and quick retrieval.

Each strip of negatives is kept in its own pocket, and a large separate pocket on the reverse side of the page holds an 8 x 10 proof sheet. Access to the negatives is quick and easy. Pages are die cut with punchout holes to fit standard three ring binders; alternatively, the 9" x 11" size of the page makes for compact and practical storage in standard filing cabinets.

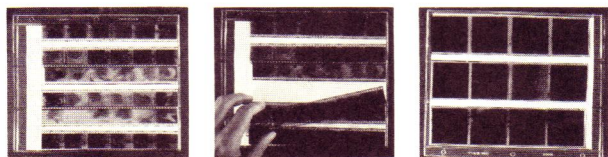

Available in two sizes:

- #2265 For 36 exposure 35mm roll, cut into strips of 6.
Pkg. of 10 \$4.95
- #2267 For 6 x 6 120 or 220 negatives cut in strips of 4.
Pkg. of 10 \$4.95

MARK TIME darkroom timers

#78174 ENLARGER TIMER

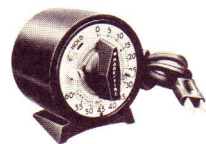

- Adjustable Stop-repeat settings in total darkness
- "On-off" Switch — for focusing
- Push button lock release
- Accurate timings for any period up to 60 seconds
- Built-in electrical outlet

Price \$10.50 Order Code 1939

#56407 THIRTY MINUTE INTERVAL TIMER

This 30 minute timer is ideal for darkroom use. Adjustable stop allows accurate repeat settings in total darkness. Times up to 30 minutes — clear bell tone signals end of pre-set time period.

Price \$7.95 Order Code 1938

BOGEN SEE-THROUGH SLIDE FILE PAGES

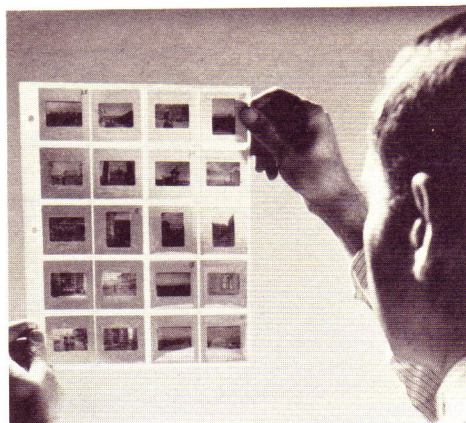

Punched to fit a standard three-ring binder, these vinyl Slide File Pocket Pages are rigid enough for filing in standard folders. To see what is in each page, simply hold it up to the light. The diffusion backing gives even light over the entire slide area.

Available in two sizes:

- #2250 For 20 slides in standard 2 x 2 cardboard mounts. Pkg. of 15, \$5.25
- #2252 For 6 2¼ x 2¼ slides in 2¾ x 2¾ cardboard mounts. Pkg. of 15, \$5.25

MULTICLIP

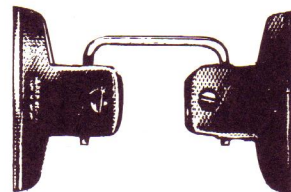

INCHES 1 2 3 4 5

A GREAT NEW IDEA FROM BOWENS!

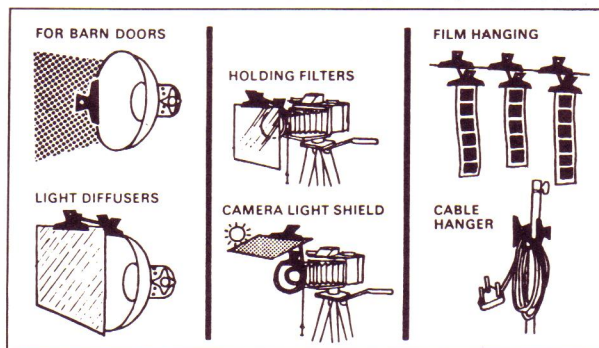

What else can we say except that MULTICLIPS are made in England, you'll find lots of uses for them, and they sell for only \$2.50 each.

While You Are Loading Your Developing Tank, The VIBRO AGITATOR Can Be Mixing Your Favorite Developer Automatically

This Unique New Combination Magnetic Mixer/Developing-Tank-Agitator Is Powered By Two Flashlight Batteries, Presents No Shock Hazard Even In Damp Locations, AND Costs Only \$10.95

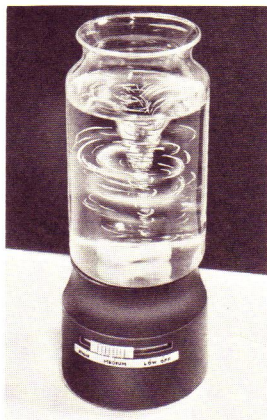

Experts agree that smooth magnetic chemical mixing assures reliable and consistent agitation which yields the finest processed negatives. Magnetic stirring will cause considerable less oxidation of developing agents than the most vigorous hand mixing. Often it allows mixing at lower temperatures, thereby requiring no cooling down to room temperature before use.

You will save valuable time and energy with the double duty Vibro Agitator: it will mix all your solutions and agitate your film during processing too. And to top it off, you'll pay less than half the price of either a tank agitator or an electrically operated mixer alone.

The Vibro Agitator works two ways:

■ For mixing chemicals, just drop the plastic coated mixing bar (supplied) into your glass or plastic beaker. Turn the Vibro Agitator on and adjust the speed until a vortex is formed as the mixing bar spins. Then slowly add your powdered chemicals or liquid concentrate and let the Vibro Agitator do the work for you.



■ Any roll film developing tank, up to 32 oz. size, can be placed on top of the Vibro Agitator. Turn on the adjustable speed switch to Low, Medium or High, and the Vibro Agitator takes over the tedious agitation job.

#1560 Vibro-Agitator, Complete with magnetic stirring bar. Less Batteries (2 "D" size flashlight batteries required) \$10.95

VOSS SUPER AUTO-CLEANER

A newly designed power suction cleaner—not a blower



The Voss Super Auto-Cleaner comes with two easily inter-changed brushes — a round one for cleaning lenses, and a flat brush for negatives. Powered by two penlight cells, the Auto-Cleaner literally sucks dirt off surfaces over which it is passed — without danger of scratching. A built-in dust filter, which can be cleaned and replaced, traps the dirt removed from your lens. One pair of batteries will operate the Auto-cleaner continuously for over an hour, and a built-in on/off switch conserves battery power.

Order Code 1565, supplied with spare filter, less batteries. \$9.95.

LPL Etching Knife.

An excellent etching tool both for negatives and prints. Easy to use, long life blade.

Order Code 1566\$2.00



Long lasting, easily used spotting colors in set of black, sepia and white. Mounted on plastic base.

Order Code 1567\$1.00