

WILSONWERKS ARCHIVES

This camera manual is for reference and historical purposes, all rights reserved.

This cover page is copyrighted material. This document may not be sold or distributed without the express consent of the publisher.

©2008-2025 wilsonwerks Llc

ALL-NEW

Canon 7

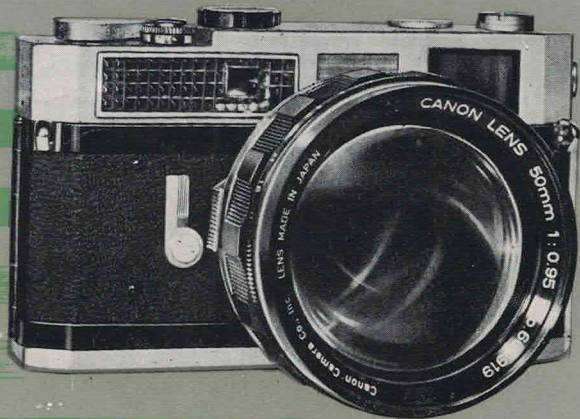

INSTRUCTION BOOKLET

Thank you for buying the Canon 7.

The Canon 7 is the newest and finest member of the Canon family. It is the result of more than 25 years of unique optical and mechanical precision.

We, of Canon, are proud of the Canon 7...and we hope you will be, too.

Sincerely yours,

A handwritten signature in cursive script, appearing to read "T. Mitarai". The signature is fluid and elegant, with a long horizontal stroke at the end.

Dr. T. Mitarai
President

Canon 7

1. Range-Viewfinder Window
2. Lens Depth-of-Field Scale
3. Lens Distance Scale
4. Lens Aperture Ring
5. Canon Lens
6. Illuminating Window
7. Self-Timer
8. Light Meter
9. Film Rewind Ring
10. Exposure Counter Dial
11. Film Winding Lever
12. Shutter Button
13. Film Transport Indicator
14. Shutter Speed Dial
15. Film Speed Indicator Window
16. Film Plane Mark
17. Light Meter Indicator
18. Viewfinder Selector
19. Film Rewind Crank
20. Flash Unit Connector Socket

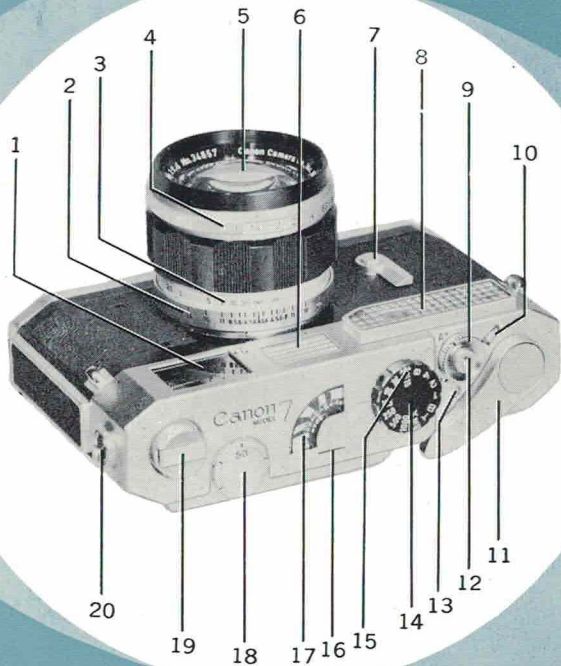

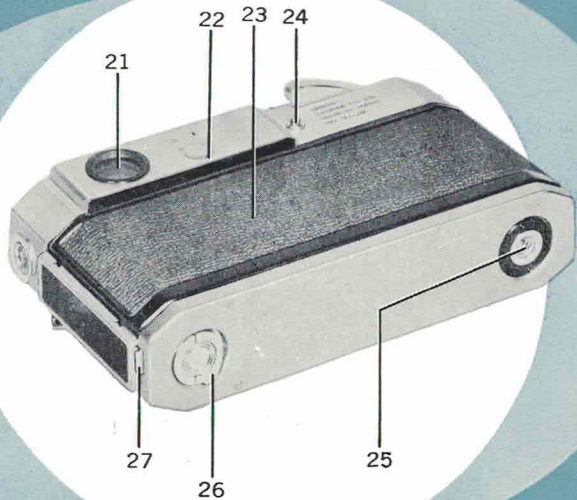

21. Range-Viewfinder Eyepiece
22. Light Meter Sensitivity Shifting Knob
23. Back Cover
24. Film Speed Indicator Button
25. Tripod Socket
26. Magazine Opening Key
27. Lock for Back Cover

Contents

	Page		Page
Canon 7 Specifications	6	Unloading Film	22-23
Winding Film and Cocking Shutter	7-10	Flash Synchronization	24-25
Film Winding		Self-timer	26
Shutter Button		Double Exposures	27
Exposure Counter Dial		Special Care of Lenses	28-31
Shutter Button Safety Device		Changing Lens	
Shutter Button Safety Lock		Distance Scale	
Exposure Setting	11-15	Depth-of-Field	
Setting the Shutter Speed		Infra-Red Photography	
Setting the Lens Aperture		Film Plane Mark	29
Using the Light Meter		Loading Film into the Magazine	32-33
Changing the Sensitivity of the Light Meter		Canon Lenses	34-35
Setting the Film Speed		Proper Care of your Camera	36
Focusing	16-17	To Summarize	37
Range-Viewfinder			
Range-Viewfinder Selector			
Film Loading	18-20		
How to Hold the Canon 7	21		

Model 7 Specifications

Lens :	Model 7 accepts Canon's unique bayonet-mount Canon lens 50mm F 0.95, as well as all thread-mount Canon lenses from 25mm to 1000mm.
Shutter :	All metal focal plane shutter. Single-pivot, rigid shutter speed dial equally calibrated from 1/1000th to 1 sec., B & T plus self-timer.
Exposure Meter :	Built-in light meter coupled to shutter speed dial. Sensitivity range is from LV6 to LV19.
Finder :	Universal viewfinder for 35, 50, 85, 100, and 135mm Canon lenses. Parallax error corrected automatically when focused.
Lens Mount :	New dual mount takes all thread-mount Canon lenses as well as the new bayonet mount 50mm F 0.95.
Focusing :	Double-image superimposing system.
Film Wind :	Single-stroke winding lever.
Exposure Counter :	Self-resetting-type.
Film Rewind :	Rapid crank system.
Film :	Any 35mm film cassette.
Film Speed Indicator :	ASA 6 to 400 (DIN 9 to 27) on the shutter speed dial.
Flash Synchronization :	FP and MX synchronization. Continental-type flash socket.
Size :	140×31×81mm (5-1/2×1-3/4×3-1/8")—body only.
Weight :	About 670 grams (23-ozs.)—body only.

Winding Film and Cocking Shutter

FILM WINDING . . .

Pull the winding lever the full length of its run until it stops. The film will then be advanced to the next exposure and the shutter cocked. At the same time, the exposure counter dial is advanced to the next number.

NOTE:

- Before winding the winding lever, be sure to return the film rewind ring index to the "A" position.

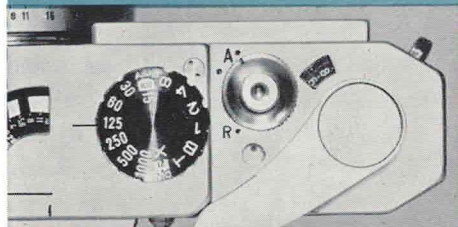
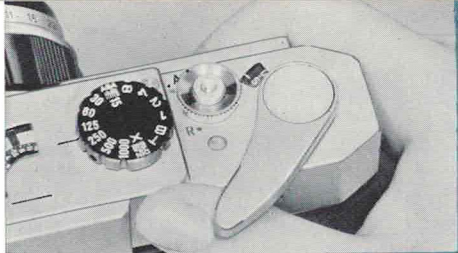

● The lever will return automatically when released. It will not return to the original position, i. e. close to the body. It will be about 1/4"—1/2" from the body. But you can advance the film from this position. When the camera is not in use return the lever to its original position against the body.

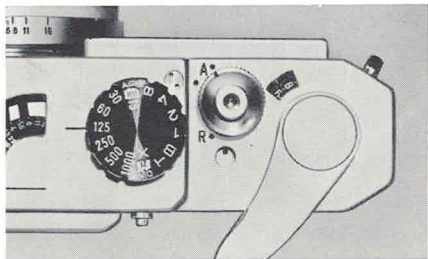

- Several short strokes, instead of one full stroke, can be used to wind the film. The lever locks when winding is complete.
- When the film is loaded, sometimes winding is not completed in one full stroke for the first film wind. If such is the case, the shutter locks and cannot be depressed. To obviate this situation, it is advisable to wind the lever twice for the first film wind.

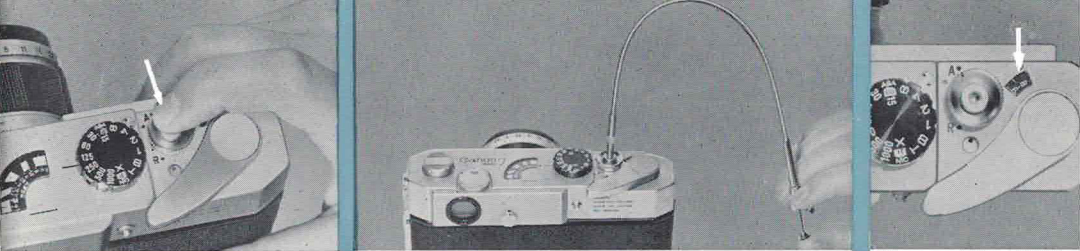

SHUTTER BUTTON ...

When the shutter button is pressed, the film can be wound again with the lever after the shutter is actuated.

- Cable release can be attached to the shutter button.

EXPOSURE COUNTER DIAL ...

The film advanced whenever the film winding lever is completely wound and the exposure counter dial is advanced by one number indicating the number of exposed films. The exposure counter dial returns to the "S" starting position automatically when the back cover is opened.



SHUTTER BUTTON SAFETY DEVICE...

The shutter button's safety device locks the shutter if the film is not completely wound. Unintentional double exposures cannot occur.

SHUTTER BUTTON SAFETY LOCK...

After the shutter is cocked, if you put the index of the rewind ring on the red dot, the shutter button is locked, and you cannot release the shutter even if the button is pressed. This is an added safety device when carrying the camera with shutter cocked. This also enables you to attach the cable release after the shutter is cocked without fear of actuating it.

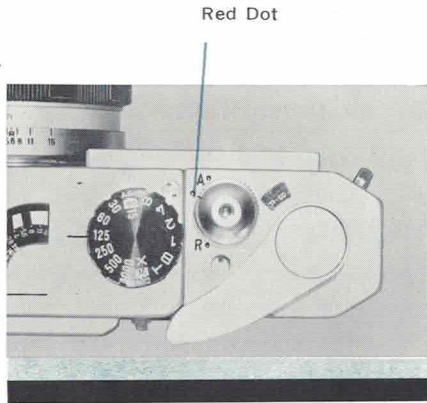

Exposure Setting

Exposure adjustment is done by adjusting the shutter speed and the lens aperture. Correct exposure is easily determined by the coupled, built-in light meter.

SETTING THE SHUTTER SPEED...

Turn the shutter speed dial and set it to the index mark.

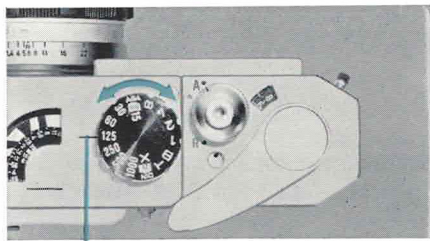

Index Mark

The shutter can be adjusted to speeds of 1 second, 1/2, 1/4th, 1/8th, 1/16th, 1/30th, 1/60th, 1/125th, 250th, 1/500th, and 1/1000th of a second as well as "B" (bulb) and "T" (time) exposures and "X."

The "B" exposure is used for exposures of over 1 second. The shutter stays open as long as the shutter button is kept depressed. The "T" exposure is used for long exposures. When the shutter button is pressed, it will remain depressed, even after your finger is removed, leaving the shutter open. By turning the shutter speed dial slightly in either "B" or "X" direction, the shutter button snaps back into its former position and the shutter closes.

The "X" scale reading is used for speedlight (electroflash) synchronization. The shutter speed is approximately 1/60th of a second; however, the effective time of the exposure in this case depends on the peak performance of the speed light used.

- The figures on the shutter speed dial represent fractions of a second.
- Do not set the shutter speed dial between two figures. It must be set exactly on a "click" stop.

Canon 7

SETTING THE LENS APERTURE ...

The lens aperture adjusts the light volume that reaches the film and also the depth-of-field (see page 30).

The required "F" stop can be obtained by turning the lens aperture ring until the figures align with the index mark.

The following table shows the relation between aperture value and exposure time.

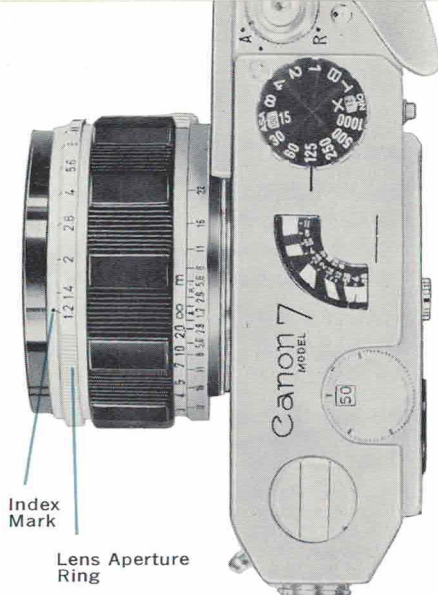

Lens aperture	0.95	1.2	1.4	1.8	2	3.5	4	5.6	8	11	16	22
Relative exposure time	1/4	1/3	1/2	1/1.25	1	3	4	8	16	32	64	128

The figures on the lens aperture ring can be set between two figures.

USING THE LIGHT METER...

When the light meter is faced in the direction of the subject, the needle in the light meter indicator window moves according to the light condition of the subject. The correct exposure can be obtained by following these steps:

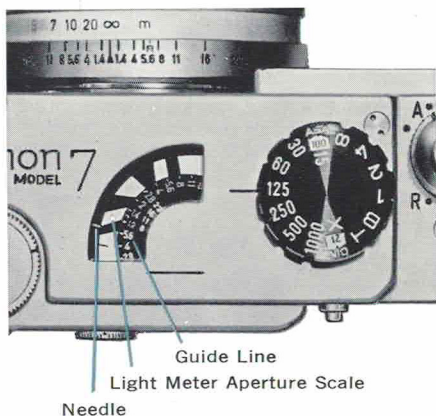

1. When the shutter dial is pre-set to the desired speed: Read off the figure of the aperture scale on the light meter indicator window where the needle rests. Then set the lens aperture ring accordingly.

Follow the black and white guide lines, which are between the needle and the aperture scale, to determine the correct aperture reading. Between the needle and the aperture scale are black and white guide line areas. To obtain the correct aperture scale reading, read from the guide line area opposite the needle.

- For changing the sensitivity of the light meter, see page 14.

2. When the lens aperture ring is pre-set to the desired "F" stop: Turn the shutter dial and match the aperture reading on the meter indicator window to the guide line where the needle rests. The shutter dial should be set where it click-stops.

NOTE:

- The light meter cannot be used for "B" and "T" exposures or when using speedlight.
- When using the light meter, be sure that YOUR HAND DOES NOT COVER THE PHOTOCELL.

CHANGING THE SENSITIVITY OF THE LIGHT METER...

Ordinarily, low sensitivity (black dot) is used for brightness outdoors. High sensitivity (orange dot) for indoors and before-or-after sunset outdoors. If your subject is in so bright a light that it causes the needle to scale out, or when the subject is too dark to give sufficient impulse to the needle, the sensitivity of the light meter is changed by turning the sensitivity shifting knob. If the orange dot on the sensitivity shifting knob is matched to the index mark, indicating the need of high sensitivity (because the subject is dark), the aperture reading must be read off from the orange scale. Conversely, if the black dot is matched to the index mark, indicating the need of low sensitivity (because the subject is too bright), the aperture reading must be read off from the white scale.

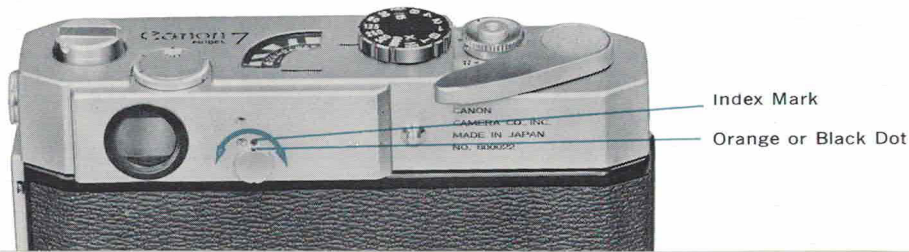

SETTING THE FILM SPEED ...

When using the light meter, the speed of the film used should be set on the film speed indicator window on the shutter speed dial. In order to set the film speed, turn the shutter speed dial while pressing the film speed indicator button. In case the speed of the film used is not indicated on the window, it may be set between two figures.

- Using ASA 100 (DIN 21) film, the sensitivity of the light meter is:

High-sensitivity range (orange dot)	Light Value	6-13 (with F 1.4 1/30 sec. to F 22 1/15)
Low-sensitivity-range (black dot)	Light Value	12-19 (with F 2 1/1000 sec. to F 22 1/1000)

- When the background is brighter than the subject, measure the correct exposure from as close as possible.

(If you cannot get close to the subject, open the lens aperture by one or one-and-a-half clicks.)

Film Speed
Indicator Window

Film Speed
Indicator Button



Focusing

The lens has a “stopper” at the infinity position. Release the lens by pressing the stopper and rotating the lens barrel. The lens will move back and forth by rotating the lens barrel, which is coupled to the rangefinder, enabling you to focus. Canon telephoto lenses do not have a stopper.

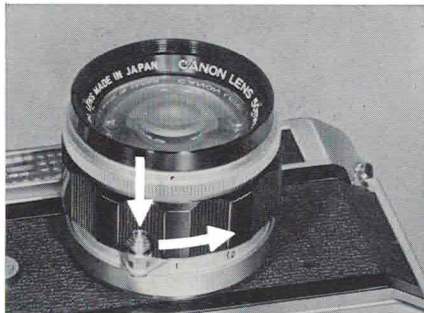

RANGE-VIEWFINDER...

When you look through the range-viewfinder eyepiece and rotate the lens barrel, you will see two images either coincide or remain apart within the comparatively bright circle in the center. When they coincide, your lens is in focus.

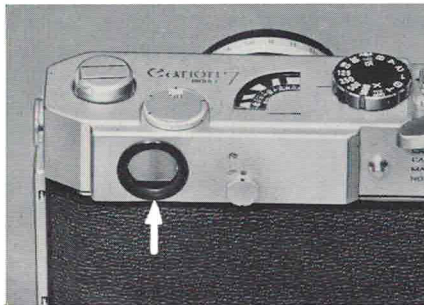



Out of focus

In correct focus



RANGE-VIEWFINDER SELECTOR...

When you look through the range-viewfinder, you will see a white frame and a figure. The figure indicates the focal length of the lens, and the view seen within the white frame in the viewfinder is that which will be recorded on the film. The field of view indicated by a white frame varies according to the focal length of the lens used when the range-viewfinder selector is shifted. The range-viewfinder can be used for the focal lengths of 35mm, 50mm, 85mm, 100mm, lenses. You will see a double white frame for 85mm and 100mm focal lengths. Within the outer white frame is the field of view for an 85mm lens. In the inner white frame area is the field of view for a 100mm lens.

- The white frames are coupled to the focusing mechanism. Parallax compensation is automatic.

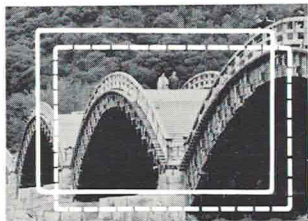

Film Loading



1. To open the back cover, turn the magazine opening key counter-clockwise.
2. Pull down the hinged-back lock while holding the back cover with your fingers. The camera back will then swing open.
3. Rotate the take-up spool until you can slide the end of the film leader into the groove. Then engage the second perforated hole of the leader with the small hook inside the groove. Adjust the film so the film perforation fits the teeth of the film sprocket.

Canon 7 accepts any standard 35mm film cartridge as well as the Canon Film Magazine V, which is available as an accessory.

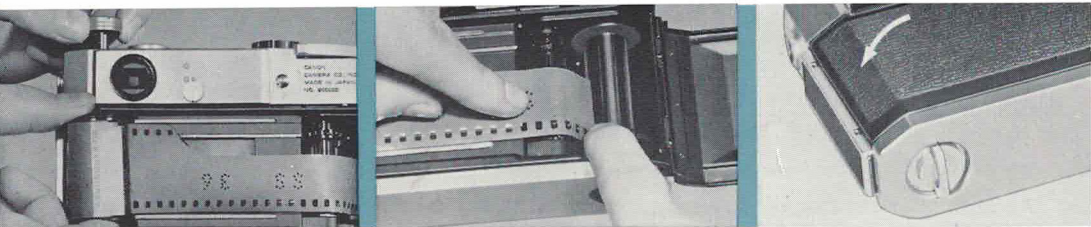

4. Lift up the rewind crank. Put the film cartridge into the recess directly beneath the rewind crank. Press the film rewind crank again to lock the film cartridge in place.
5. With your thumb on the knurled lower end of the take-up spool, turn the spool clockwise until the film is taut.
6. Close the back cover, which locks automatically.

Canon **7**

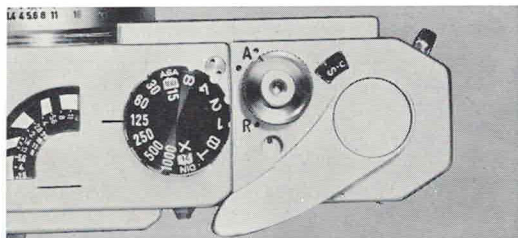

7. Then turn the magazine opening key clockwise to "close," and return the knob to its former position. Do not turn the magazine opening key before closing the back cover.
8. Wind the lever and press the shutter button with the lens cap on. By doing this twice you will have cleared the two frames exposed to the light while you were loading... and the exposure counter dial will advance to "O" from "S." Wind the lever again and you are ready for the first shot.
 - The film is properly loaded and transported if the rewind crank lever rotates when the film wind lever is wound. If the rewind crank lever does not rotate, it means the film was not loaded properly. If such is the case, take out the film -- as illustrated on pages 22-23 -- and reload the film.
 - After you have finished loading the film, be sure to set the speed of film used on the film speed indicator window. Refer to page 15 for setting the film speed.

How To Hold The Canon 7

It is important to hold the camera properly in order to obtain clear-and-sharp pictures. Hold the camera in a vertical or horizontal position . . . look through the viewfinder and focus. Press the shutter button gently after composing your picture. These steps are important:

1. Hold the camera snugly in both hands.
 2. The camera should be pressed firmly to your cheek or forehead.
 3. When using in a horizontal position both elbows should be pressed against your body. In a vertical position, at least one elbow should be pressed against your body.
 4. Hold your breath and press the shutter button with a smooth, steady stroke. If not done in this manner, you will have a blurred picture.
- For exposures longer than 1/30 sec. you should use a tripod and cable release to prevent movement.
 - Do not press on the plastic illuminating window above the lens.
 - The lens hood should be used at all times to eliminate light that is outside the photographic range of the subject.

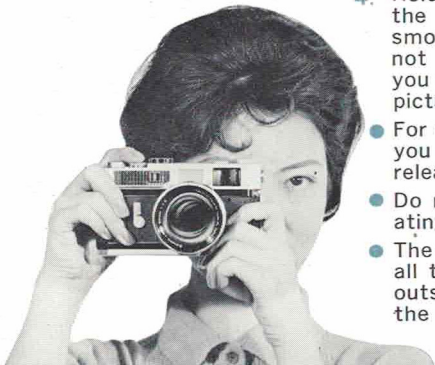

Unloading Film



1. Turn the film rewind ring to "R" from the "A" position.
2. Raise the rewind crank to its operating position and turn clockwise, as shown by the arrow. Watch the rotation of the film transport indicator while rewinding the film. When the rotation suddenly stops . . . then stop rewinding immediately.
3. Return the film rewind ring to "A."
4. Turn the magazine opening key to the left.
5. Open the back cover by pulling the back cover lock outward.

When you have finished a roll of film and you try to advance the film, you will feel tension on your finger. You should then stop winding and remove the film from the camera in this manner :



6. Pull out the rewind crank as far as it will go and take out the film cassette or magazine.
 - Be sure to put the lens cap on before rewinding the film.
 - If the film is forcibly wound after all exposures have been completed, it will be impossible to rewind the film. It will have to be taken out in a darkroom.

Canon **7**

Flash Synchronization

When the Canon Flash Unit V-2 is fitted directly into the flash unit connector socket, and when the shutter button is pressed, it is automatically adjusted for the various shutter speeds of synchro-flash operation.

A lens hood is also necessary when taking flash pictures.

TYPE OF FLASH BULB	SHUTTER SPEED
"EP" Type	"B" 1/1000—1 sec. (except 1/30th)
"M" Type	"B" 1/15—1 sec.
"F" Type	"B" 1/30—1 sec.
Speedlight (Electronic Flash)	"X," "B," 1/30—1 sec.

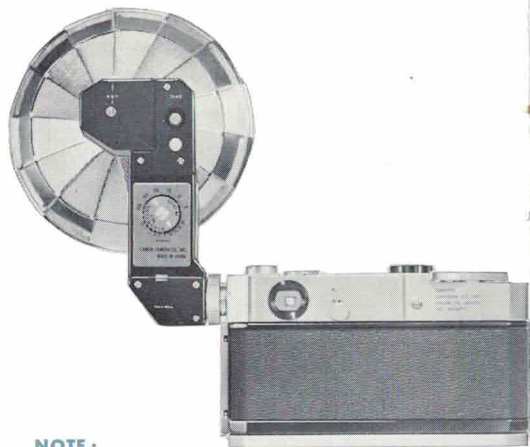

NOTE:

- For electronic flash, turn shutter dial to "X."
- When using miniature size "F" type bulbs (for example: AG1, Philips, etc.), be sure the shutter speed dial is set at 1/15 sec.

Perfect electrical contact is made when the Canon Flash Unit Model V-2 is attached to the flash unit connector socket. No external wiring is necessary and all synchronization is done automatically in the camera itself.

To extend the flash unit from the camera, or to connect a speedlight unit of non-Canon make, use a Canon Extension Cord Va (15-ft.) or Vb (3-ft.)-

When using a clip-on-type speedlight on the Canon 7, the Canon Flash Unit Coupler, or Accessory Coupler, should be used. The Canon Accessory Coupler, which has an accessory clip, is used also to couple the viewfinder when using 25mm or 28mm lens or other accessories with a shoe.

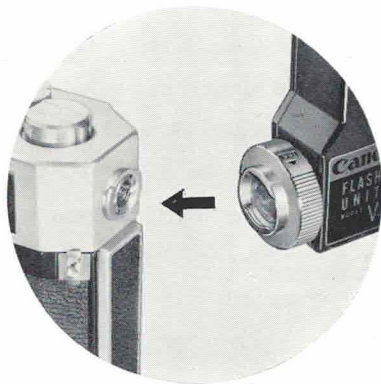

Self-Timer

When you are ready to photograph, turn the self-timer lever counter-clockwise, as illustrated, until it can be turned no further. This can be done before or after cocking the shutter. The timing device will start operating as soon as the shutter button is pressed...and the shutter will be actuated approximately 10 seconds later



- Once you have cocked the self-timer, it cannot be released unless the shutter button is pressed.
- When using the self-timer, it is advisable to use Canon Cable Release, Canon Camera Holder L, and tripod.

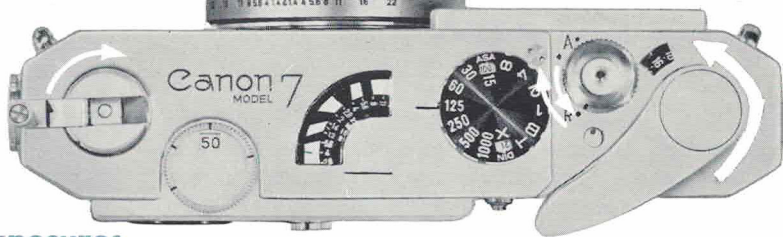

Double Exposures

Canon Model 7 is not designed to take double exposures ; however, it can be done by following these steps :

1. First turn the film rewind ring to "R" from "A" position.
 2. While watching the film transport indicator, turn the film rewind crank to the right and stop when the film transport indicator has made about one-and-a-half turns.
 3. Return the rewind ring to position "A."
 4. Wind the winding lever, and you are ready to expose for the second time on the same film frame.
 5. By repeating the same operation, multiple exposures can be obtained. By turning the film transport indicator two-and-a-half turns, you can make a double exposure on the film before your last one.
- When the shutter button is released accidentally with the lens cap on, the film can be rewound by using this method.

Special Care of Lenses

CHANGING LENS...

The lens mounting flange of the Canon 7 is equipped with both the Canon standard screw-in-mount and Canon special bayonet-mount M. To detach a screw-in-type lens (other than the F0.95 50mm lens) from the camera, hold the lens barrel at its base and turn counter-clockwise (illustrated by small arrow). To replace a lens, keep lens cap on but remove the dust cap from the lens. Turn the lens first counter-clockwise for half a turn to insure that the lens threads and the camera mounting flange do not cross. Next, turn clockwise (illustrated by large arrow) until the lens is securely in place.

- When mounting or dismounting a lens of 85mm or greater focal length, be sure to set it at the nearest footage setting.



Bayonet
Tightening
Ring

To detach a special bayonet-mount-M-type lens from the camera, turn the bayonet tightening ring counter-clockwise (illustrated by small arrow) ... then the lens can be pulled out. To fit the lens into position, match the red mark of the tightening ring to the pin on the lens barrel. Insert the pin of the lens into the hole on the lens mounting flange ... and turn the tightening ring clockwise (illustrated by large arrow) while pushing in the lens.

- Do not change your lens in a strong light. When changing your lens have the replacement lens at hand. Then quickly change the lens in the shade... or use your shadow as a shield from the direct light.

DISTANCE SCALE...

The distance scale indicates the distance between the focused subject and the film. It is not necessary to check the scale for normal photography; however, it is necessary for infra-red photography, which is explained later on, and for determining depth-of-field.



Film Plane Mark...

This line gives you the exact position of the film plane in your camera. To focus on a subject without using the range-viewfinder, a measurement between the subject and the film plane is taken, then the distance index mark is set to the actual distance figure.



Pin
Hole

Film Plane Mark

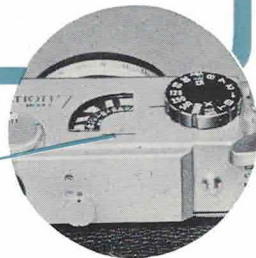

DEPTH-OF-FIELD SCALE . . .

The depth-of-field scale shows you the range of subjects which will be in sharp focus on the film. This range will vary with the "F" stop selected. For example :

The depth-of-field will be deeper . . .

the smaller the lens aperture

the shorter the lens focal length

the farther the distance of the subject

The depth-of-field will be shallow . . .

With an "F" stop of F 5.6, and the subject you have focused on at 25-feet, your camera will give you a sharply focused picture from approximately 16-feet to 55-feet away from the camera. At F 11, you will get a sharp picture from 12-feet to infinity (∞).

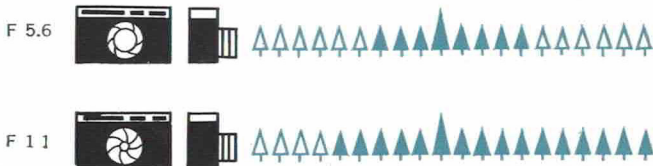

INFRA-RED PHOTOGRAPHY . . .

The letter "R" is on the depth-of-field scale of all Canon lenses. This is for infra-red film. When using this film, focus in the normal way. Read off the distance of the subject you are focusing on as shown opposite the distance indicator mark on the lens distance scale. Turn the lens barrel until the distance reading is opposite the "R" mark. For example: when the subject you have focused on is 25-feet away, turn the lens barrel until the figure 25 is opposite the "R" mark. Your lens is now focused for infra-red photography.



Loading Film Into The Magazine

The Canon Film Magazine V is designed to hold 5-1/4 feet (1.53m) of 35mm film. It consists of three parts: center spool, inner shell, and outer shell.

1. To disassemble the magazine, place your finger on the button and turn the inner shell clockwise until both the inner shell and outer shell slots are superimposed and the safety disengaged. Draw out the inner shell.
2. Insert the tapered end of the film into the larger width slit of the center spool. Face the emulsion (dull) side towards the spindle of the spool.

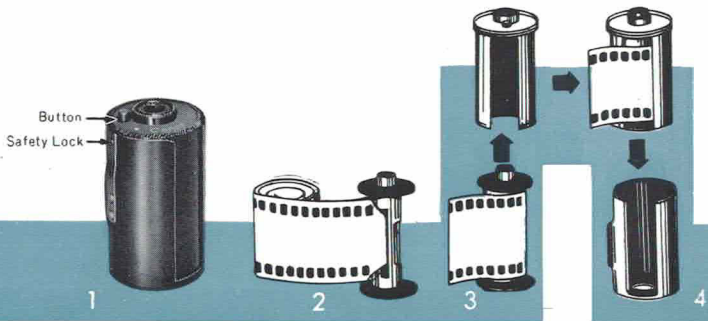
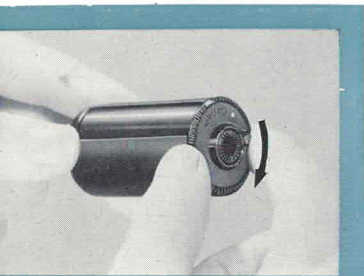

3. Wind 5-1/4 feet of film around the center spool moderately tight for 36 exposures...3-1/4 feet for 20 exposures...3 feet for 18 exposures. Do not touch the emulsion (dull) side with your fingers.
4. To assemble the magazine, first insert the center spool into the inner shell, with the beginning of the film sticking out of the slot.
5. Place the center spool into the inner shell and then place it into the outer shell. Inner and outer shell slots should be superimposed. Turn the inner shell counter-clockwise until it clicks into the locked position.
6. When the film magazine is properly loaded and locked, draw out the film and trim it, as illustrated.
 - This procedure must be done in a dark room or under safe lighting conditions.
 - Keep the magazine in its case when loaded.
 - Keep the magazine clean always.

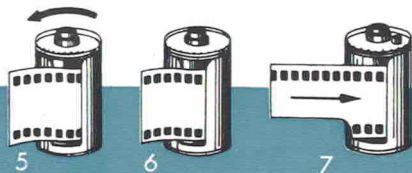

Canon **7**

World-Famous Canon Lenses

Canon lenses are held in the highest esteem by professional and discerning amateur photographers the world over for their unsurpassed, unique optical design and precision engineering. Before leaving the factory, each lens must meet exacting quality tests to insure the highest resolution, contrast, brilliance, and color fidelity. All lenses are Spectra-Coated (TM) internally and externally by a revolutionary process to insure maximum color and tone balance, greater light transmission, and complete elimination of flare.

Today, there are more than twenty kinds of Canon lenses available ranging from 25mm ultra-wide-angle to 1000mm ultra-long-telephoto. With Canon interchangeable lenses, you can photograph anything you wish. The addition of a telephoto lens, or wide-angle lens, makes your camera an extremely versatile one. You can photograph interesting and fun subjects which previously might have been impossible. A whole new field of view will be opened to you with Canon interchangeable lenses.



Specifications for Screw-in Mount Lenses

Type	Angle of View	Magnification	Number of Elements	Net Weight		Aperture (F Stop) Click Stops	Focusing Range	
				(oz.)	(gm.)		down	feet
Wide-Angle								
25 mm F3.5	82	0.5X	5	5	145	22	3.5-50 ∞	1-20 ∞
28 mm F2.8	75	0.56X	6	5.6	160	22	3.5-50 ∞	1-20 ∞
35 mm F1.5	64	0.7X	8	6.5	185	22	3.5-50 ∞	1-20 ∞
35 mm F2	64	0.7X	7	3.8	107	22	3.5-50 ∞	1-20 ∞
Normal-Focus								
*50 mm F0.95	46	1.0X	7	21	605	16	3.5-50 ∞	1-20 ∞
50 mm F1.2	46	1.0X	7	11.4	322	22	3.5-50 ∞	1-20 ∞
50 mm F1.4	46	1.0X	6	8.6	246	22	3.5-50 ∞	1-20 ∞
50 mm F1.8	46	1.0X	6	6.6	188	22	3.5-50 ∞	1-20 ∞
Long Focus								
85 mm F1.8	29	1.7X	5	24	680	22	3.5-60 ∞	1-20 ∞
Telephoto								
100 mm F2	24	2.0X	6	18.3	515	22	3.5-100 ∞	1-30 ∞
100 mm F3.5	24	2.0X	5	7.8	220	22	3.5-100 ∞	1-30 ∞
135 mm F3.5	18	2.7X	4	15.5	438	22	5-100 ∞	1.5-30 ∞
**M135 mm F2.5	18	2.7X	6			22	5-100 ∞	1.5-30 ∞
Long Telephoto								
200 mm F3.5	12	4.0X	7	32	850	22	10-300 ∞	3-100 ∞
**M200 mm F3.5	12	4.0X	7	21.5	610	22	8-150 ∞	2.5-50 ∞
Extra-Long Telephoto								
400 mm F4.5	6	8.0X	5	8.8 lbs.	4 kg.	22	26-600 ∞	8-200 ∞
600 mm F5.6	3.3	12.0X	2	4 lbs.	1.8 kg.	32	17- ∞	5- ∞
800 mm F8	2.5	16.0X	2	4.2 lbs.	1.9 kg.	32	30- ∞	9- ∞
1000 mm F11	2	20.0X	2	4 lbs.	1.8 kg.	32	90- ∞	27- ∞

* Special bayonet-mount M-type lens used for the Canon 7 only.

** Bayonet-mount-type lens used in combination with the Canon Mirror Box 2.

NOTE: Canon lenses from 200mm to 1000mm are available in combination with the mirror box and a complete set of attachments.

Proper Care of your Camera

Moisture and dust are harmful to your camera. It should be taken out into the light and fresh air from time to time.

If your camera is to be stored for a long time, it should be removed from its case. Silica gel or another drying agent should be placed alongside it.

When you use your camera on a rainy day, or at the beach, moisture and salt air adhere to it, which can result in stains, rust, and corrosion.

Use a soft brush to rid the body of dust and a dry, soft cloth for wiping. Do not touch the lens. Use a bellows to blow away dust on the lens or brush lightly with a brush. If you should inadvertently get a fingerprint on your lens and a bellows or brush does not remove the dirt, follow this procedure: use a little pure alcohol, or ether, if available on special lens tissue. Then wrap the tissue around a wooden matchstick and wipe the lens in a circular motion . . . lightly and systematically.



Now That You Are Completely Familiar With Your Camera, Follow These Simple Steps



1. Remove the lens cap

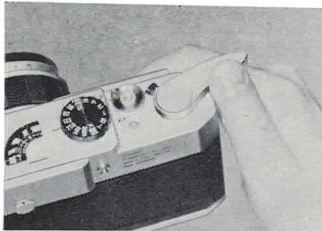

2. Advance the film

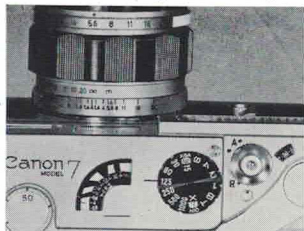

3. Select correct shutter speed and lens aperture



4. Compose your picture



5. Focus



6. Press the shutter button gently

Accessories



CAMERA HOLDER L



CABLE RELEASE



FILTERS



ACCESSORY
COUPLER



SPECIAL VIEWFINDER P



M 200mm F3.5 LENS WITH
MIRROR BOX 2

- FLASH UNIT COUPLER
- EVEREADY CASE
- LENS HOOD
- FLASH UNITS V
and J

Canon

Other Members of the Canon Family



CANONFLEX RM



CANON
MOTOR ZOOM 8 EEE



CANONET



CANON
REFLEX
ZOOM 8-2

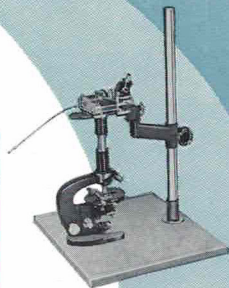

MICROPHOTO UNIT



COPY STAND 3

Canon 7

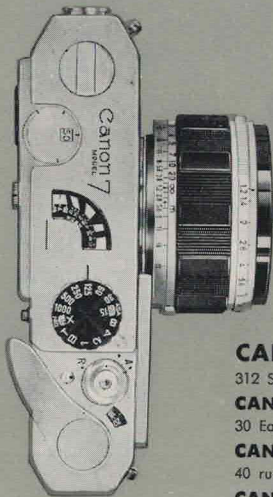

CANON CAMERA CO., INC.

312 Shimo-Maruko-cho, Ohta-ku, Tokyo, Japan

CANON U.S. BRANCH

30 East 42nd Street, New York 17, U.S.A.

CANON EUROPE

40 rue du Stand, Geneva, Switzerland

CANON LATIN AMERICA

Apartado 7022, Via Espana 120, Panama, Republic of Panama

PUB. NO. 5092D

1062D.3

Printed in Japan