

WILSONWERKS ARCHIVES

This camera manual is for reference and historical purposes, all rights reserved.

This cover page is copyrighted material. This document may not be sold or distributed without the express consent of the publisher.

©2008-2012 wilsonwerks Llc

Canon T80

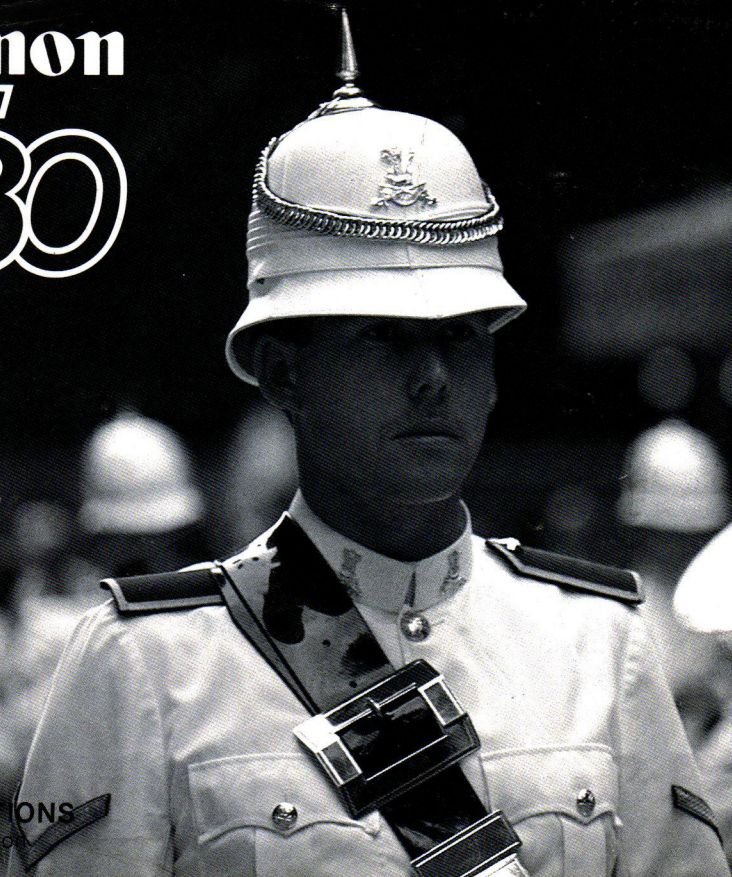

E

INSTRUCTIONS
English Edition



Nomenclature

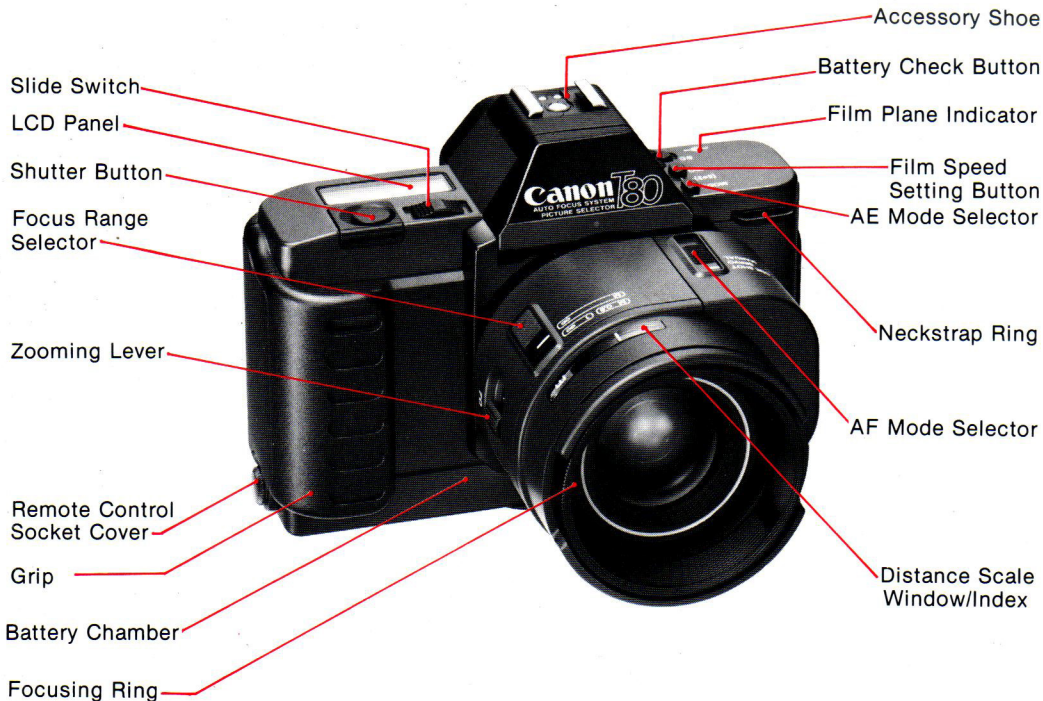

Introduction

Today we live in an age where much of our information comes to us through visual images. The news on TV and in newspapers; advertisements in magazines and on billboards all use pictures. You may not realize it, but these photographs can be differentiated according to which shooting technique was used to take them.

Canon has classified these various techniques into five different types, assigned each a symbolic pictograph, and designed a camera with which you can take a photo by choosing a pictograph. This camera, the

Canon T80, is also equipped with autofocus (AF) so professional-looking, artistic picture-taking is made all the easier.

This instruction book has two parts: the first, "Basic operating procedures" is followed by a more advanced explanation entitled, "Making the most of your T80". The first part explains basic camera handling and shooting. The second part gives a more detailed explanation of various photographic techniques in order to make taking pictures with the T80 fun.

Contents

1. Attaching the Lens6
2. Setting the AF (Autofocus) Mode to "ONE SHOT"8
3. Loading the Batteries8
4. Turning on the Camera10
5. Checking the Batteries11
6. Setting the Film Speed12
7. Loading the Film13
8. Selecting a Pictograph15
9. Holding the Camera16
10. Focusing17
11. Checking for Exposure Warning19
12. Shooting19
13. Rewinding the Film20
14. Self-Timer Photography22
15. Dedicated Flash Photography with the Canon 277T/244T24
16. Carrying the Camera25

BASIC STEPS

In order to fully enjoy your T80, however, it is necessary to read the separate instruction book, "T80 Image Hunting Handbook" at the same time. Please read these instructions thoroughly before using your camera.

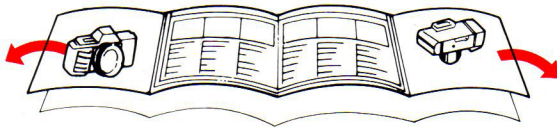

While reading these instructions unfold the front and back flaps of this booklet for easy reference to the camera's parts.

1. Attaching the Lens

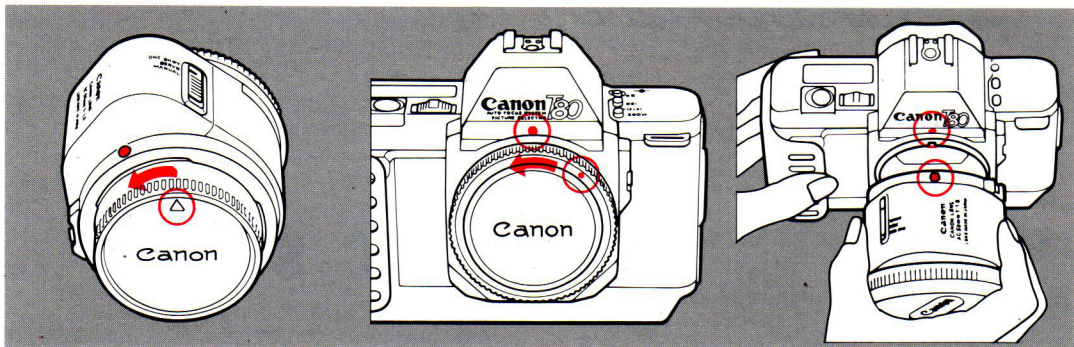

- 1) Turn the rear lens cap in the direction of the arrow until it stops and pull it off the lens. To reattach the rear lens cap, align its arrow with the red dot on the lens. Then lightly push it in and turn it clockwise until it stops.
- 2) Turn the body cap counterclockwise and pull it off. To reattach the body cap, first align its red positioning point with the red dot above the camera mount, then turn the cap clockwise.
- 3) To mount the lens, first align the lens' mount positioning point with the camera's red dot.

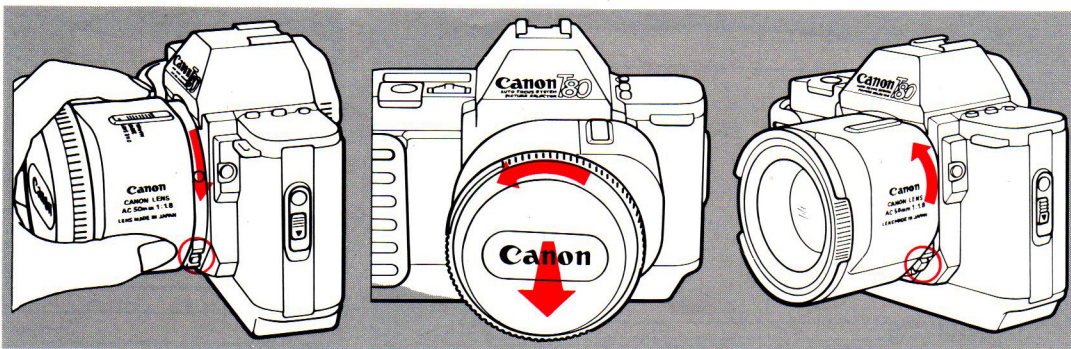

4) Then turn the lens clockwise until it stops and the lens release button pops out with a click.

5) Remove the front lens cap.

To remove the lens, turn it counterclockwise while pressing the lens release button.

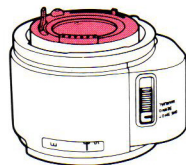

Be sure to place the lens with its front end down (as illustrated) to avoid damaging the protruding pins.

2. Setting the AF (Autofocus) Mode to "ONE SHOT"

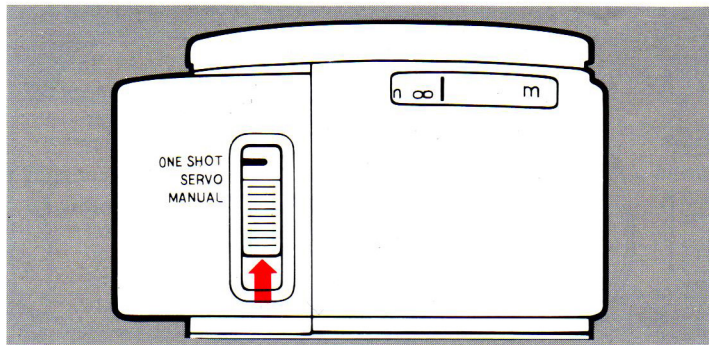

Select the "ONE SHOT" mode for normal use. To select this mode, slide the AF mode

selector on the lens to "ONE SHOT".

3. Loading the Batteries

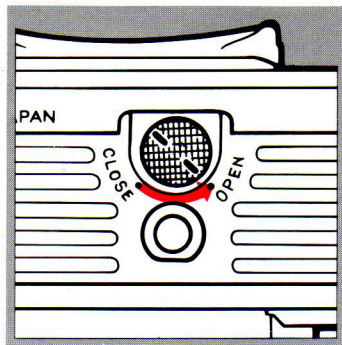

1) Remove the battery chamber cover from the bottom of the camera by turning the open-close knob 90° counterclockwise to the OPEN position.

- For information about the other two AF modes, see page 39 in this instruction book.
- FD lenses can be used, but it is necessary to focus manually and set the aperture ring to the "A" mark.

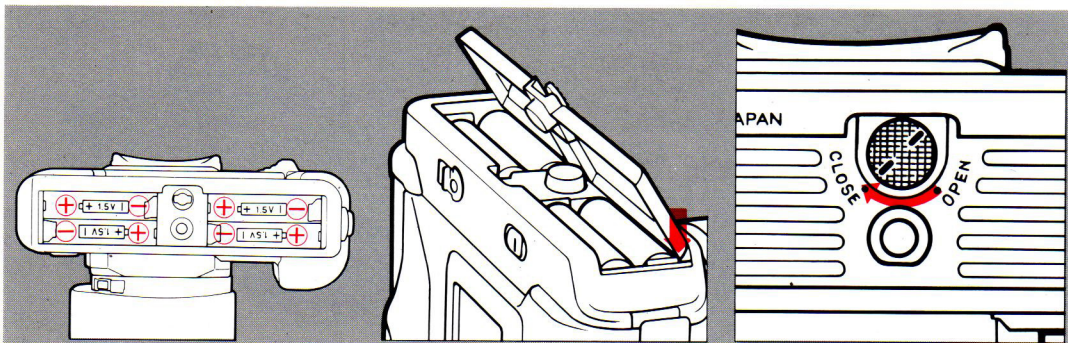

- 2) Load the batteries so that their terminals face in the directions indicated on the inside of the battery chamber. The camera will not function if the batteries are loaded incorrectly.
- 3) Fit the tab on the cover into the groove on the camera and push down.
- 4) Turn the open-close knob clockwise as far as it will go.

- The camera will not function if the knob is not completely turned.
- This camera is equipped with a safety circuit to prevent operation when battery voltage is too low.
- Use four new alkaline batteries (size AAA, 1.5V) of the same brand. Carbon-zinc batteries can also be used.
- Remove the batteries if you do not expect to use the camera for about three weeks or longer.

4. Turning on the Camera

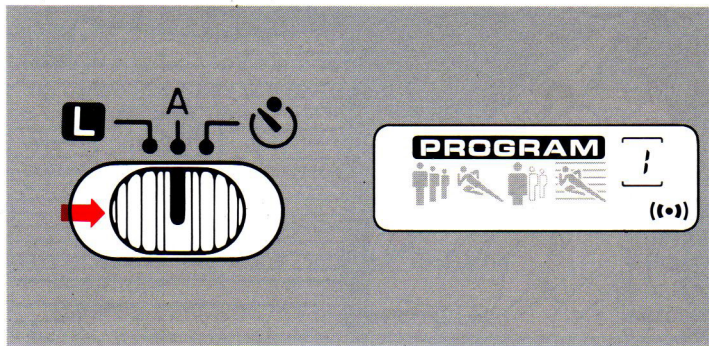

Slide the main switch to “A”. The display will come on at this time.

‘L’ locks the shutter to prevent accidental shutter release. Slide the switch to ‘L’ when not using the camera; this conserves battery power.

‘’ is the position for self-timer photography. (See page 22).

- If the display does not come on, check that the batteries are loaded correctly and the open-close knob is closed completely.

5. Checking the Batteries

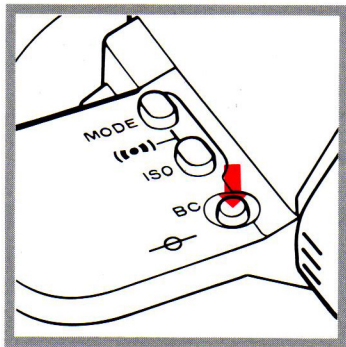

Press the battery check button. Battery voltage is then shown on the display panel.

- For further information about batteries, refer to page 28.

Battery power is sufficient.



(blinking)



Replace the batteries with new ones.

Even if one blinking bar mark or no bar mark appears on the display panel while checking the batteries, exposure will be correct as long as the shutter releases.

6. Setting the Film Speed

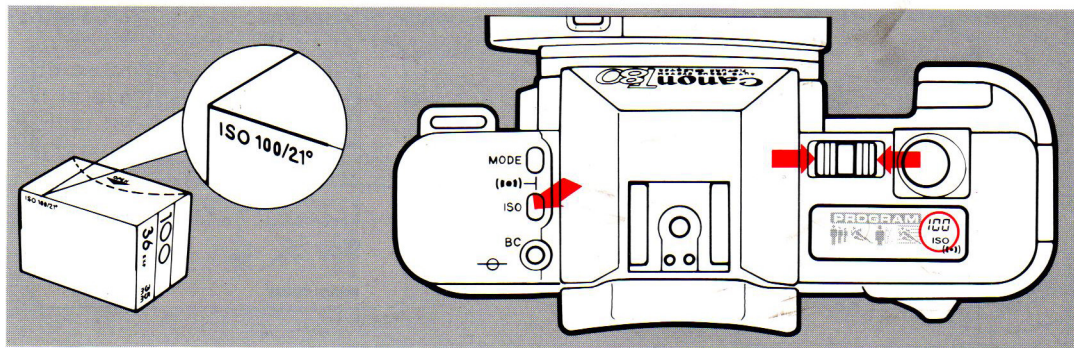

- 1) While pressing the film speed setting button, push the slide switch either left or right.
- 2) Continue to push the slide switch until the ISO value of the film you are using appears on the display panel. (Shift right and values count up, shift left and values count down.)

right →

ISO 12 16 20 25 32 40 50 64
80 100 125 160 200 250
320 400 500 640 800
1000 1250 1600

← left

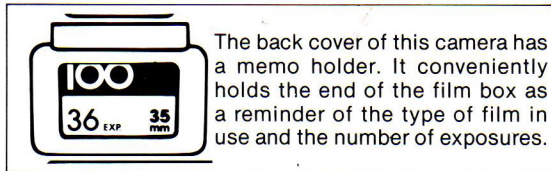

7. Loading the Film

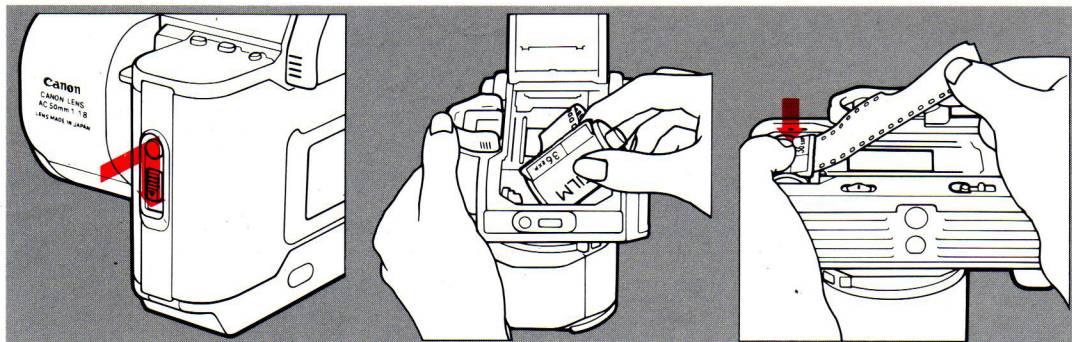

- 1) To open the back cover, push the back cover latch down, while pressing the back cover latch safety lock button in.
- 2) Place the film cartridge in the film chamber. A cartridge symbol will then appear on the display panel to indicate that film is loaded.
- 3) Pull the film leader across the back of the camera until its tip is aligned with the orange index.

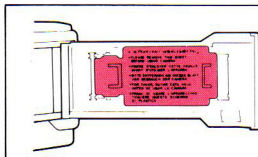

CAUTION:

NEVER touch the shutter curtain. It is sensitive to pressure due to its high precision design. Before loading the first film cartridge, remove the plastic insert and throw it away.

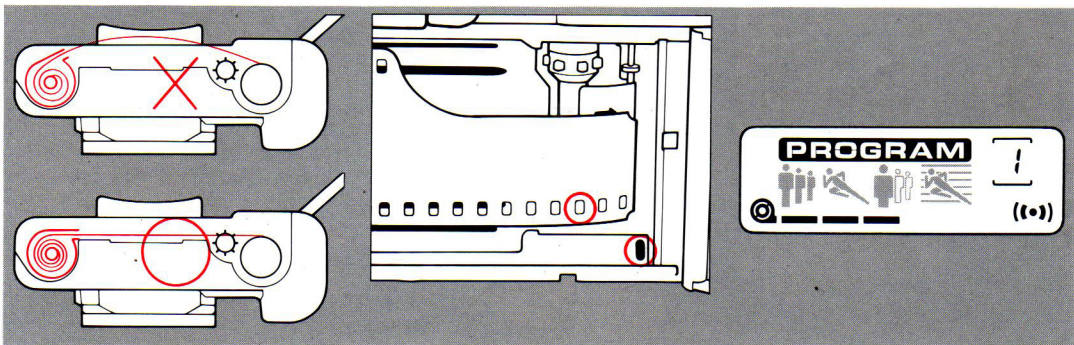

4) Make sure that the film has no slack and that its perforations are properly engaged with the sprocket teeth.

5) Close the back cover. The camera will advance the film automatically and stop when "1" appears in the frame counter brackets on the display panel. If the

film is being correctly advanced, three bars will appear at the bottom of the display panel moving in sequence from left to right away from the film cartridge display symbol.

- The preset film speed will appear on the display panel while the camera is advancing the film.
- If the film has not been correctly advanced, the film transport bars will not appear on the display panel. In that case, reload the film.

8. Selecting a Pictograph

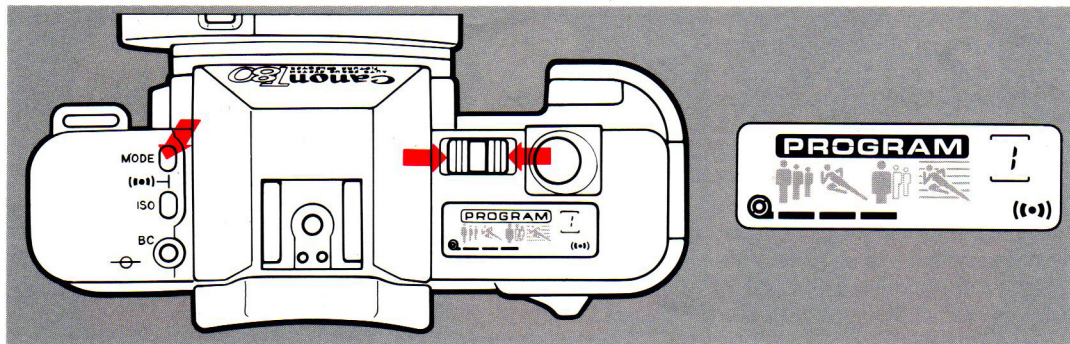

While pressing the AE mode selector, operate the slide switch until “PROGRAM” appears on the panel. It is possi-

ble to select any of the five pictographs; “PROGRAM” is used here as an example.

- For further information about the pictographs, refer to pages 30-34 in this booklet and the separate instruction booklet, “T80 Image Hunting Handbook”.

9. Holding the Camera

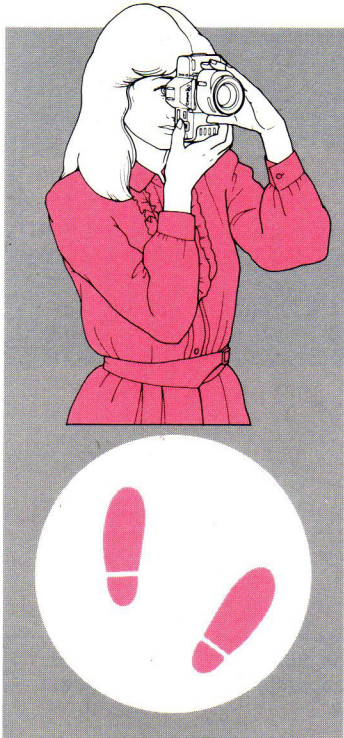

Your pictures will not be sharp if the camera moves when you press the shutter button. This is referred to as “camera-shake.” To avoid “camera-shake”, hold the camera correctly observing the following steps:

- 1) Hold the camera firmly, with your left hand supporting the camera and lens.
- 2) Press your left elbow close to your body.
- 3) Lightly press the camera



against your cheek or forehead and look into the viewfinder.

- 4) Spread your feet slightly apart, one foot ahead of the other, and relax.

There is no one correct way to hold the camera, so experiment to find the most suitable way for you. Select a comfortable, stable method and, if possible, lean against a steady support such as a tree, wall, or table.

10. Focusing

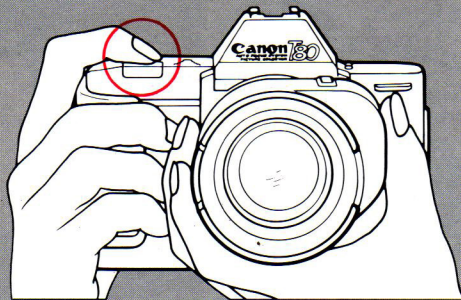
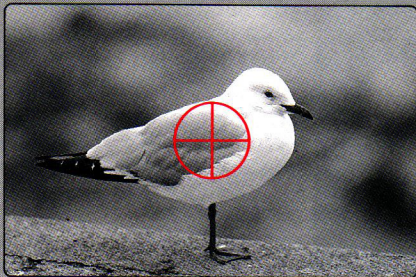

- 1) While looking through the viewfinder, center the AF coverage area (cross-split prism's horizontal line) over the main subject.
- 2) Gently press the shutter button halfway down. AF will operate and focus will be obtained. When focus is obtained, the lens will stop rotating.

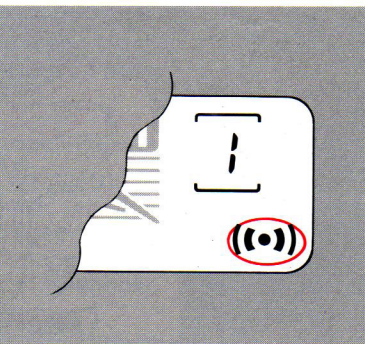
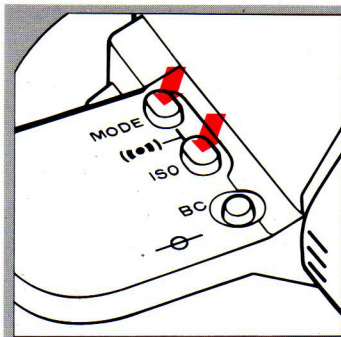

AF focus signal (electronic beeper tone)

If you would like a beeper to sound to signal when focus has been obtained, press the AE mode selector and the film speed setting button at the

same time (holding both down together for approx. 1 sec.) and check the LCD panel to make sure the focus tone symbol appears. The tone can be turned off (and symbol extinguished) by pressing the two buttons again.

- When autofocus is not possible, the lens will continue rotating.
(For further details, see page 39.)

11. Checking for Exposure Warnings

12. Shooting

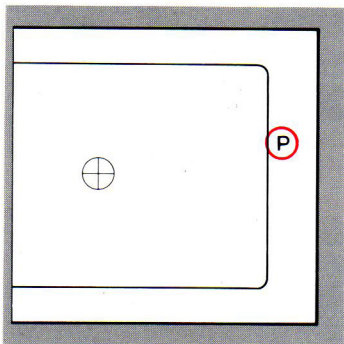

After the beeper sounds, while continuing to press the shutter button halfway, check for exposure warnings. If a solid "P" appears at the right of the viewfinder, you are ready to shoot.

- If the "P" blinks, see page 36.

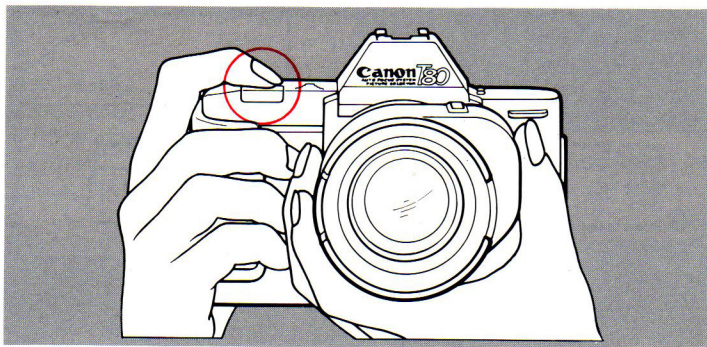

Gently press the shutter button all the way. Pressing too quickly may cause camera-shake.

- To take a single exposure, remove your finger from the shutter button as soon as the shutter is released.
- To take continuous exposures, keep your finger on the shutter button for as many pictures as you wish to take.

13. Rewinding the Film

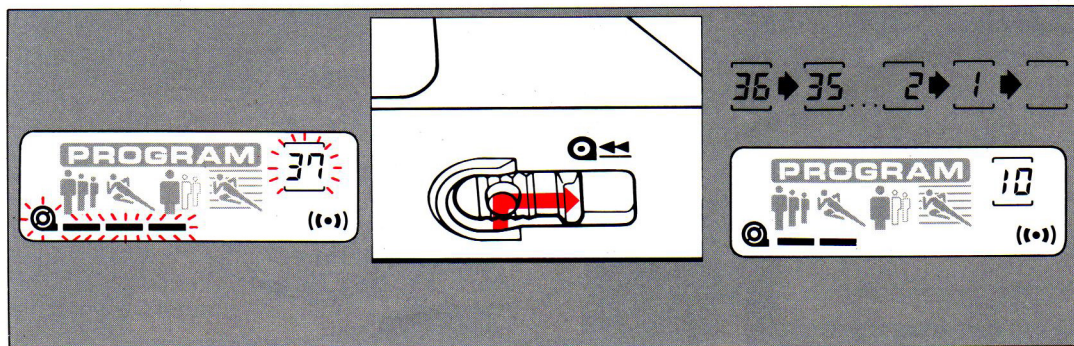

At the end of the film roll, film advance will stop automatically and the camera will beep for about four seconds to inform you that the end of the film has been reached. The frame counter number and the film transport indicator will blink on the display panel at this time.

- 1) While pressing the rewind switch safety lock button, slide the rewind switch to the right.
- 2) The camera will rewind the film automatically and the frame counter will count down. At this time the three bars will move in sequence from right to left towards the cartridge display symbol. Once the camera has started rewinding the film, you may remove your finger from the rewind switch.

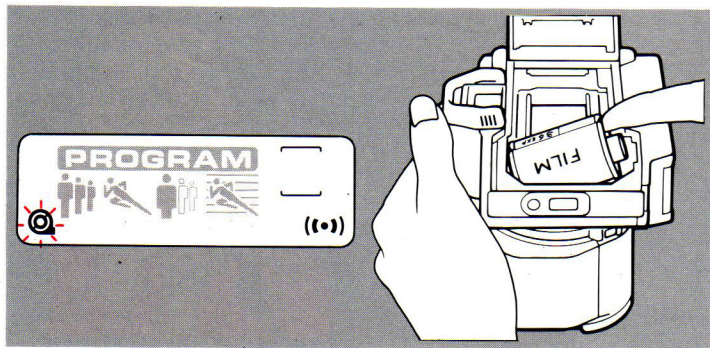

- 3) Film rewind stops automatically when the roll is completely rewound.
 - The camera winds one frame after the end of automatic film rewind.
- 4) When the film-load check mark starts blinking, open the back cover and remove the film cartridge.
Do not open the back cover until the film-load mark on the display panel blinks.

There is an extremely rare possibility that, when the film advance stops at the end of the film roll, the mirror inside the camera body may not flip back to its normal position. If this happens, press the rewind switch safety lock button and slide the rewind switch to the right. The mirror will then return to its normal position.

14. Self-Timer Photography

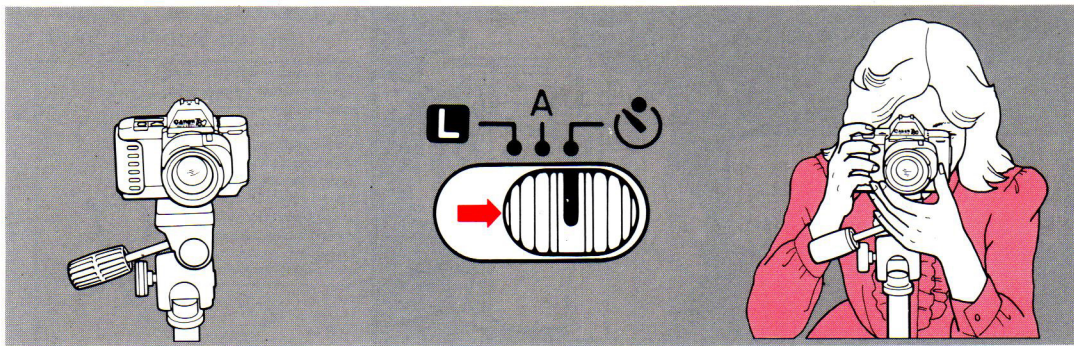

Use the self-timer when you want to be in the picture too. Put the camera on a table, tripod, or other flat surface.

1) Slide the main switch to '⌚' (self-timer).

2) Compose the picture, and focus the subject by gently pressing the shutter button halfway.

3) Make sure the exposure is correct by checking the viewfinder information, then press the shutter button. A beeping sound will be emitted and the frame counter will display the countdown of seconds until shutter release.

If your eye will not be at the viewfinder when you press the shutter button, cover the viewfinder as illustrated to avoid stray light from entering at the rear. Use the viewfinder cover attached to the neck strap shoulder pad for this purpose.

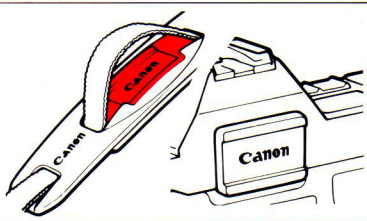

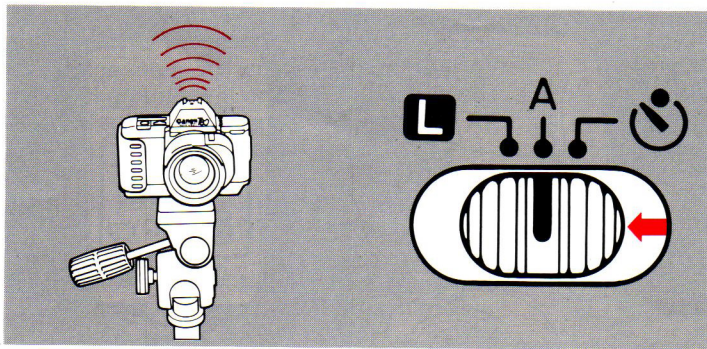

4) The shutter will be released automatically ten seconds after the shutter button is pressed. Two seconds before shutter release, the camera will begin beeping at a faster rate.

5) After release, reset the main switch to "A" unless you want to use the self-timer for the next frame.

Notes

- For self-timer photography, the T80 sets the exposure and the focus the moment you press the shutter button. Therefore, do not stand in front of the lens when you press the button or both focus and exposure may be incorrect.
- If you have started the self-timer and wish to cancel it before shutter release, press the battery check button "BC" or move the main switch off the '⏸' (self-timer) position.

15. Dedicated Flash Photography with the Canon 277T/244T

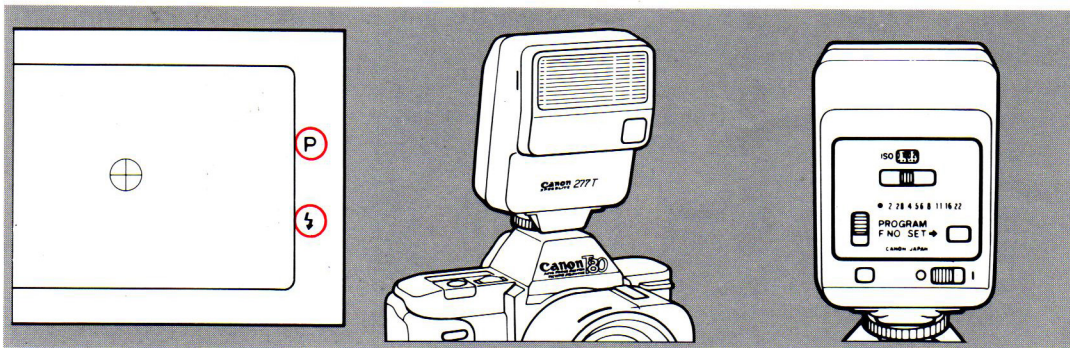

Switch to flash photography when the “P” in the viewfinder starts to blink at 2Hz or 8Hz. For best results, we recommend using the 277T or the 244T with the T80. When using the 277T in the program mode or the 244T, flash photography is just as simple as general daylight photography. Gently press the shutter button halfway. Once the “P” and “⚡” marks signal that the

flash is charged, you are ready for flash photography. (X-sync, 1/90 sec)

- When it is too dark for AF, manual focusing is necessary.
 - The Canon Speedlite 277T can be used as a fill-in flash for daylight photography.
 - For further details, consult the speedlite’s instructions.
- With this camera the use of a Canon flash is recommended. Using another maker’s flash (usually with more than two contacts) or flash accessory may cause the camera to work improperly or even possibly damage the camera itself.

16. Carrying the Camera

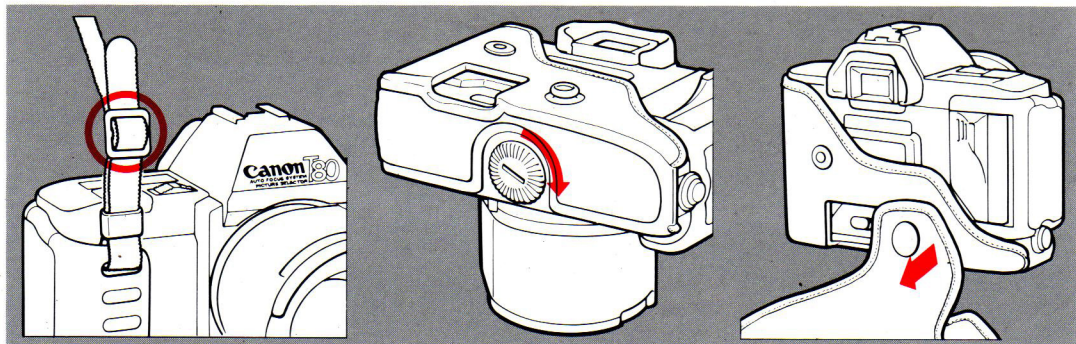

Thread the ends of the strap through the rings on the camera as shown.

To protect the camera while carrying, insert it into its case as shown.

Unsnap the top cover of the case to remove it.



Contents

1. Batteries	28
2. Display Panel and Picture Selector System	30
3. Viewfinder Information	35
4. Selecting the AF Mode on the AC Lens	39
5. Canon AC 35—70 mm f/3.5—4.5 Lens	40
6. Manual Focusing	43
7. Shooting when your main subject is not centered (AF Lock Shooting).....	45
8. Difficult Subjects for Autofocus.....	47
9. Exposure Compensation	50
10. Stopped-down AE Mode (“  ” mark)	51
11. Long Exposure (Bulb) Shooting	52
12. Flash Photography with Other Flash Units	53
13. Remote Control Photography.....	53
14. Accessories	56
15. Caring for Your Camera	60
Specifications	62

Making the most of your T80

1. Batteries



This camera will not operate without batteries. Try to make a habit of checking the batteries at the following times.

- After loading new batteries.
- After storing the camera for a long time.
- If the shutter does not release.
- When you are using the camera in low temperatures.
- Before shooting important events.

Even if one blinking bar mark or no bar mark appears on the display panel while checking the batteries, exposure will be correct as long as the shutter releases.

Use a new set of batteries as specified below or equivalent batteries of another brand.

- Four AAA size 1.5V alkaline batteries LR03 (AM-4)
- Four AAA size 1.5V carbon-zinc batteries R03 (SUM-4)

Notes

- Always use four new batteries of the same brand and replace them all at the same time.
- Wipe the battery terminals and the camera contacts with a clean, dry cloth before loading, to ensure proper contact.
- Remove the batteries if you do not expect to use the camera for about three weeks or longer.
- When shooting in temperatures below 0°C (32°F), keep your camera and spare batteries close to your body or in a pocket to keep them warm until you are ready to take a picture.
- The battery naturally discharges even when not in use, so try to check the batteries regularly.

Shooting Capacity

Temperature	Battery	Alkaline (LR03/AM-4)
Normal (20°C/68°F)		60 rolls 40 rolls
Low (-10°C/14°F)		5 rolls 3 rolls
Low (-20°C/-4°F)		1 roll 1 roll

The upper data is for 24-exp. film and the lower data is for 36-exp. film.

- The life of carbon-zinc batteries is shorter.

2. Display Panel and Picture Selector System

The T80 uses a large liquid crystal display panel to indicate shooting information. The diagram below shows all the information at the same time; however, the display never

actually looks like this. Normally the panel displays only the information required at the time.

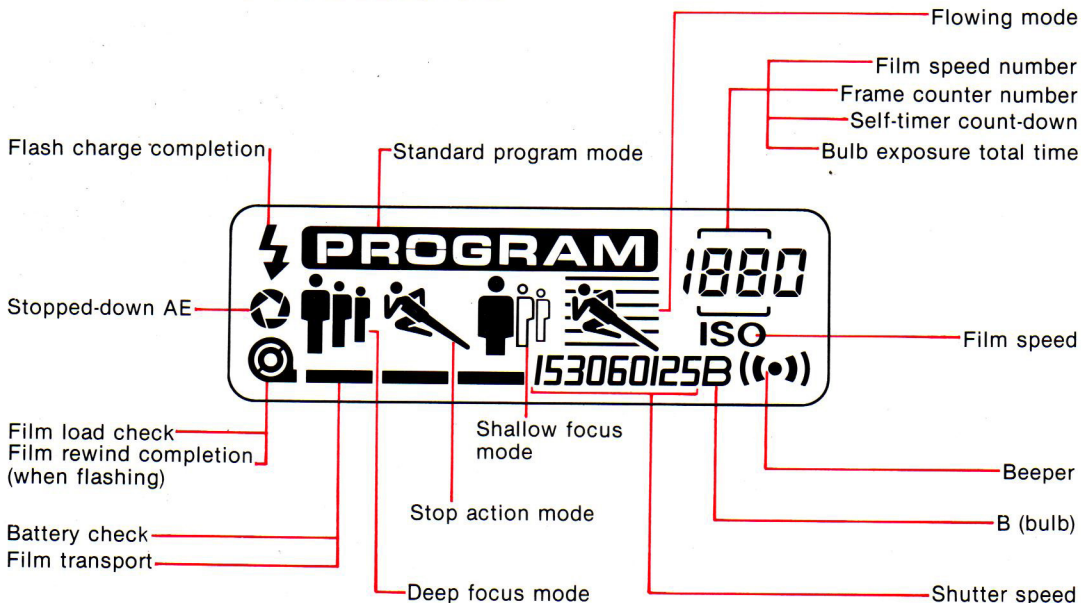

Pictographs and the picture selector system

We are surrounded by photographs in the media and advertising; so many that we take them for granted. But really looking at these familiar images reveals that certain techniques were used in their creation. For the novice, this type of picture may seem out of reach, but with the Canon T80, even beginners can take artistic, professional-looking pictures. The secret is the picture selector system, by which the photographer selects

a pictograph on the LCD panel corresponding to the type of picture wanted and then just presses the shutter button.

Selecting a pictograph

To select a pictograph, push the slide switch either left or right while pressing down the AE mode selector.

- Pictographs are the symbols on the LCD panel representing the different photographic techniques.

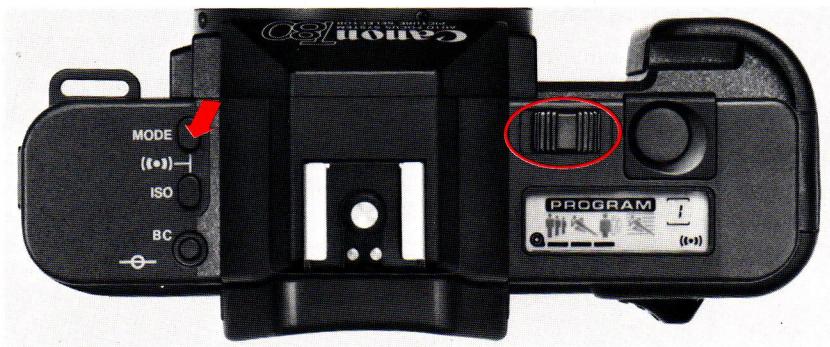

The following pictographs are selectable according to your purpose and the shooting conditions.

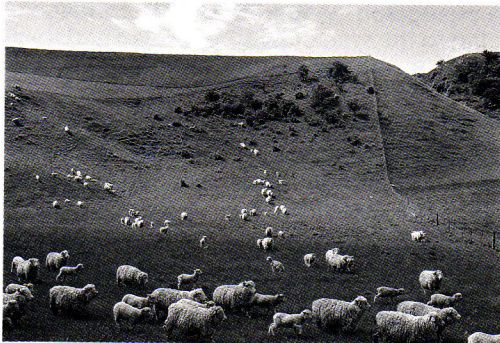

1. DEEP: 

When you want to bring not only the main subject but also the background and foreground into sharp focus.

- For family and group photographs with sharp backgrounds
- For landscape photographs



2. SHALLOW: 

When you want to emphasize your subject by bringing only the main subject into sharp focus and blurring the background and foreground.

- For portraits



3. STOP ACTION:

When you want to freeze subject motion.

- For sports photographs
- For animal photographs
- For race car photographs
- For those who want to avoid camera-shake



4. STANDARD: **PROGRAM**

When a special effect is not necessary.

- For family and group photographs
- For snapshots
- For beginners
- For those who want to concentrate on the subject and not think about the camera at all.

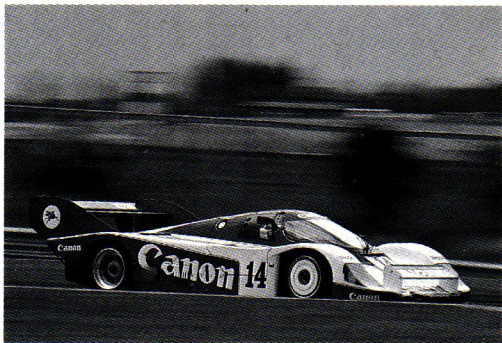

5. FLOWING:

When you want to express the feeling of motion by blurring the background, or the subject, or both.

Selecting a shutter speed in the flowing mode

The numbers under the flowing mode pictograph are for shutter speeds. 15, 30, 60, 125 stand for 1/15, 1/30, 1/60, 1/125 sec. respectively. To set the shutter speed:

- 1) Select the flowing mode by operating the slide switch while pressing down the AE mode selector.
- 2) Next, operate only the slide switch.
 - When you want to blur the background, or both the subject and the background, using the flowing mode, hold the camera and turn your upper body smoothly, following the moving subject, then shoot. (Please refer to the separate booklet "T80 Image Hunting Handbook".)
 - These five AE modes are possible with AC and FD lenses only.

3. Viewfinder Information

This viewfinder is bright and easy to read. Only the necessary information is displayed outside the field of view. The diagram below

shows all the information at the same time for convenience.

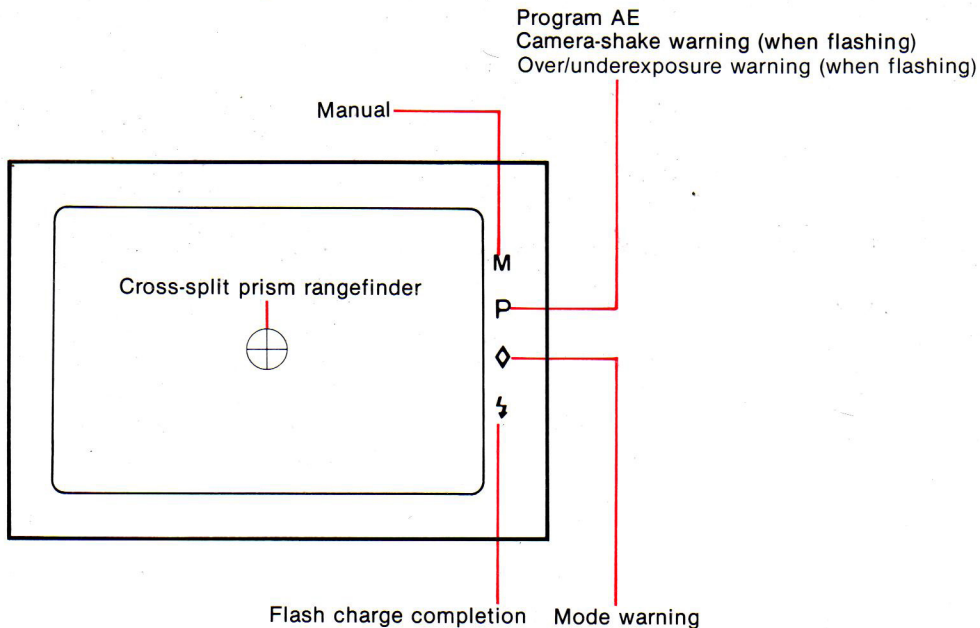

1) Exposure warnings (blinking "P")

If the "P" shines steadily, the exposure will be correct.

When the subject is too bright or too dark for correct exposure or camera-shake is likely to occur, the "P" will blink.

- Taking a picture is a matter of controlling the amount of light allowed to fall on the film. This is called exposure. If the exposure is correct, the picture will look natural, or as we see it with our own eyes. On the contrary, incorrect exposure makes the picture look darker or brighter than it really is.

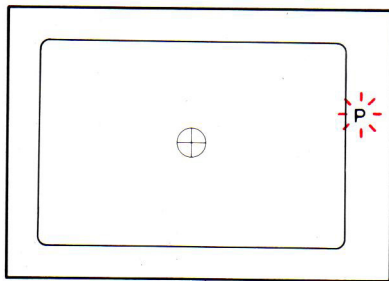

Rapidly blinking "P" (at 8Hz):

Correct exposure is impossible since the subject is too bright or too dark.

- When the subject is too bright, use an ND (neutral density) filter.
When the subject is too dark, use the Canon Speedlite 277T or 244T.

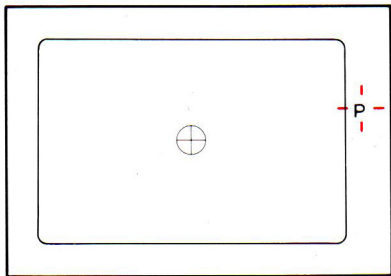

Slowly blinking “P” (at 2Hz):

Camera-shake warning. Use the Canon Speedlite 277T or 244T, or put the camera on a tripod. (Blinks for shutter speeds of slower than 1/30 sec.)

Very slowly blinking “P” (at 1Hz):

Camera-shake warning. Hold the camera firmly. (Blinks for shutter speeds less than 1/90 and greater than and including 1/30 sec.) When using a telephoto lens such as the AC 75—200mm f/4.5, be especially careful to hold the camera steady if the “P” blinks very slowly.

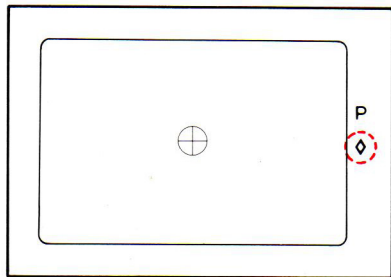

2) **Mode warning (steadily shining “◇”):**

The AE program in use has reached its limit and the desired results cannot be obtained. If the “◇” lights up and the “P” does not blink at 8Hz, however, exposure will still be correct and you will get the best possible results under the existing shooting conditions.

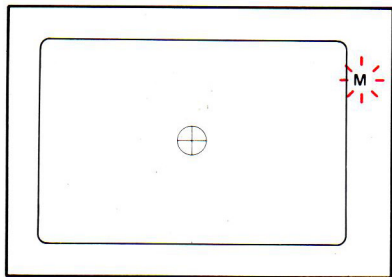

3) Manual indicator (blinking "M"):

A blinking "M" will appear when the manual mode has been chosen.

- When using an FD lens with the aperture ring removed from the "A" mark.
- When a flash is set to manual, even if the lens is set to the "A" mark.
- When making long exposures. (See page 52.)

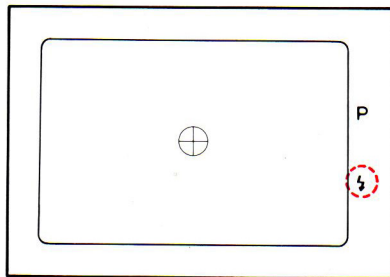

4) Flash charge-completion (steadily shining "⚡"):

With a Canon Speedlite, the "⚡" will light up when the flash is charged.

4. Selecting the AF Mode on the AC Lenses

The following AF (autofocus) modes are selectable according to your purpose and the shooting conditions.

Select:

- “ONE SHOT” for normal use, and for focus-lock photography.
(For more information about focus-lock see page 45.)

In this mode the lens stops rotating once focus has been obtained. As long as you continue to press the shutter button halfway down, even if the camera is pointed at another subject at a different focusing distance, the original focus will remain locked.

- “SERVO” when you want to freeze subject motion at a certain moment while following a moving subject.
When following a moving subject in the Servo mode, the lens continues to rotate, refocusing every time the focusing distance changes.

- When taking continuous exposures, the original focus will remain locked for all the shots, even if the focusing distance changes.



- The autofocus system's response speed changes depending on such shooting conditions as brightness. Response speed becomes slower as it gets dark. In low temperatures battery power becomes lower so response speed is slower.
- “MANUAL” for manual focusing.
In this mode the subject is focused by rotating the manual focusing ring. When autofocusing is impossible, select the manual mode by sliding the AF mode selector to the “MANUAL” mark.

5. Canon AC 35—70mm f/3.5—4.5 Lens



The following explanations refer to the Canon AC 35—70mm f/3.5—4.5 lens. If you have the T80 with the Canon AC 50mm f/1.8, proceed to page 43.

Zooming

The focal length of the AC 35—70mm f/3.5—4.5 lens can be varied using the zooming function. By changing the focal length you can adjust image size to obtain the desired composition. Zoom by rotating the zooming lever which is located on the underside of the lens.

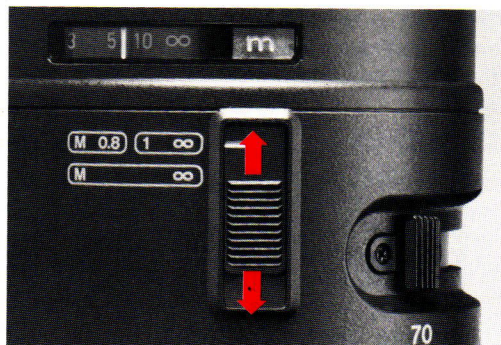

Selecting the autofocus range

You can select three autofocus ranges according to your purpose. To set the focusing range, first rotate the focusing ring until it is set in the desired range and then slide the focus range selector until it is aligned with the same range.

The following ranges are selectable:

Select:

Macro— ∞ : for normal use and when you cannot estimate the distance from the lens to your subject.

Macro—0.8m or 1m— ∞ : when you know in advance in which range your subject is. When the lens is set to either of these two modes, focusing time will be shorter. For close-up photography, set the focus range selector to Macro—0.8m, and for normal shooting set it to 1m— ∞ . If you set the focus range selector to the Macro—0.8m range, the lens will stop rotating when it reaches the 0.8m extremity and start to rotate in the opposite direction. Likewise, if the lens is set to the 1m— ∞ range it will not rotate beyond 1m.

- If you want to take a picture of a subject in the 0.8m—1m range, set the focus range selector to the Macro— ∞ range.

Macro Mechanism

This lens is equipped with a macro mechanism for low magnification close-up photography.

To set the lens for close-up photography, rotate the focusing ring into the macro range first, and then slide the focus range selector to the Macro—0.8m range. If you want to take a picture with maximum magnification and minimum field of view coverage in the macro range, set the AF mode to “MANUAL”, turn the focusing ring to the minimum focusing distance in the macro range and set the focal length to the telephoto end. Then gently press the shutter button halfway down to check the exposure and while looking through the viewfinder, move the camera (or your body) back and forth slowly until the image becomes clear.

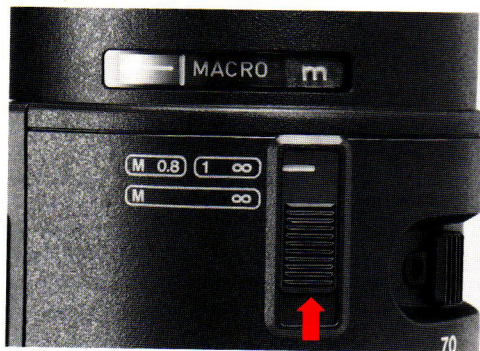

6. Manual Focusing



1) Slide the AF mode selector on the AC lens to "MANUAL".

- Manual focus should generally be used in the following cases:

- a) When using FD lenses or FL lenses.
- b) When using a linear polarization filter.



2) Turn the manual focusing ring and focus your subject using the cross-split prism.

The subject is in focus when the image is not fuzzy and the four quarters merge to become one unbroken image.

- It is not recommended to rely upon the focus tone to report correct focus when manually focusing. This is because it is not usually possible to stop motion immediately when the beeper sounds, so focus generally goes beyond the sharpest point.
- When focusing manually on a subject at infinity with AC lenses, the cross-split prism must be used to obtain accurate focus. (Simply turning the ring as far as it will go toward infinity will result in a blurred picture.)

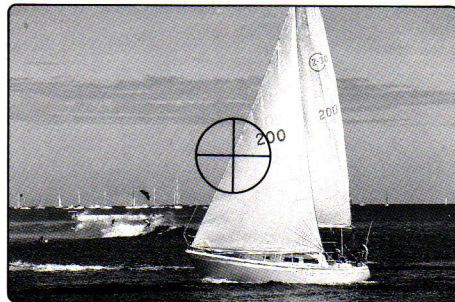
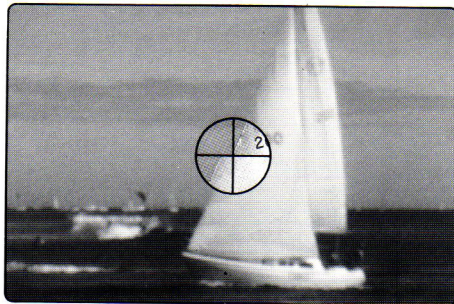

7. Shooting when your main subject is not centered (AF Lock Shooting)

If you compose the picture so that your main subject is not in the center, (as shown in the next page, illus. A), when using normal AF the background will end up being in focus and the subject will be out of focus. Use AF lock as follows in this case.

- 1) Slide the AF mode selector on the AC lens to "ONE SHOT".
- 2) Compose the picture so that your main subject is in the center (as shown in illus. B). Then gently press the shutter button halfway. The camera will find the point of focus and memorize the distance between you and the subject.
- 3) Recompose the picture as you like and without taking your finger off of the shutter button, press it all the way down.
 - The above shooting method is called AF lock shooting.
 - AF lock can also be used when shooting subjects difficult for autofocus. (See page 47.)

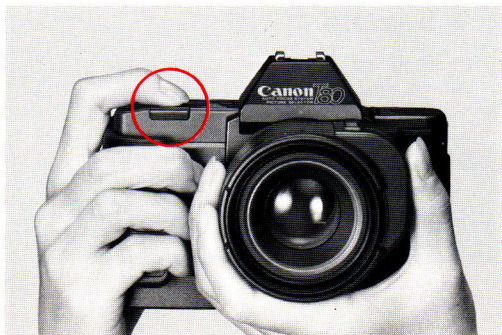

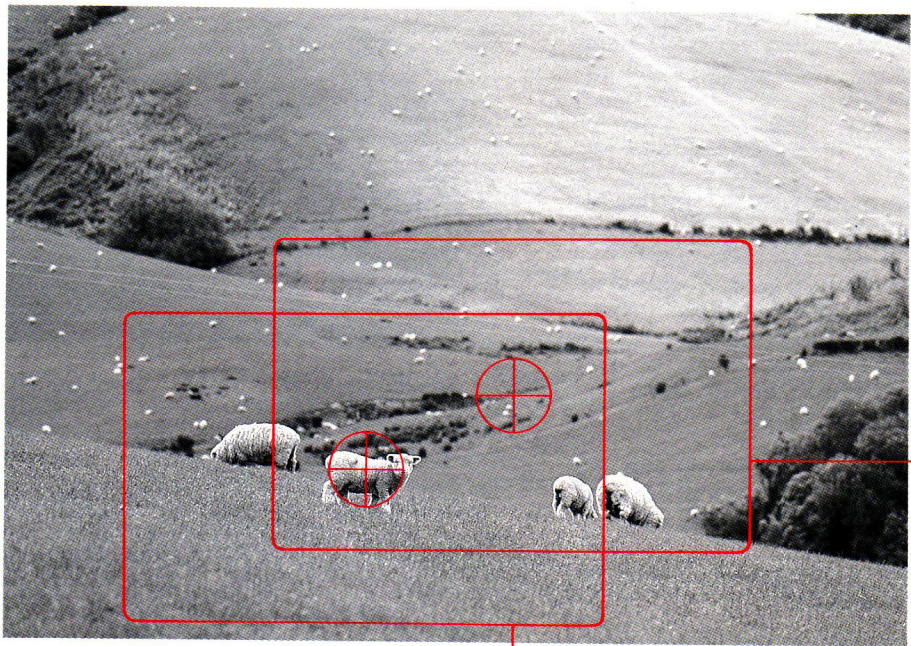

(A)

(B)

8. Difficult Subjects for Autofocus

The Canon T80 uses CCD line sensors to detect sharpness. This AF system is very accurate, but not perfect. The following subjects are difficult for autofocus:

Cross-split rangefinder AF coverage area

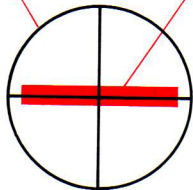

1) Subjects impossible to autofocus.

A. Subjects in low-light situations (a dark room, night scenes).



B. Low contrast subjects (misty scenes, light-colored or white objects).

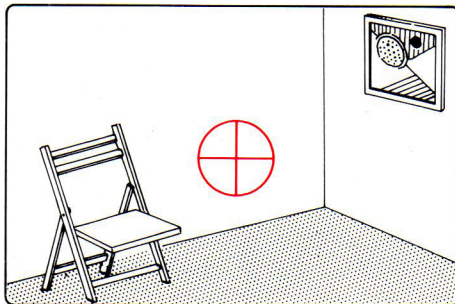

C. Subjects having generally horizontal patterns (window blinds).

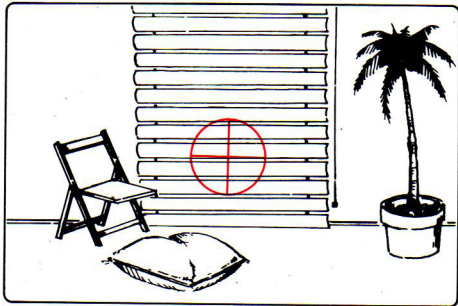

D. Subjects with strong reflections.

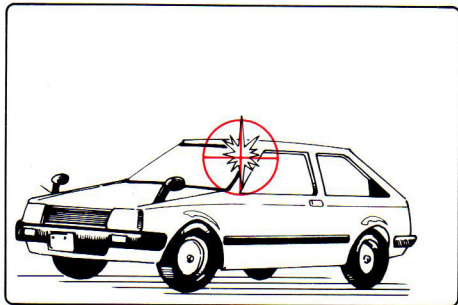

2) Subjects with which autofocus works incorrectly

A. Subjects with an object in front of them (zoo animals in a cage).

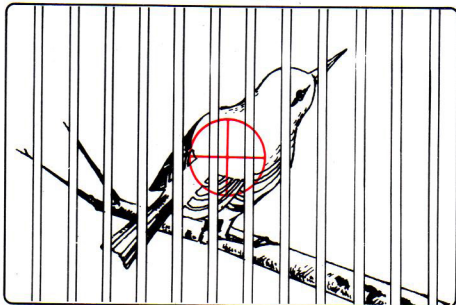

B. Moving subjects (that are difficult to keep within the AF coverage area).

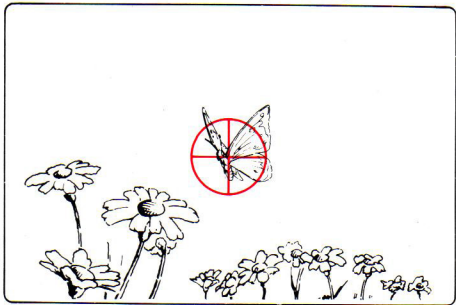

The above subjects can be focused as follows:

1. Autofocus a substitute subject at the same distance from the camera as your main subject, and then recompose the picture as you like (AF lock shooting).
2. Focus the subject manually using the cross-split prism.
3. Hold the camera vertically and focus the subject using autofocus, then recompose the picture as you like (AF lock shooting).

Focusing Tips

The T80's AF system works by judging subject contrast. It is therefore desirable to center the AF coverage area over the part of the subject with the highest contrast. For example, if your subject is a human face, the nose has more contrast than a cheek and an eye is even better than the nose. This is effective under bad shooting conditions such as in low-light situations.

In dark places where autofocus is not possible, one method is to autofocus the flame of a lighter or a match at the same distance as your subject. Then you can take your subject using a flash.

- When you are absorbed in shooting, you may occasionally take a picture without noticing that your main subject is not within the AF coverage area. We recommend checking the focus with your own eyes as well as the beeper.

9. Exposure Compensation

The T80's meter measures the entire viewing area, putting special emphasis on the central portion where the subject is most likely to be. But when there is a bright light, such as the sun or a bright window, behind your subject, the T80's meter may be over influenced by that light and your subject will come out too dark. In such cases, press the exposure compensation button while releasing the shutter. (The shutter speed is then automatically reduced 1-1/2 steps to increase exposure.)



10. Stopped-down AE Mode (“” mark)

It is necessary to use the stopped-down mode when using close-up accessories which have no FD signal pins, such as extension tubes, bellows, the Canon reflex lens or FL lenses.

The process for setting this mode is the same as that for other AE modes but manual focus is necessary. (See page 43.)



- Exposure warnings are the same as those listed on page 36.
- Lenses and accessories with FD signal pins cannot be set in this mode.
- AC lenses cannot be used with bellows or extension tubes.

11. Long Exposure (Bulb) Shooting

With non-AC lenses, it is possible to make an exposure longer than 2 seconds when doing such types of photography as astro or night photography.

1. Disengage the aperture ring from the “A” position and manually set an aperture.
2. While pressing the AE mode selector, operate the slide switch until the flowing mode appears on the LCD panel. Then operate only the slide switch to choose “B” (bulb).
3. The shutter will remain open as long as you press the shutter button.

- Bulb operation time is displayed on the frame counter of the display panel. Exposure time up to 60 seconds is possible.
- It is possible to control the exposure time within a range of 23 hours 59 minutes 59 seconds by using the Command Back 80 (optionally available).

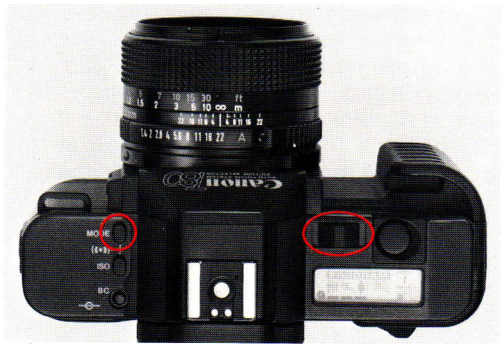

- Use of a tripod and the Remote Switch 60T3 is recommended when making long exposures. (See page 56.)
- AC lenses do not have an aperture ring so apertures cannot be set manually. It is therefore impossible to set the camera to bulb when an AC lens is mounted.

12. Flash Photography with Other Flash Units

When using Canon Speedlites, such as the A-series, 577G or 533G:

- 1) The shutter speed switches automatically to 1/90 sec.
- 2) Manually set the auto-flash aperture on the speedlite.
- 3) When the "P" and " 1/2 " marks light up in the viewfinder, the camera is ready for flash photography.

When using other makers' flashes

- 1) While pressing the AE mode selector, operate the slide switch until the flowing mode appears on the LCD panel. Then pick the 1/60 sec. shutter speed.
 - 2) Manually set the auto-flash f/stop on the lens and the flash.
 - 3) When the pilot lamp lights up, the camera is ready for flash photography.
- AC lenses cannot be used with other makers' flashes.

13. Remote Control Photography

When using remote control, attach the appropriate accessories directly to the remote control socket on the side of the camera body. The accessories are the Wireless Controller LC-1 and the Remote Switch 60T3. (See pages 56 and 58).

The Remote Switch 60T3 can be used when the camera is mounted on a tripod for close-up shooting or when using a telephoto lens with which camera-shake is a particular problem. With the optional Extension Cord 1000 T3 (approximately 10m or 30 ft. long), you can shoot from even further away.

Liquid Crystal Display

The T80's display panel uses liquid crystal to indicate exposure information. After about 5 years of normal use, the display may become hard to read.

The liquid crystal may respond relatively slowly in low temperatures and the display may become dark at high temperatures (about 60°C/140°F). Normal functioning will return when the temperature returns to normal.

Back-up Battery

If the camera is not used for a long time, you may want to remove the size AAA batteries for storage. In that case, a built-in lithium back-up battery powers the camera's memory of display items such as ISO value and frame counter number. Battery life is about 5 years. If, when the AAA batteries are replaced after prolonged storage, "ISO 100" starts to blink on the display panel, the back-up battery has run out and memory has been erased. In this case, reset the film speed. As long as AAA battery voltage is sufficient, normal camera operations are possible. If you remove the AAA batteries before the back-up battery is replaced, however, memory will be erased again. Please have the back-up battery replaced as soon as possible.

Take your camera to the nearest Canon Service facility for the replacement of the liquid crystal or the back-up battery. (Replacement will be at the owner's expense.)



14. Accessories

Canon Speedlite 277T



The 277T can be used as a fill-in flash for outdoor shooting as well as a normal flash when shooting at night or in a dimly lit room. For example, when you use the 277T to take a picture of a person backlit by the sun, your subject will not be too dark and the background will not be overexposed. 8 f/stops can be selected from f/2 to f/22 allowing you to consider the depth of field even in flash photography.

Remote Switch 60T3



The Remote Switch 60T3 is a cable release switch which is attached to the remote control socket of the camera body. When the remote switch release button is gently pressed halfway down, AF will operate and focus will be obtained. When the release button is pressed down all the way, the shutter will be released. For continuous shooting or long exposure (bulb) shooting, slide the release button to the running lock position.

Command Back 80



The Command Back 80 is an interchangeable camera back designed for exclusive use with the T80. As the name "Command" suggests, it not only records data but also controls the T80 for various types of timed photography.

The following operations are possible using the quartz controlled Command Back 80:

DATA FUNCTION

1. Printing of the auto date up through the year 2029 (automatic compensation for leap years and long and short months).
2. Printing of the Day/Hour/Minute in a 24 hour format.
3. Printing of an arbitrary 6-digit number plus the letters A through F.
4. Printing of a frame counter number up to 4 digits.

TIMER FUNCTION

1. Self-timer (the shutter is released after a fixed period of time).
2. Interval timer (the shutter is released at fixed intervals).
3. Long release timer (the shutter is released and held open for a fixed period of time when the T80 is set to "B" (This mode can only be used with non-AC lenses).
4. Frame counter setting (the camera stops automatically after the set number of exposures has been made).

- The timer settings can be set to any value from one second to 23 hours, 59 minutes, 59 seconds.
- It is possible to use both the data and timer functions at the same time.
- It is possible to program the camera completely by combining modes 1—4 in the timer function.

Wireless Controller LC-1



This accessory is a remote control photography device which uses infrared rays to control the camera from a distance. The LC-1 is particularly useful in such areas as sports photography, wildlife photography, and news coverage. The Wireless Controller LC-1 consists of a transmitter and a receiver. Use of the Remote Switch Adapter T3 is also required. Up to three cameras can be operated in series when the receivers are set to different channels.

- Autofocus cannot be used.

Lens Hood



We strongly recommend the use of a lens hood to keep out side light which may cause flare and ghost images to form on the image. Use only a hood which is specified for your particular lens. The AC 50mm f/1.8 and AC 35—70mm f/3.5—4.5 lenses use the BW-66 hood. Most Canon hoods fit into the bayonet mount and are fixed by turning.

Dioptric Adjustment Lenses S

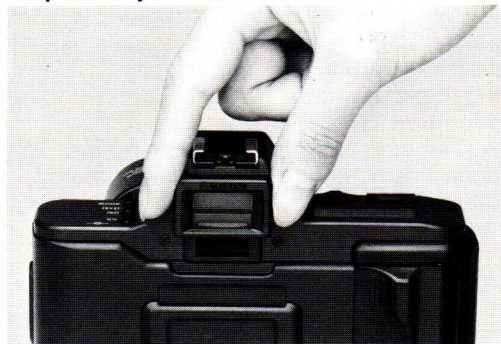

Ten eyesight correction lenses are available in powers of +3, +2, +1.5, +1, +0.5 0, -0.5, -2, -3 and -4 diopters. They may make viewing and focusing easier if you are near or farsighted. Slide the Eyecup T up to remove it before you attach the dioptic adjustment lens to the camera. Choose the one which is closest to your eyeglass prescription, and make a practical test if possible.

- Attaching the dioptic adjustment lens with the Eyecup T is not possible.

15. Caring for Your Camera

As with any precision instrument, proper care and maintenance involve a few simple rules in addition to common sense. Observing these few rules will keep your T80 in top condition at all times.

We recommend that you clean your T80 periodically using the tools listed below.

Cleaning tools: blower brush, cleaning fluid, cleaning tissue, silicone cloth.

- (1) To clean the lens surface and the viewfinder:

Blow off dust with the blower brush and then gently wipe the lens surface with a lens cleaning tissue which has been moistened with a few drops of lens cleaner.

- (2) To clean the reflecting mirror and the focusing screen:

Use only a blower brush. If more cleaning is necessary, NEVER attempt to do it yourself but take it to an authorized Canon service facility.

- (3) To clean the film chamber:

The film compartment also requires occasional cleaning with a blower brush to remove accumulated film dust particles which might scratch the film.

- (4) To clean the film pressure plate and the film guide rails:

Lightly wipe the surface with a cleaning tissue moistened with cleaning fluid.

PRECAUTIONS

- Be careful NEVER to touch the shutter curtain.
- After using the camera on a beach, clean it thoroughly. Salt and sand are your T80's worst enemies.
- Aerosol spray dust removers are not recommended for the shutter curtain area. If used, hold the can at least 20 cm (8 inches) away from the curtain.
- Film passing through X-ray examinations at airports, even when loaded in a camera, may be exposed and ruined. To avoid accidental exposure, tell the inspector you want your camera and film hand checked.

Storage of your T80

The best thing you can do for your T80 is to use it regularly. In the event that you must store it for quite a while, however, first remove it from its case or camera bag. Remove the batteries. Wrap the camera in a clean, soft cloth and place it in a cool, dry, dust-free place. If you store the body and lens separately, attach both the body and rear lens caps.

Avoid storing your T80 in the following places:

- “Hot Spots” such as the trunk, rear window shelf or glove compartment of a car.
- Laboratories or other such areas where chemicals may cause corrosion.
- In direct sunlight.

Before using the T80 after it has been stored for a long time or before using the camera for important events, carefully check the operation of each part.

Specifications

Type: 35mm single lens reflex (SLR), focal-plane shutter, fully automatic autofocus camera.

Format: 24 × 36mm

Usable lenses: Canon AC and FD lenses (full aperture metering) and Non-AC or FD lenses (stopped-down metering).

Lens mount: Canon mount

Viewfinder: Fixed eye-level pentaprism without condenser. Gives 92% vertical and 93% horizontal coverage of actual picture area and 0.83 × magnification at infinity with a standard 50mm lens.

Finder information: Displayed to the right of viewing area. 4-point LED:

- M (red) - Manual indicator (stopped-down, bulb, manual flash), flashes at 4Hz.
- P (green) - AE (program) indicator, when shining steadily. Flashes for camera-shake, over/underexposure warnings.
1/90—1/30 sec, flashes at 1Hz.
1/30—2 sec, flashes at 2Hz.
Over/underexposure, flashes at 8Hz.
- ◇ (red) - Mode warning indicator, shines steadily.

- ⚡ (green) - Flash charge completion indicator, shines steadily.

Light metering system: Through-the-lens (TTL) full aperture (for AC and FD lenses), using silicon photocell (SPC), center-weighted average metering.

AE control system:

- Multiprogram AE using the picture selector system
 - (1) Standard program
 - (2) Deep focus (deep depth of field)
 - (3) Stop action (stop subject motion)
 - (4) Shallow focus (shallow depth of field)
 - (5) Flowing (shutter speeds of 1/15, 1/30, 1/60, 1/125 sec.)
- Manual
- Stopped-down AE (only for lenses without FD signal pins)

Meter coupling range: With ISO 100 film and a 50mm f/1.4 lens: EV1—19.

Film speed: ISO 12 — ISO 1600 (in 1/3 steps). Displayed on the LCD panel when pressing the ISO button.

Exposure compensation: Correction of +1.5 step by pressing exposure compensation button.

AF system:

- Type:
TTL sharpness detection system using CCD elements.
- AF operation:
Activated by pressing shutter button halfway down when using AC lenses.
- AF modes:
One shot, Servo, manual
(During continuous shooting in Servo, the camera maintains the original focus for all the shots even if the subject distance changes.)
- AF focus signal:
Electronic beeper tone. Can be turned OFF by simultaneously pressing film speed setting button and AE mode selector.
- AF ranging brightness range:
EV4—18 when using the AC 50 mm f/1.8 lens, EV5—19 when using the AC 35—70 mm f/3.5—4.5 and the AC 75—200 mm f/4.5 (ISO 100).

Shutter speeds: Automatic: 1/1000 sec—2 sec.
Manual: 1/60 sec and Bulb.
X-sync: 1/90 sec.

Self-timer: Electronically controlled, with a delay of approx. 10 sec.

Film loading and first frame positioning: Automatic. After the film has been positioned and the back cover closed, the film is automatically advanced to the 1st usable frame and then automatically stopped. Three blank frames are advanced. The frame counter display then reads "1".

Film wind: Automatic using built-in motor, enabling continuous shooting. Confirmation by floating bar marks on LCD panel. When the end of the film is reached, the film-load indicator and the frame counter number on the LCD panel start blinking. A beeping sound is also emitted.

Film rewind: Automatic using built-in motor. Automatic stop after film has been rewound into the cartridge. Rewind completion is indicated on LCD panel.

Power source: Main power source: Four AAA size batteries. Alkaline batteries are standard but carbon-zinc may also be used. Memory back-up: Built-in lithium battery (BR-1225 or CR-1220), battery life is approx. 5 years.

Battery check: By pressing the battery check (BC) button. Three energy levels are shown by bar marks on the LCD.

Flash contact: Coupled directly to the camera by means of the X-contact on the accessory shoe.

Automatic flash:

1. Program flash AE: With the Speedlite 277T or 244T. After sending out an infrared pre-flash to judge the distance and the reflectivity of the subject, the 277T or 244T sets the aperture and 1/90 sec shutter speed automatically. When out of shooting distance range (too far away), a warning is given, indicated by the "P" flashing in the viewfinder.

2. Electronic flash AE: With the 277T in "F.NO.SET" mode, or with other Canon Speedlites, shutter speed is set automatically to X-sync and aperture to the f/stop that has been set on the flash.

Remote control: Possible. With three-terminal contact for remote control. Remote Switch 60T3 is required.

Back cover: Removable, with memo holder. Opened by sliding latch with safety lock.

Dimensions: 141 (W) × 102 (H) × 54.7 (D) mm
(5-9/16" × 4" × 2-1/8")

Weight: 555 g (19—9/16 oz) body only.

Subject to change without notice.

	AC 50mm f/1.8	AC 35—70mm f/3.5—4.5
Format	24 × 36mm	
Focal Length	50mm	35—70mm
Maximum Aperture	f/1.8	f/3.5—4.5 (Varies according to the focal length)
Lens Construction	6 elements in 4 groups.	9 elements in 8 groups.
Angle of View:		
Horizontal	40°	54°—29°
Vertical	27°	38°—19°30'
Diagonal	46°	63°—34°
Focusing Mechanism	Automatic or manual. Straight helicoid type.	Automatic or manual. Rotation of front lens group.
Automatic Focusing Range	0.6—∞ (m)	MACRO 0.5—∞ (m) Focus range selector: Three settings; Macro—∞, Macro—0.8m and 1m—∞.
Zooming	—	Rotation of zooming lever
Zooming Scale	—	35 50 70 (All dark yellow)
Macro Mechanism	—	Helical front group movement, full range macro. (Closest focusing distance in macro range is 39cm from the film plane.)
Macro Magnification		35mm—0.11X (218 × 327mm) 70mm—0.2X (120 × 180mm)
Mount	Canon mount	
Filter Diameter	52mm	
Hood	BW-66	
Dimensions	74.2W × 66H × 47.5D mm (2-15/16" × 2-5/8" × 1-7/8")	76W × 68H × 68D mm (3" × 2-11/16" × 2-11/16")
Weight	210g (7-7/16 ozs)	285g (10-1/16 ozs)

Subject to change without notice.





Canon

CANON INC. 7-1, Nishi-Shinjuku 2-Chome, Shinjuku-ku, Tokyo 160, Japan
Mailing address: P.O. Box 5050, Dai-ichi Seimei Building, Tokyo 160, Japan

U.S.A. _____ **CANON U.S.A., INC. HEADQUARTERS**
One Canon Plaza, Lake Success, N.Y. 11042, U.S.A.
CANON U.S.A., INC. MANHATTAN SERVICE CENTER
600 Third Avenue, New York, N.Y. 10016, U.S.A.
CANON U.S.A., INC. ATLANTA BRANCH
6380 Peachtree Industrial Blvd., Norcross, Georgia 30071, U.S.A.
CANON U.S.A., INC. CHICAGO BRANCH
140 Industrial Drive, Elmhurst, Illinois 60126, U.S.A.
CANON U.S.A., INC. LOS ANGELES BRANCH
123 Paulerino Avenue East, Costa Mesa, California 92626, U.S.A.
CANON U.S.A., INC. LOS ANGELES SERVICE CENTER
3321 Wilshire Blvd., Los Angeles, California 90010, U.S.A.
CANON U.S.A., INC. SANTA CLARA BRANCH
4000 Burton Drive, Santa Clara, California 95054, U.S.A.
CANON U.S.A., INC. DALLAS OFFICE
3200, Regent Blvd., Irving, Texas 75063-3145, U.S.A.
CANON U.S.A., INC. HONOLULU OFFICE
Bldg. 9-2, 1050 Ala Moana Blvd., Honolulu, Hawaii 96814, U.S.A.

CANADA _____ **CANON CANADA INC. HEADQUARTERS**
6390 Dixie Road, Mississauga, Ontario L5T 1P7, Canada
CANON CANADA INC. MONTREAL SERVICE CENTRE
10652 Côte de Liesse, Lachine, Quebec H8T 1A5, Canada
CANON CANADA INC. CALGARY OFFICE
2828, 15th Street, N.E. Calgary, Alberta T2E 7K7, Canada

EUROPE, AFRICA
& MIDDLE EAST _____ **CANON EUROPA N.V.**
P.O. Box 7907, 1008 AC Amsterdam, The Netherlands
CANON FRANCE-PHOTO CINEMA S.A.
30, boulevard Vital-Bouhot, Ile de la Jatte, 92521 Neuilly-sur-Seine, France
CANON UK LTD.
Units 4 & 5, Brent Trading Centre, North Circular Road, London NW10 0JF, United Kingdom
CANON EURO-PHOTO G.m.b.H
Linsellesstraße 142-156, D-4156 Willich 3, West Germany

CENTRAL &
SOUTH AMERICA _____ **CANON LATIN AMERICA, INC. DEPTO. DE VENTAS**
Apartado 7022, Panamá 5, República de Panamá
CANON LATIN AMERICA, INC. CENTRO DE SERVICIO Y REPARACION
Apartado 2019, Zona Libre de Colón, República de Panamá

SOUTHEAST ASIA _____ **CANON HONG KONG TRADING CO., LTD.**
Golden Bear Industrial Centre, 7/F, 66-82 Chai Wan Kok Street,
Tsuen Wan, New Territories, Hong Kong
CANON SINGAPORE PTE. LTD.
95 South Bridge Road #13-01/15, South Bridge Centre, Singapore 0105

OCEANIA _____ **CANON AUSTRALIA PTY. LTD.**
Unit 1/37, Waterloo Road, North Ryde (Macquarie Park), N.S.W. 2113, Australia

JAPAN _____ **CANON SALES CO., INC.**
11-28, Mita, 3-Chome, Minato-ku, Tokyo 108, Japan

PUB. C-IE-114C
0985N12

©CANON INC. 1985
CY8-6015-002

PRINTED IN JAPAN