

# WILSONWERKS ARCHIVES

This camera manual is for reference and historical purposes, all rights reserved.

This cover page is copyrighted material. This document may not be sold or distributed without the express consent of the publisher.

©2008-2025 wilsonwerks Llc

# Honeywell Photographic Processing Equipment



**Honeywell**

**Nikor...for 39 years the choice  
of the professionals.**

## New Honeywell Sable 1

Honeywell's amazing new Sable 1 incorporates color enlarging, color and exposure analyzing and precision timing all in a single machine. That means color printing no longer has to be a complicated, time-consuming process. And the Sable 1 is great for black-and-white printing, too.

The Sable 1 enlarger features a unique lamp housing that makes maximum use of the light source providing even illumination and minimal heat build-up. A special "hot mirror" and concentric radiator vanes atop the unit dispel the small amount of heat from the 50-watt halogen lamp. Your negatives are always safe in the Sable 1.

Color-coded controls are conveniently placed for fast, efficient operation. And everything works automatically! Directions below for using the Sable 1 include seven easy steps to perfect color prints.

1. Insert negative and pull out diffusion filter.
2. **Red Analysis** — Push red button. Set red timer and lens aperture to "N". Depress yellow button while raising enlarger head until indicator goes off.
3. **Green Analysis** — Push green button. Depress yellow button while slowly stopping lens down until indicator light goes off. Set green timer at letter indicated.
4. **Blue Analysis** — Push blue button. Depress yellow button while slowly stopping lens down until indicator light goes off. Set blue timer at letter indicated.
5. **Compose** — Push diffusion filter back. Compose and focus picture on enlarging easel.
6. **Exposure Analysis** — Push white button. Place exposure probe in shadow area of picture. Depress yellow button while slowly stopping lens down until indicator light goes off.
7. **Expose Print** — Turn off lights. Insert color paper. Click enlarger switch forward to start exposure. When the enlarger shuts off, your paper is ready.

Negative Size: 35mm full frame (24x35mm). Accessory carriers for half-frame 35mm and 126 sizes.

Magnification Range: 2½ to 15x.

Lens: 50mm f/2.8. Fully color corrected.

Enlarging Lamp: 50-watt, 8-volt quartz halogen.

Line Input: 117-volts, 60hz. nominal, appx. 150 watts. Internal stabilization against normal line voltage variations.

Base Dimensions: 16 x 26½.

Height: 43½" to top of column; 49" maximum.

Weight: 65 lbs., appx.

Cat. No. 5071 . . . . . \$599.50

Major working parts:

- A. Enlarger Head
- B. Focusing Ring
- C. Height Adjustment Knob
- D. Calibrated Aperture Scale
- E. Filter Bank
- F. Room and Safelight Outlets
- G. Exposure Probe
- H. Indicator Light
- I. Color-Coded Analyzer Buttons
- J. Yellow Read Button
- K. Red Timer
- L. Green Timer
- M. Blue Timer
- N. Focus/Start Switch
- O. B/W—Color Selector Switch
- P. Color Analysis Sensors
- Q. Calibration Adjustments
- R. Negative Carrier

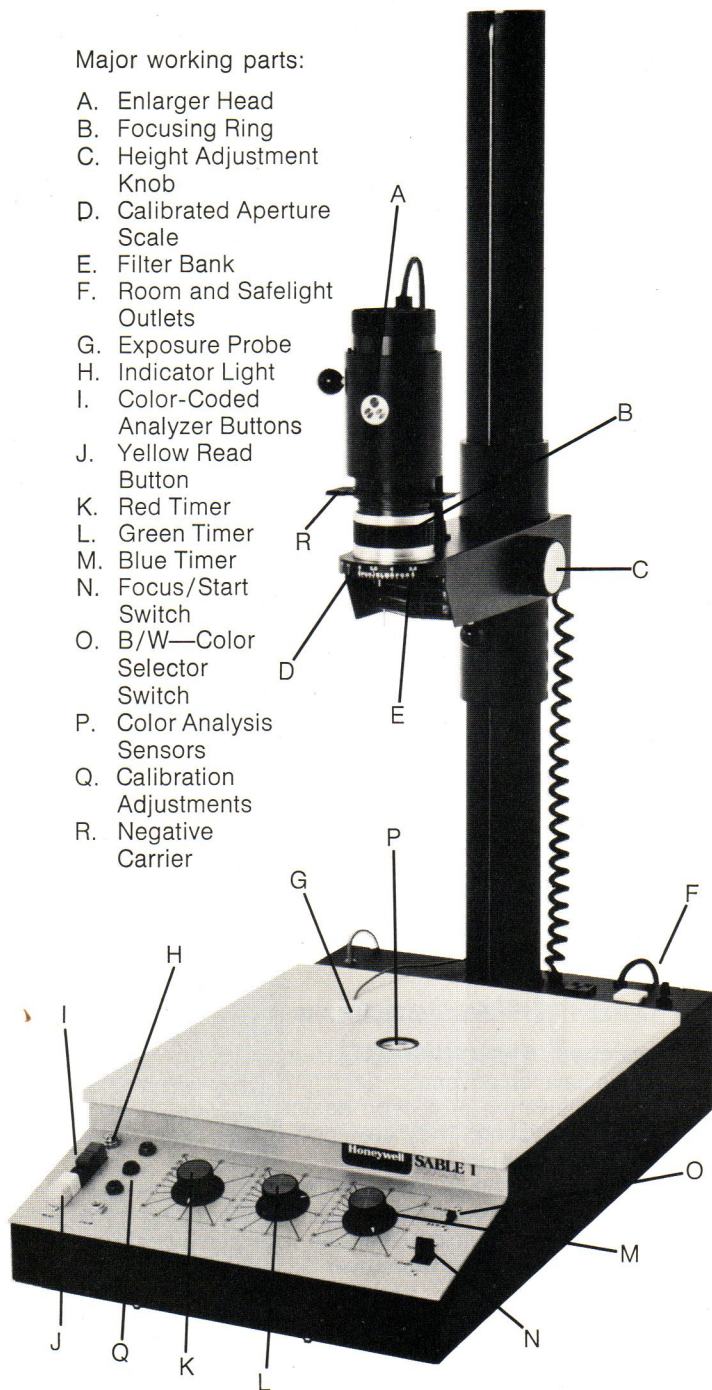

## You've got a lot going for you— with Honeywell Nikor

The Honeywell Nikor products listed within these pages are designed to meet virtually any of today's darkroom needs.

There are complete processing outfits, reels, tanks, safety trimmers with edgelites, loading stands, drying equipment, loading chutes, Roto-Wash tanks, and many specialized items.

### Nearly four decades of quality

And every piece of Honeywell Nikor equipment is backed by our 39-year record—for making the kind of film processing equipment demanded by no-nonsense professionals, accomplished amateurs, and bright beginners.

We don't scrimp on time or materials. And we continue to search for ways to improve products our customers have told us were already the best on the market. An example: the new professional tanks.

### Lifetime guarantee

Honeywell Nikor reels and tanks are guaranteed for the life of the original retail purchaser, under normal use.

Premium grade stainless steel is used in the manufacture of our reels and tanks. Welds are satin-smooth. Hand-finished surfaces are non-corrosive and resist today's modern chemicals.

If you have any questions about Nikor products, visit your nearest Honeywell photo dealer. He'll be happy to help you select equipment to fit any and all of your photo processing needs.

## Honeywell Nikor Professional Tanks

### Quick Fill Professional Tanks

Honeywell's new Nikor professional film developing tanks have an advanced-design multi-baffled lid that gives maximum protection against visible light, UV, and IR radiation. They are specially recommended for all high speed films.

In addition to new multi-baffled design, these new professional tanks have a wider mouth so they are easier to use, quicker to fill. As liquid rushes in, air escapes, permitting more even fill, better distribution of developer.

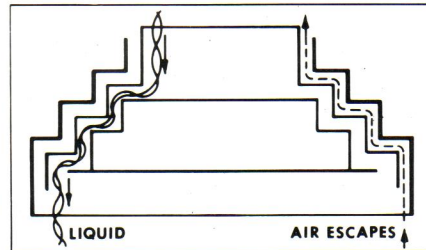

Hand-polished, super-hardened stainless steel resists corrosion, cleans easily. Tanks are tough and well-built; lids are precision fit and keep a precision fit through long use. Thermal properties of Nikor tanks allow precise control over critical processing temperatures.

Honeywell Nikor tanks were used to develop the irreplaceable Apollo moon pictures — and have been the choice of professionals and amateurs alike for critical processing for nearly four decades.

### Cat. No.

3032	Pro Q08 Small Format Tank . . . . .	\$ 8.95
3033	Pro Q15 Medium Format Tank . . . . .	14.95
3034	Pro Q30 Multiple Standard Tank . . . . .	19.95
3035	Pro Q60 Multiple 12½" Tank . . . . .	28.95
3036	Pro Q90 Multiple 17" Tank . . . . .	34.95
3037	Pro Q120 Multiple 22" Tank . . . . .	37.95

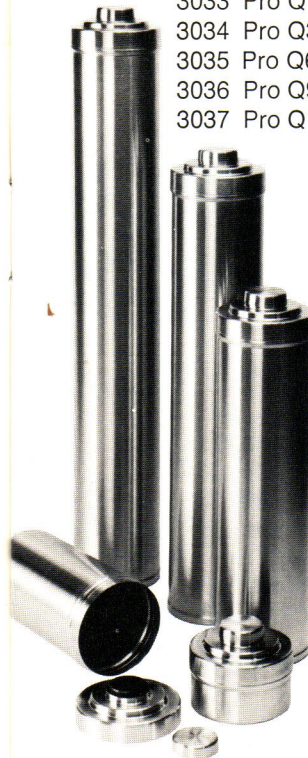

## Honeywell Nikor Developing Tanks

Choose from Quick-Fill or Plain — they're all designed to adjust rapidly to and maintain critical developing temperatures.

Quick-Fill is the exclusive feature that offers you the fastest filling in the world (6 seconds for a 15 oz. tank!).

## Quick-Fill

### Cat. No.

3020	8 oz. Small Format Tank . . . . .	\$ 7.95
3021	15 oz. Medium Format Tank . . . . .	\$11.95
3022	18 oz. Miniature Cut Film Tank . . . . .	\$14.95
3023*	25 oz. Extra Film Length Tank . . . . .	\$17.95
3024	30 oz. Multiple Standard Tank . . . . .	\$14.95
3025*	50 oz. Extra Film Length Tank . . . . .	\$19.95
3026	60 oz. Multiple 12½" Tank . . . . .	\$24.95
3027	90 oz. Multiple 17" Tank . . . . .	\$29.95
3028	120 oz. Multiple 22" Tank . . . . .	\$33.95

## Plain

### Cat. No.

3049*	50 oz. Extra Film Length Tank . . . . .	\$14.95
3052	60 oz. Multiple 12½" Tank . . . . .	\$17.95
3053	90 oz. Multiple 17" Tank . . . . .	\$20.95
3055*	110 oz. Extra Film Length Tank . . . . .	\$18.95
3051	52 oz. 70/89mm-100" Tank . . . . .	\$19.95
3056	120 oz. Multiple 22" Tank . . . . .	\$24.95

\*Denotes larger diameter (4½") tank to hold larger diameter reels for 220 and 35mm 6-foot film length.

## Honeywell Nikor Developing Outfits

- Stainless Steel
- Quick-Fill
- Lifetime Warranty

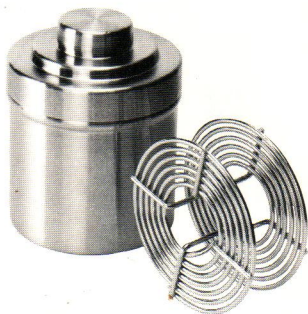

### Cat. No.

3000	35mm Single Outfit . . . . .	\$12.90
	One—8 oz. Small Format Tank	
	One—35mm/36 exp. Reel	
3001	35mm Double Outfit . . . . .	\$21.85
	One—15 oz. Medium Format Tank	
	Two—35mm/36 exp. Reels	
3002	120/620 Single Outfit . . . . .	\$16.90
	One—15 oz. Medium Format Tank	
	One—120/620 Reel	
3003	220 Double Outfit . . . . .	\$31.85
	One—50 oz. Extra Film Length Tank	
	Two—220 Reels	

## Honeywell Nikor Developing Reels and Miniature Cut Film Kit

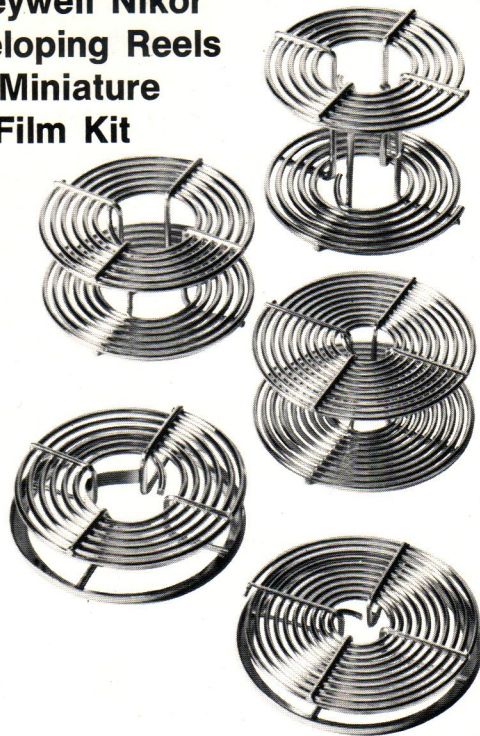

Superior construction is your assurance these reels will fit smoothly into any Honeywell Nikor tank of the same size—at any temperature.

### Cat. No.

3070	Minox Film Reel (use one or two reels with Quick-Fill 8 oz. tank) . . . . .	\$ 4.95
3071	16mm 39" Film Reel (use one or two reels with Quick-Fill 8 oz. tank) . . . . .	\$ 4.95
3072	35mm 20 exp. Film Reel . . . . .	\$ 4.95
3073	35mm 36 exp. Film Reel . . . . .	\$ 4.95
3074	35mm 6' Film Reel . . . . .	\$ 5.95
3075	116/616 Film Reel . . . . .	\$ 4.95
3077	120/620 Film Reel . . . . .	\$ 4.95
3078	122 Film Reel . . . . .	\$ 4.95
3079	126 Instamatic* Film Reel . . . . .	\$ 4.95
3080	127 Film Reel . . . . .	\$ 4.95
3081	220 Film Reel . . . . .	\$ 5.95
3082	Miniature Cut Film Kit (for 2¼ x 3¼ cut film, holds 12 sheets) . . . . .	\$ 6.95
3084	70mm 100" Reel . . . . .	\$12.95
3085	89mm 100" Reel (3½" film width) . . . . .	\$12.95

\*Trademark—Eastman Kodak Company.

# Maximum Reel Capacity Honeywell Nikor Tanks

## REEL DESIGNATION AND CATALOG NUMBER

REEL		3070	3071	3072	3073	3074	3075
Tank Cat. No.	Type and Capacity (Oz.)	9.5mm Minox	16mm	35mm-20x	35mm-36x	35mm 6'	116/616 (70mm)
3020 3032	Q08	2	2	1	1		
3021 3033	Q15	5	3	2	2		1
3022	Q18	6	4	2	2		1
3023	*Q25					2	
3024 3034	Q30	10	7	4	4		2
3025	*Q50					3	
3026 3035	Q60	22	14	8	8		4
3027 3036	Q90	30	19	11	11		6
3028 3037	Q120	40	24	14	14		7
3049	*P50					4	
3051	P52						
3052	P60	21	14	8	8		4
3053	P90	29	19	11	11		6
3055	*P110					8	
3056	P120	39	24	14	14		7
3131	Std. Cage	90	54	30	30		12
3132	Lge. Cage					10	

\*Tank Diameter 4½"      Q = Quick-Fill

3077	3078	3079	3080	3081	3082	3084	3085
120/620	122	Inst. 126	127	220	Min. Cut Film Kit	70mm-100"	89mm-100"
		1					
1		2	1				
1	1	2	1		1		
				1			
2	1	4	3		1		
				2			
5	2	8	6				
7	3	11	8				
9	4	14	11				
				2			
						1	1
5	2	8	6				
7	3	11	8				
				4			
9	4	14	11				
18	12	30	24				
				6			

P = Plain (refer to page 7)

## Accessories for Honeywell Nikor Tanks and Reels

### Honeywell Nikor 35mm Cassette Opener

Made in the well-known Nikor tradition of quality and durability, the Honeywell Nikor Cassette Opener is designed to quickly pop open both the reusable and crimped-end type of 35mm cassettes. Made of sturdy metal, it has an easy spring action. A handy addition to your darkroom equipment!

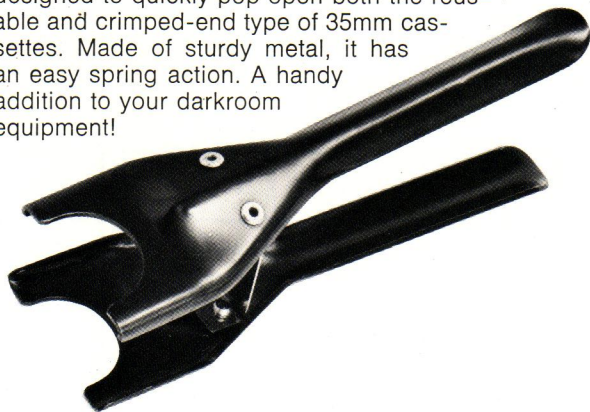

**Semi-Automatic Loader—**  
stainless steel



### Replacement Tank Cover Cap—

fits all Quick-Fill Covers  
(except new  
professional  
type)

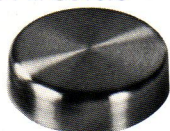

**Lift Rod—**for easier loading and  
unloading of Multiple-Reel Tanks

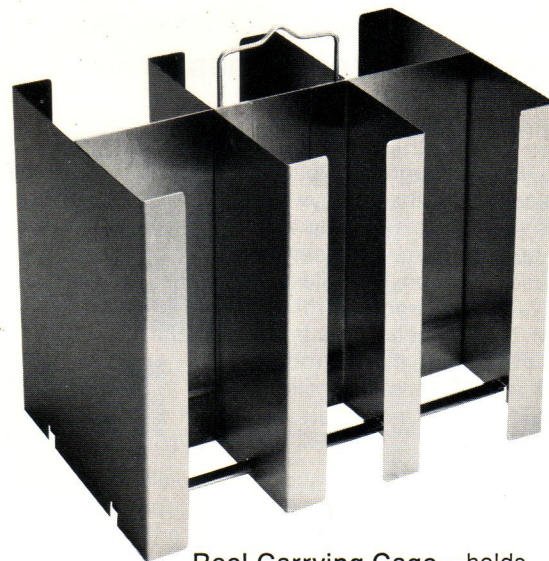
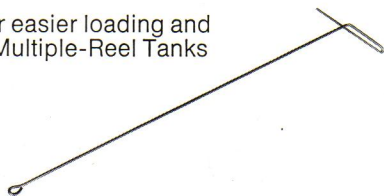

**Reel Carrying Cage—**holds  
up to 36 35mm-20 exp. reels.

### Cat. No.

3137	Cassette Opener . . . . .	\$ 1.25
3120	Semi-Automatic Loader (35mm 36 exp. Reels Cat. No. 3073)	\$ 2.95
3121	Semi-Automatic Loader . . . . .	\$ 2.95
	(120/620 Reels Cat. No. 3077)	
3123	Cap, only . . . . .	\$ .85
	for Quick-Fill Covers	
3136	Lift Rod, 4" . . . . .	\$ 1.00
	(70mm/89mm 100" Tank)	
3124	Lift Rod, 6½" . . . . .	\$ 1.00
	(Multiple Standard Tank)	
3125	Lift Rod (12½" Tank) . . . . .	\$ 1.00
3126	Lift Rod (17" Tank) . . . . .	\$ 1.00
3127	Lift Rod (22" Tank) . . . . .	\$ 1.00
3128	Film Washing Unit (12½" Tank) . . .	\$10.50
3129	Film Washing Unit (17" Tank) . . .	\$10.50
3130	Film Washing Unit (22" Tank) . . .	\$10.50
3131	Reel Carrying Cage . . . . .	\$35.95
	(Std. ¾" Diameter Reels)	
3132	Reel Carrying Cage . . . . .	\$39.95
	(Large 1½" Diameter Reels)	

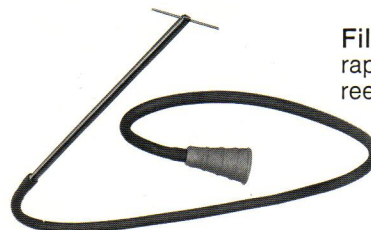

**Film Washer Unit—**for  
rapid thorough wash with  
reels and tanks.

## Honeywell/Wein Darkroom Accessories

### Honeywell/Wein Magnetic Mixer

Mix your darkroom solutions efficiently and automatically with the Honeywell/Wein Magnetic Mixer. This stainless steel mixer activates the solution from the bottom to prevent "settling" and to reduce oxidation. It's solid-state, featuring variable speed control from 0-3000 RPM. The Magnetic Mixer is free of shafts and metal parts that corrode or contaminate solutions. Two gallon capacity. (Beaker not included.)



Cat. No. 2347 ..... \$49.95

### Honeywell/Wein pH Meter



Chemical consistency of darkroom solutions is crucial to making high quality negatives and prints. The Honeywell/Wein pH Meter's simple design, easy operation and accuracy makes it the ideal tool for exacting pH measurement and control. It features two scales: a normal 0-14 pH, accurate to .2 pH and an expanded scale accurate to .08

pH. A single electrode probe allows ultra-fast response to pH reading. Powered by a 9 Volt transistor battery.

Cat. No. 2345 ..... \$129.95

### Honeywell/Wein Timer T60

Perfect printing depends on perfect timing. The electronic Honeywell/Wein Timer T60 offers accuracy and reliability for enlarging at an unbelievably low price. This solid-state unit features a highly sensitive "touch start" control to avoid vibration which can cause unsharp pictures. Time range: 0-60 seconds. It offers 300 Watt enlarger lamp capacity and a Safelight outlet with a 25 Watt capacity.



Cat. No. 2330 ..... \$49.95

### "Touch Start" Electronic Timer T120

This versatile timer has the same outstanding features as the T60, plus two time ranges: 0-24 seconds and 0-120 seconds. It offers a 1000 Watt enlarger lamp capacity and a Safelight outlet with a 100 Watt capacity. Accurate to within 2% of setting on dial.

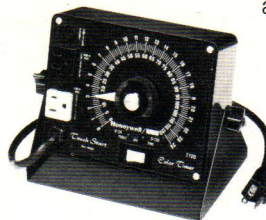

Cat. No. 2331 ..... \$119.95

### Honeywell/Wein Micronome

Save time by doing your dodging, burning-in, and overall exposures all at once. The miniature, solid-state Honeywell/Wein Micronome is an ideal accessory timer that audibly ticks away each second to within 1/4 of a second accuracy. Used with the "Touch Start" timer, the Micronome allows you to count seconds within the overall exposure for consistent dodging-burning. May be used as an enlarger timer alone, too. Plugs into any AC outlet.



Cat. No. 2335 ..... \$14.95

### Honeywell/Wein Regulites WP250 and WP650



Fluctuating light output makes a big difference in the quality of your prints. These solid-state, automatic voltage stabilizers are designed to insure constant light output of incandescent lamps, in spite of voltage changes. Both Regulites give instantaneous and heatless operation, maintaining 118 volts DC  $\pm$  1% accuracy RMS. For use with incandescent lamps only.

Cat. No.

2340 Regulite WP250 (250 W capacity) ..... \$54.95

2341 Regulite WP650 (650 W capacity) ..... \$69.95



# Honeywell Nikor Enlarging Easel

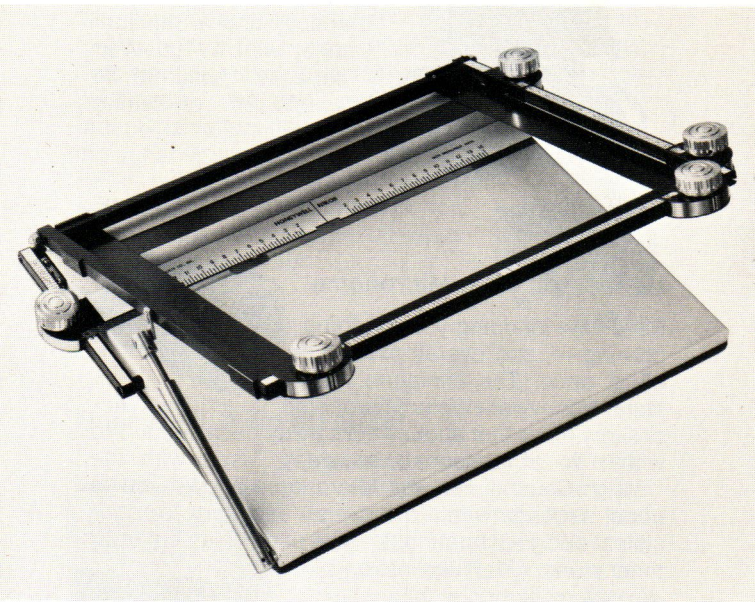

Now, you can speed up your enlarging with the new Honeywell Nikor Enlarging Easel! Fast-handling. Precise. And simple to operate. Every component of this precision easel is built to last. And it's from Nikor . . . a name you know you can depend on!

## A Few Outstanding Features:

- Paper size—adjustable from 2" x 3" to 11" x 14".
- Picture size—adjustable from 2" x 2" to 11" x 14".
- Paper remains centered on baseboard, no matter what size, thus allowing the easel to remain centered under the enlarger.
- Frame is variably positioned by spring-loaded frame support.
- Independently variable borders—allowing artistic cropping on baseboard.

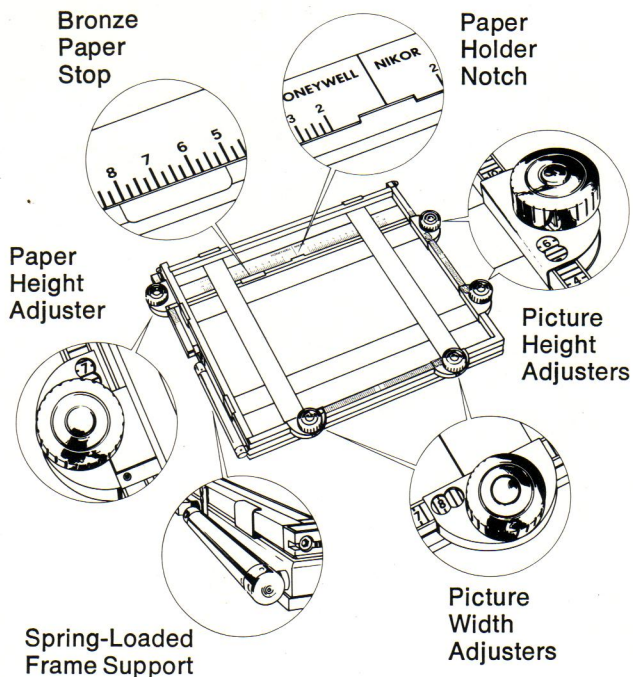

## Operation . . . simple and precise!

- Non-skid, safe-yellow baseboard—eliminates emulsion-fogging reflections.
- Standard auto-focus-height base—1".
- Heavy-duty, durable, all metal construction.
- Easy-to-read position indicators.
- Two-way, right or left side, paper alignment.
- Four teflon coated stainless steel bands, positively positioned by spring-loaded, gear-driven knobs—bands cannot be accidentally bumped out of position.

Cat. No. 3150 . . . . . \$69.50

## Honeywell Nikor Safety Trimmers

For unparalleled precision and reliability

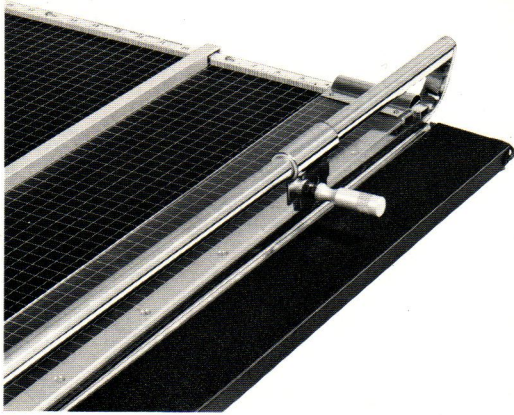

Honeywell Nikor Safety Trimmers have few, if any, equals when it comes to cutting paper and other materials dependably and accurately—with no fuzzy edges. And each Honeywell Nikor Safety Trimmer offers a host of features:

- Absolutely safe cutting wheel and blade combination that slices—but doesn't chop.
- Solid aluminum cutting board with an anodized surface harder than sapphire.
- Engraved permanent 1/2" spaced grid lines in the cutting board.
- Nickel-plated, maximum durability cutting wheel and guide bar.
- Non-lube nylon bearings for smooth operation.
- Extruded aluminum scale bar that won't allow the paper to slip under it.
- Scale bar is movable so it can be aligned and squared with the cutting edge and the cutter board grid lines.
- Cuts tissue, paper, cardboard, film, plastic, etc.

And because the cutting wheel moves beyond the cutting surface and up and out of the cutting path, incomplete cuts are eliminated and the repositioning of material is easier.

### Cat. No.

3216	12" Trimmer	. . . . .	\$41.95
3217	16" Trimmer	. . . . .	\$59.95
3218	20" Trimmer	. . . . .	\$79.95
3219	24" Trimmer	. . . . .	\$99.95

## Honeywell Nikor Safety Trimmer Accessories

- **Safety Trimmer Edgelites**—illuminate the cutting edge and eliminate guesswork in precise trimming.
- **Adjustable Guide Bars**—for accurate long-run trimming—such as 8x10 quantity glossies.
- **Hold-downs**—Durable, Lucite shields that adjust to material thickness and firmly hold soft or extra thin materials.

### Cat. No.

3220	12" Hold-Down	. . . . .	\$13.95
3221	16" Hold-Down	. . . . .	\$14.95
3222	20" Hold-Down	. . . . .	\$16.95
3223	24" Hold-Down	. . . . .	\$18.95
3224	12" Guide Bar	. . . . .	\$ 3.95
3225	16" Guide Bar	. . . . .	\$ 4.50
3226	20" Guide Bar	. . . . .	\$ 4.95
3227	24" Guide Bar	. . . . .	\$ 5.50
3212	12" Edgelite	. . . . .	\$16.95
3213	16" Edgelite	. . . . .	\$19.95
3214	20" Edgelite	. . . . .	\$24.95
3215	24" Edgelite	. . . . .	\$29.95

## Honeywell Nikor Film Processing Equipment

Rapid, controlled processing for advanced amateurs and professionals.

On the following pages you can select from more than 80 different stainless steel tanks, reels and other equipment for use in processing long lengths of film. No matter which equipment you choose, you'll discover you'll be able to shorten your darkroom time—and produce desired results with maximum economy of expensive developing chemicals.

You'll also discover that Honeywell Nikor's open-reel construction permits processing solutions to flow freely for uniform development and later, to permit complete flashing of color or black and white reversal films. Once the reel is loaded, the film stays in the reel until it is dry and ready for viewing.

A chart on page 20 classifies each item according to size or gauge of film, and the maximum length of film that can be processed.

**Special sizes:** Reels and machines for film sizes not listed can be obtained on special order through your Honeywell dealer—at prices 15% over the price of the next larger standard size. Tanks made of Red Brass can also be special-ordered.

### Film Processing Outfits

Film Processing outfits should be tailored to the particular process to be used; black and white, color negative or color reversal. Most black and white processes can be handled in three tanks plus a roto-wash tank. Color systems usually require five or seven tanks, plus several roto-wash tanks (a single roto-wash tank may be used but it must be drained and thoroughly rinsed between wash steps).

An outfit is generally considered to be a three-tank system, consisting of a rapid-loading, precision-welded stainless steel film reel, a lightweight loading stand, a loading chute, a set of 3 easy-to-store nesting stainless steel tanks, and a developing tank cover with agitator. Users desiring a customized processing outfit may order the appropriate additional components.

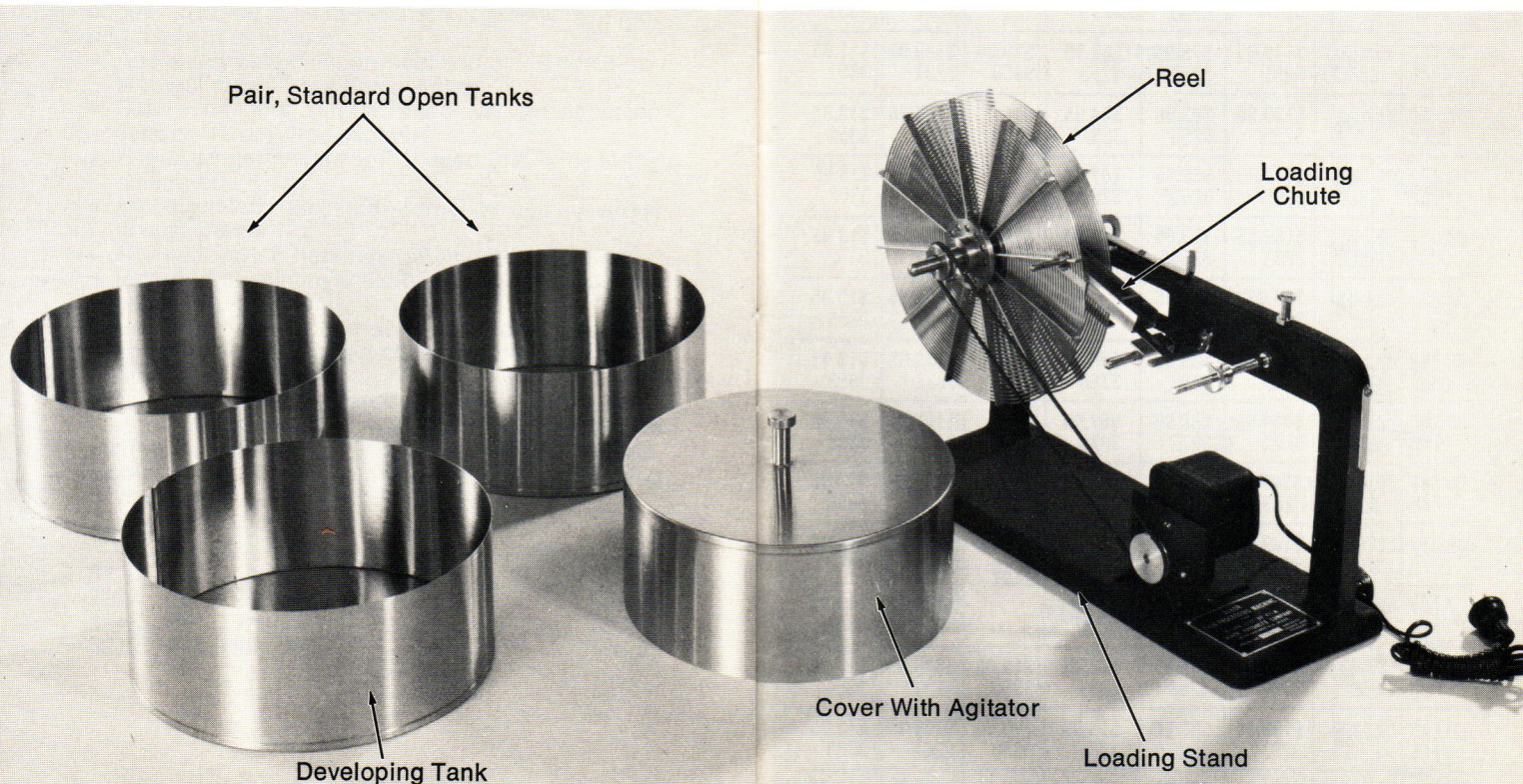

# Honeywell Nikor Film Processing Equipment

	Reel	Developing Tank & Cover	Pair Standard Open Tanks	Floating Lid	Loading Stand	Loading Chute	
16mm	28'	\$139.95 3230*	\$62.95 3232*	\$54.95 3233*		\$109.95 3231	
	50'	\$144.95 3235	\$66.95 3236	\$57.95 3237*		\$109.95 3231	
	100'	\$149.95 3239	\$73.95 3240	\$62.95 3241	\$19.50 3350	\$109.95 3231	
35mm	18'	\$39.95 3086	\$34.95 3050	Use Std. 3½ gal. Tank		\$109.95 3231	\$11.95 3351
	28'	\$139.95 3243	\$62.95 3244	\$54.95 3245		\$109.95 3231	\$11.95 3351
	50'	\$144.95 3247	\$66.95 3248	\$57.95 3249		\$109.95 3231	\$11.95 3351
	100'	\$149.95 3251	\$73.95 3252	\$62.95 3253	\$19.50 3350	\$109.95 3231	\$11.95 3351
46mm	28'	\$139.95 3255*	\$62.95 3256*	\$54.95 3257*		\$109.95 3231	\$13.95 3352
	50'	\$144.95 3259*	\$66.95 3260*	\$57.95 3261*		\$109.95 3231	\$13.95 3352
	100'	\$149.95 3263	\$73.95 3264*	\$62.95 3265	\$19.50 3350	\$109.95 3231	\$13.95 3352
70mm	18'	\$39.95 3087	\$37.95 3054	Use Std. 3½ gal. Tank		\$109.95 3231	\$13.95 3353
	28'	\$139.95 3267	\$62.95 3268	\$54.95 3269		\$109.95 3231	\$13.95 3353
	50'	\$144.95 3271	\$66.95 3272	\$57.95 3273		\$109.95 3231	\$13.95 3353
	80'	\$149.95 3283	\$73.95 3276	\$62.95 3277	\$19.50 3350	\$109.95 3231	\$13.95 3353
	100'	\$149.95 3275	\$73.95 3276	\$62.95 3277	\$19.50 3350	\$109.95 3231	\$13.95 3353
89mm	18'	\$39.95 3088	\$39.95 3057	Use Std. 3½ gal. Tank		\$109.95 3231	\$13.95 3354
	80'	\$179.50 3287	\$85.95 3288	\$72.95 3289	\$19.50 3350	\$109.95 3231	\$13.95 3354
105mm	80'	\$199.95 3291*	\$95.95 3280*	\$79.95 3281*	\$19.50 3350	\$109.95 3231	\$13.95 3355
	100'	\$199.95 3279*	\$95.95 3280*	\$79.95 3281*	\$19.50 3350	\$109.95 3231	\$13.95 3355

Loading Guide Fork	Loading Stand Reel Adapter	Loading Stand Sleeve Adapter	Lift Rod	Pentax 250 Cassette Adapter for Loading Stand	Linhof Cassette Adapter for Loading Stand	Control Strip Holder	Drying Motor	Roto Wash Tank
\$4.00 3356							\$54.95 3358	\$85.50 3359
\$4.00 3356							\$54.95 3358	\$85.50 3359
\$4.00 3356							\$54.95 3358	\$85.50 3359
	\$11.95 3134	\$4.95 3135	\$1.00 3375				\$54.95 3358	\$85.50 3359
				\$21.95 3389			\$54.95 3358	\$85.50 3359
				\$21.95 3389			\$54.95 3358	\$85.50 3359
				\$21.95 3389			\$54.95 3358	\$85.50 3359
							\$54.95 3358	\$85.50 3359
	\$11.95 3134		\$1.00 3136		\$21.95 3388		\$54.95 3358	\$85.50 3359
					\$21.95 3388	\$14.55 3378	\$54.95 3358	\$85.50 3359
					\$21.95 3388	\$14.55 3378	\$54.95 3358	\$85.50 3359
					\$21.95 3388	\$14.55 3378	\$54.95 3358	\$85.50 3359
					\$21.95 3388	\$14.55 3378	\$54.95 3358	\$85.50 3359
	\$11.95 3134		\$1.00 3377				\$54.95 3358	\$85.50 3359
						\$13.55 3357	\$54.95 3358	\$85.50 3359
							\$54.95 3358	\$85.50 3359
							\$54.95 3358	\$85.50 3359

\* Special Item—Delivery information on request.

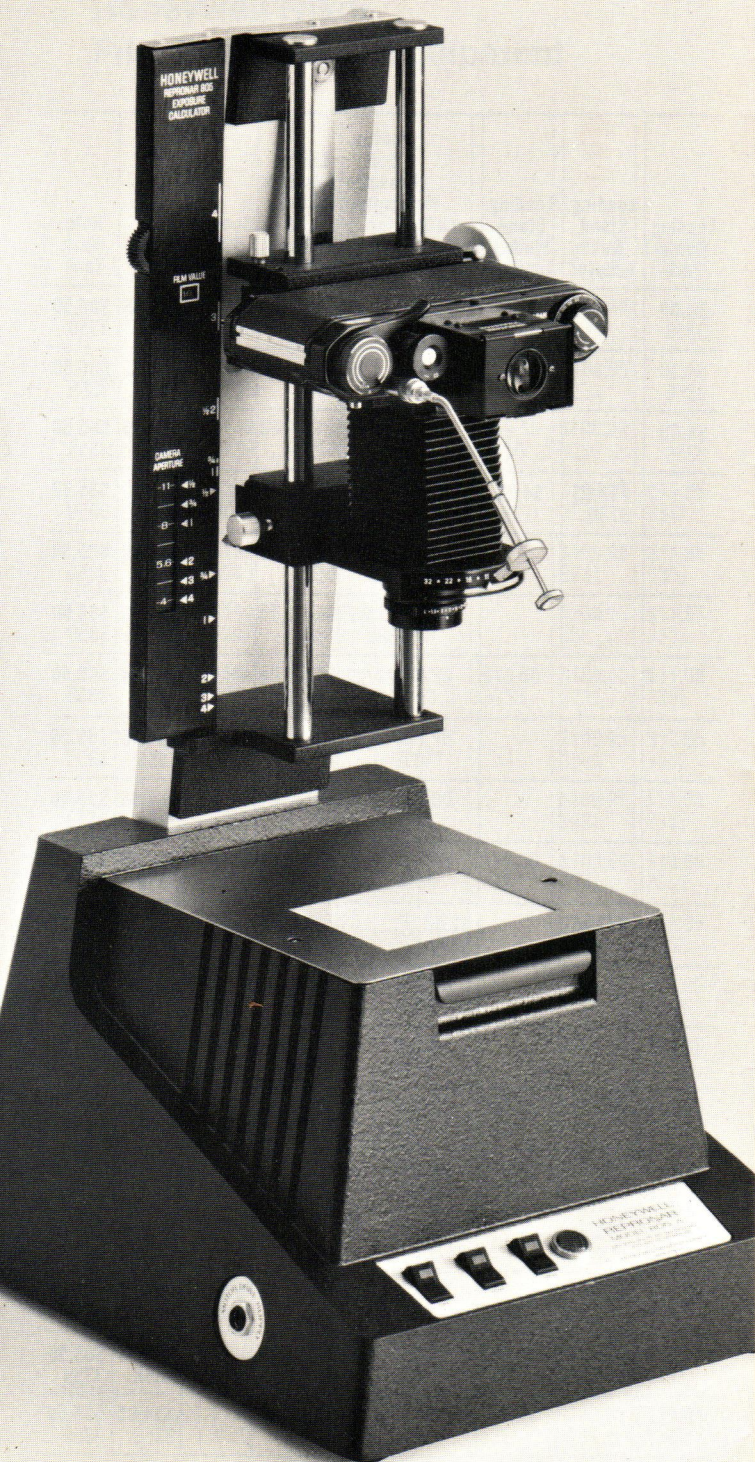

## Honeywell Repronar Model 805 Slide Duplicator

Slide duplication is only one of many versatile, moneysaving uses of the Repronar 805. It performs a variety of processes, both functional and creative, at far less cost than an outside laboratory.

- Crop and enlarge for better, more dramatic composition. The Repronar will enlarge up to four times original copy size.
- Reduce 2¼" slides to 35mm.
- Correct underexposure or overexposure to salvage a valuable slide.
- Correct color balance, using filters, with the Repronar; or add new colors for exciting effects.
- Increase or reduce contrast to improve slides or add special effects.
- Dodge for exposure control to eliminate or correct an area on original slide.
- Vignettes with the Repronar make interesting, subtle or artistic shots.
- Create montages for another unusual effect. A grease pencil can be used on the ground glass viewer to aid composition.
- Add texture, using screen or other items, for another special effect.
- Dramatize an ordinary shot by tilting for unusual composition.
- Create sandwich effects by placing two or more transparencies in the slide carrier, copy as one.
- Double or multiple exposures are simple to make.
- Titles and captions are easily created and give clarity and professionalism to slide presentations.
- Correct distortion in pictures where buildings or other objects seem to lean.
- Frame pictures with masks for dramatic or comic effect.
- Black-and-white films can be used with the Repronar. Black-and-white transparencies can be made from negatives or transparencies, both color or black-and-white. Negatives can be made from color or black-and-white transparencies.
- Optional accessories include a film strip kit, motor drive and 100-foot bulk film back.

Basically, the Repronar 805 is a special purpose 35mm camera, an easel with slide and filter holders, electronic flash light source, an incandescent light source and an adjustable exposure calculator. It's one of the most versatile and useful photographic tools you can own, whether for duplicating slides or performing a variety of creative techniques.

### Cat. No.

805 Honeywell Repronar 805  
Slide Duplicator . . . . . \$650.00

*Prices subject to change without notice. 12/73*