

WILSONWERKS ARCHIVES

This camera manual is for reference and historical purposes, all rights reserved.

This cover page is copyrighted material. This document may not be sold or distributed without the express consent of the publisher.

©2008 wilsonwerks Llc

KONICA
AUTOREFLEX **T**



CONTENTS

Seven Basic Steps	3	Hints for Unusual Exposure Situations	23
Operating Controls	4	Holding Your Camera	24
Major Specifications	6	Focusing Your Subject	25
Inserting Batteries, and Meter Switch	8	Depth-of-Field, and Self-timer	26
Film Loading	10	Depth-of-Field Tables	28
Shutter and Aperture	13	Film Rewind	29
Automatic and Non-automatic Controls	15	Flash Photography	30
“Control Center” Viewfinder	16	Time Exposures	31
AEC: Automatic Exposure Control	18	Changing Lenses	32
Safety Indicators in Viewfinder	20	Hexanon Interchangeable Lenses	33
Optional Stopped-down Aperture Metering	21	Filters	35
Using Preset or Manual Lenses	22	Accessories	36



SEVEN BASIC STEPS TO PLEASURABLE AEC* SHOOTING

1. Insert the two 1.3 Volt mercury batteries supplied with your camera into chamber at bottom of camera to power the CdS meter. Turn switch to "on" position (red dot) when shooting pictures.
2. Load camera. Here "Insta-Grip" take-up spool makes for sure, fumble-free operation.
3. Set ASA rating of your film in window on the top of the shutter speed dial, by lifting and turning outer ring.
4. Make certain that lens is set at "EE" for effortless, correct shooting, when automatic exposure is desired.
5. Select desired shutter speed. For most outdoor shots, 1/125 is recommended.
6. Focus and compose picture in finder. The bright image is easy to focus, especially in the Micro Diaphragm area, where images snap in and out of focus smartly.
7. Shoot the pictures, as long as the needle in the right margin of the finder is in a white area.

*AEC describes the optional total Automatic Exposure Control of the KONICA AUTOREFLEX-T which permits (1) Full use of wide open automatic aperture lenses, (2) automatically selects and sets proper aperture at instant of exposure, (3) automatically reopens aperture, and (4) provides Instant Return Mirror action.

OPERATING CONTROLS

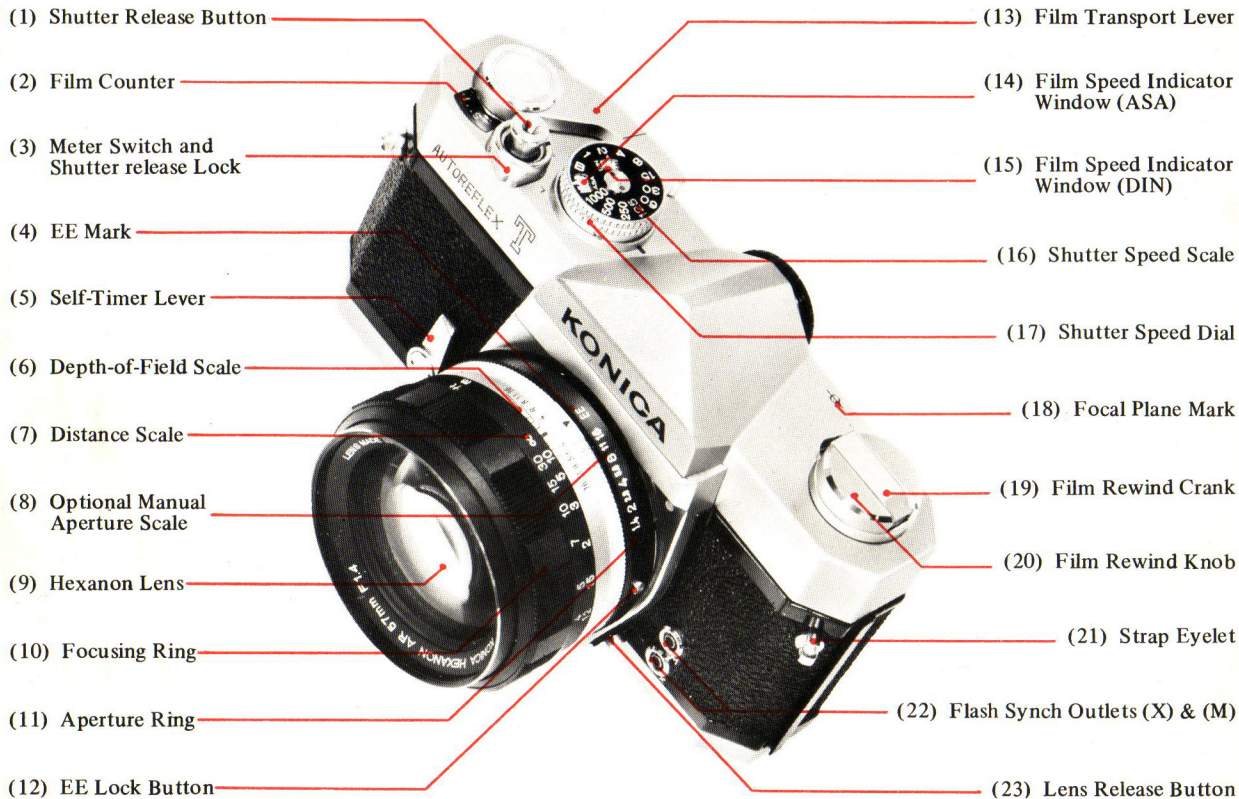

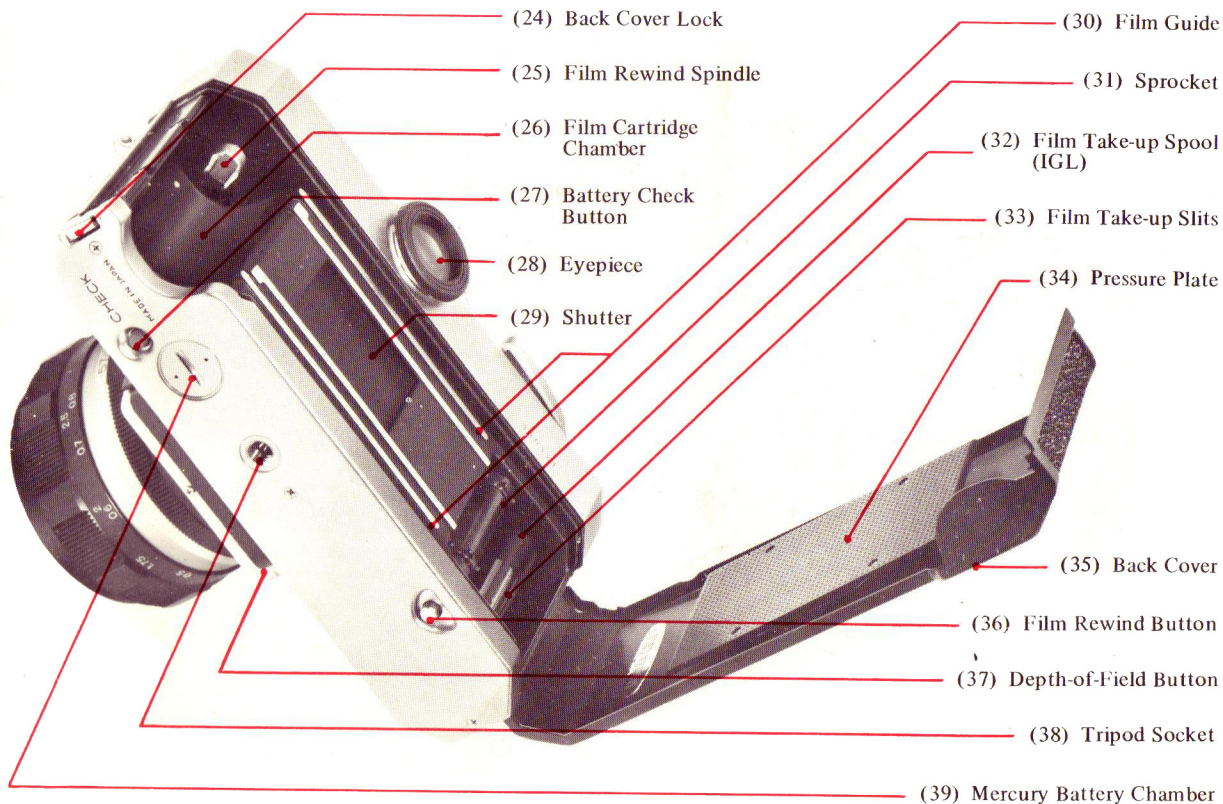

MAJOR SPECIFICATIONS FOR KONICA AUTOREFLEX-T

Camera Type: Precision, professional 35mm SLR with metal focal plane shutter and fully automatic CdS Through-The-Lens exposure meter operation.

Picture Size: 24 × 36mm (1" × 1-1/2").

Film: Standard 35mm cartridges, 20 or 36 exposure.

Standard (Normal) Lenses: Hexanon AR 57mm f/1.2 (7 elements in six groups); Hexanon AR 57mm f/1.4 (6 elements in five groups); Hexanon AR 52mm f/1.8 (6 elements in five groups); All focus from infinity to 18 inches.

Lens Mount: KONICA bayonet mount Type II. Diameter 47mm. Flange to film distance, 40.5mm.

Diaphragm Action: Fully automatic diaphragm. Automatic EE lenses reopen to full aperture for focusing and exposure metering. Manual aperture control and Depth-of-Field preview button provided.

Shutter: Hi-Synchro Metal Copal Square S. "B" (Bulb), 1 to 1/1000 second, in even 1:2 progression. Shutter speed dial on top of camera. Shutter Release locks when Meter Switch (3) is in locked (L) position.

X – synchro for electronic flash to 1/125 second;

M – synchro for flashbulbs to 1/1000 second.

Viewfinder: Eye-level pentaprism. Extremely bright. Has central Micro Diaphragm area surrounded by plain ground glass circle. Balance is fine, almost invisible fresnel ground glass area. Meter needle, f/stops, shutter speed, battery check, index point for stopped-down metering, under- and overexposure marks, automatic and non-automatic mode signal visible outside focusing/viewing area.

Mirror Action: Vertical travel, instant return.

Exposure Metering: Center weighted dual CdS, Through-The-Lens. KONICA Hexanon AR lenses stop down automatically after shutter release is depressed. No need to match needle to a mark. Focusing, metering at full lens aperture. Meter system coupled to film and shutter speeds. *With manual and preset lens operation*, lens is stopped-down or Shutter Speed Dial (17) turned until meter needle reaches index mark (opposite f/1.4) in Viewfinder. Battery check visible in Viewfinder.

EE Coupling Range: EV 1.5 (f/1.2 with 1/2 sec.) to EV 18 (f/16 with 1/1000 sec.) at ASA 100 for f/1.2 lens.

Film Sensitivity Range: ASA 25 to 1600 (DIN 15 to 33).

Film Wind: Single stroke lever, cocks shutter and transports film. 162° stroke. In operation, lever stops 30° from body position for fast shooting without removing eye from camera.

Film Counter: Resets self to "Start" automatically as camera back is opened. Indicates number of shots exposed. Dial is under glass, protected against dust and dirt.

Film Rewind: Film rewind crank. Rewind Button (36) in base of camera remains depressed during rewinding

Dimensions and Weight:

- with f/1.8 lens: 5-3/4" (wide) × 3-3/4" (high) × 3-1/2" (deep). 34 ozs.
- with f/1.4 lens: 5-3/4" (wide) × 3-3/4" (high) × 3-1/2" (deep). 36 ozs.
- with f/1.2 lens: 5-3/4" (wide) × 3-3/4" (high) × 3-3/4" (deep). 43 ozs.

INSERTING BATTERIES, AND METER SWITCH

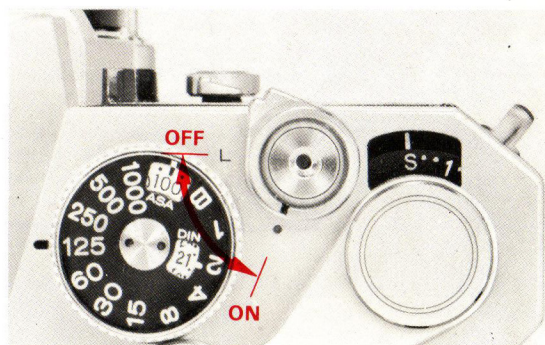
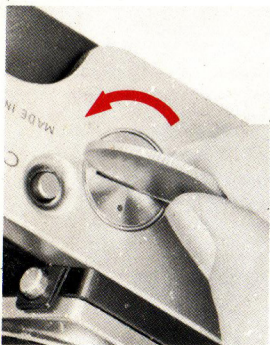

INSERTING BATTERIES

The compound CdS meter of the KONICA Autoreflex-T operates on two Mallory No. PX-675 or Eveready EPX-675 or equivalent 1.3V mercury batteries. Handle batteries by edges to keep current conducting surfaces clean. If soiled, wipe clean with soft, dry cloth.

Turn the cover of the Mercury Battery Chamber (39) counterclockwise with a coin and detach it from the chamber.

Insert the two cells into the Mercury Battery Chamber, the "+" side up, according to the figure printed on the seal, inside the chamber.

After the cells have been put into position, put the cover on the chamber and screw it tightly.

METER SWITCH

The meter switch and Shutter Release Lock (3) are combined in a single lever encircling the shutter release button. When the lever is rotated so that the black index mark lines up with the red mark on the camera body, the meter battery is turned "on" and the shutter may be released.

When camera is not in use, the lever should be rotated so that the black index mark lines up with "L" (lock) mark on the camera. This switches the mercury battery off, and locks against accidental exposure.

- The meter uses two 1.3V, Mallory PX-675 or Eveready EPX-675 Mercury battery cells. Be certain not to use similar looking batteries of different voltages.
- When not using the camera for a length of time, remove the battery cells and store them in a cool, dry place.

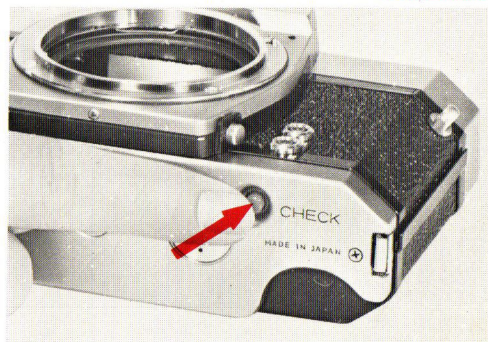
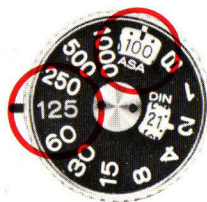

The service life of a mercury battery is generally over one year of normal use. Therefore it is not necessary to check battery strength frequently.

If the meter needle fails to swing when switch is "on" and camera aimed at light, (ASA 400, shutter 1/125) make battery check as follows:

BATTERY CHECK

Remove automatic lens by depressing Lens Release Button (23), grip lens by silver-colored band and rotate it counter-clockwise. It is not necessary to remove manual or preset (non-EE) lenses for battery check purposes.

Lift outer ring surrounding Shutter Speed Dial (17) and turn it to set ASA 100 in Film Speed Indicator Window (14).

Set Shutter Speed Dial at 1/125 sec.

Depress the red Battery Check Button (27) on underside of camera while looking into Viewfinder. If meter needle in finder stops at the Battery Check Mark (46) between f/8 and f/11 or beyond the check mark towards f/16, batteries are serviceable. If not, replace immediately.

Batteries may be checked with Meter Switch in "on" (red dot) or "off" (L) position.

FILM LOADING

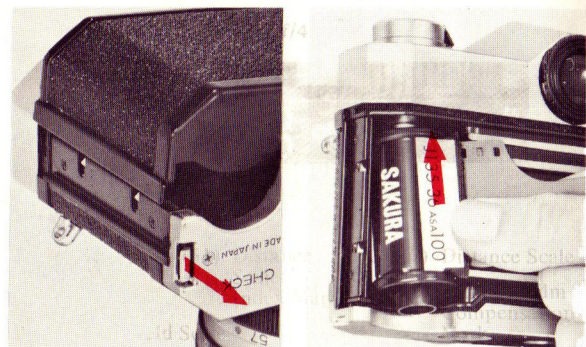

The KONICA Autoreflex-T takes standard 35mm film cartridges.

When loading avoid direct sunlight. Try to load camera in the shade. If no shade is available, use your own body to shade the camera.

- 1** Pull the Back Cover Lock (24) and open the Back Cover (35) of the camera.
- 2** Place the film cartridge in Film Cartridge Chamber (26) as shown in illustration (above, right).

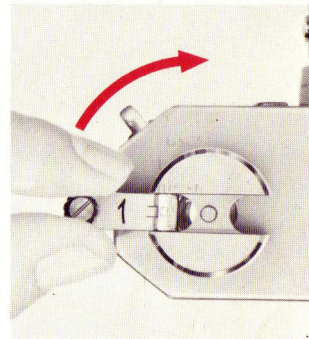
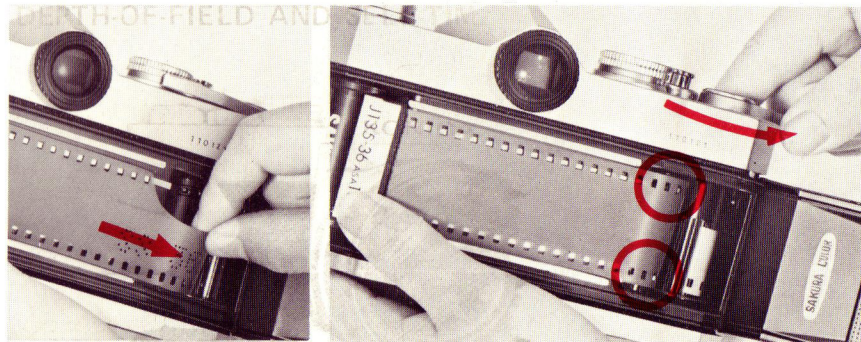

3 Draw film leader across film gate and insert tip into any Slit (33) in the Film Take-up Spool (IGL—Insta-Grip Loading) (32). The film will be gripped instantly as you . . .

4 Wind one turn of film onto the Take-up Spool by turning the Film Transport Lever (13) Make sure that the Sprocket Holes in the film engage the Sprockets (31) in the camera before closing the camera back.

5 After closing the camera, turn the Film Rewind Crank (19) gently clockwise to take up the slack of the film in the cartridge.

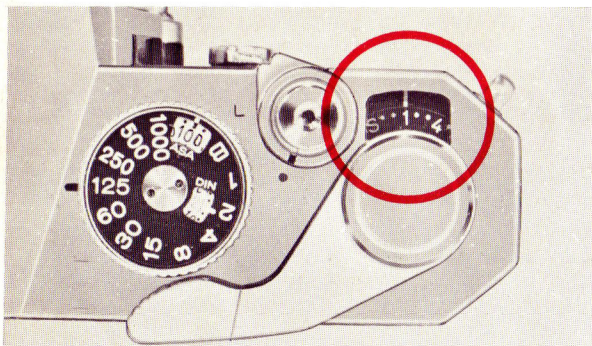

- 6** To wind off the exposed film leader, operate the Film Transport Lever (13) several times, alternately depressing the Shutter Release Button (1) until No. 1 appears opposite the mark in the Film Counter Window (2).

A single stroke of the Film Transport Lever moves the film one frame forward, cocks the shutter, and advances the film counter. The latter indicates the number of pictures that have been taken. At the end of shooting, after the film has been rewound, opening the camera back automatically returns the film counter to "S" (Start) position.

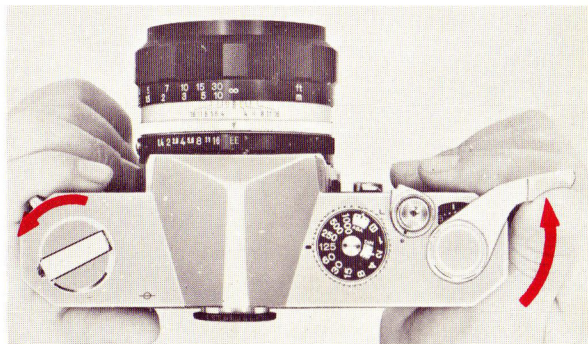

TO CHECK FILM ADVANCE

Movement of the Film Rewind Knob (20) may be observed to check if film is moving through the camera. First the slack must be taken out of the film, as described on page (11). If film is moving through the camera, the Film Rewind Knob will rotate counterclockwise.

SHUTTER AND APERTURE

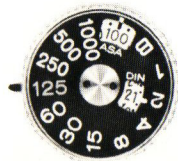

The KONICA Autoreflex-T is equipped with an all-metal, Hi-Synchro Copal Square S focal plane shutter. It controls the length of time that light is permitted to enter the camera and expose the film. A unique feature of the Copal Square S shutter mounted in the KONICA Autoreflex-T is that the Shutter Speed Dial (17) is located on top of the camera, where shutter speeds are changed with the camera at eye level for more convenient operation. The Copal Square S shutter is noted for extreme split second accuracy. Shutter speeds are linearly proportional as follows: 1, 1/2, 1/4, 1/8, 1/15, 1/30, 1/60, 1/125, 1/250, 1/500, and 1/1000 second, plus "B" (Bulb), used for exposures of more than 1 second duration.

The Copal Square S shutter is synchronized for electronic flash speeds up to 1/125 second. This figure is marked in red on the shutter speed dial. Expendable flashbulbs of "M" and "FP" types may be used at all speeds up to and including 1/1000 second.

The "B" (Bulb) is used to make exposures longer than 1 second. A tripod or other support should be used for "B" and for all shutter speeds slower than 1/30 second.

KONICA
AUTOREFLEX T

F-number

1.2 1.4 i.8 2 2.8 4 5.6 8 11 16



Amount-of-
Light Ratio

2 1 $\frac{1}{2}$ $\frac{1}{4}$ $\frac{1}{8}$ $\frac{1}{16}$ $\frac{1}{32}$ $\frac{1}{64}$

Intermediate speeds cannot be set on the Copal Square S shutter. However, speeds may be changed before or after cocking the shutter.

The amount of light that is allowed to enter the camera and strike the film is controlled by the iris diaphragm. The relative size of the opening or aperture is usually indicated by the use of *f*/stops. The larger the *f*/stop number the less light admitted. Thus *f*/16 admits less light than *f*/4.

When a KONICA Hexanon AR (EE) lens is mounted on the Autoreflex-T, the aperture is automatically closed to the correct *f*/stop after the shutter release is pressed. The needle in the window indicates the *f*/stop to which the aperture will close at the moment of exposure by the AEC (Automatic Exposure Control), through-the-lens exposure meter system. It is not necessary to match the needle to a mark when the EE lenses are used.

Preset and manual diaphragm lenses may also be used with the AEC metering system. With these, the diaphragm is stopped down manually until the meter needle is opposite the mark near the *f*/1.4 setting in the finder.

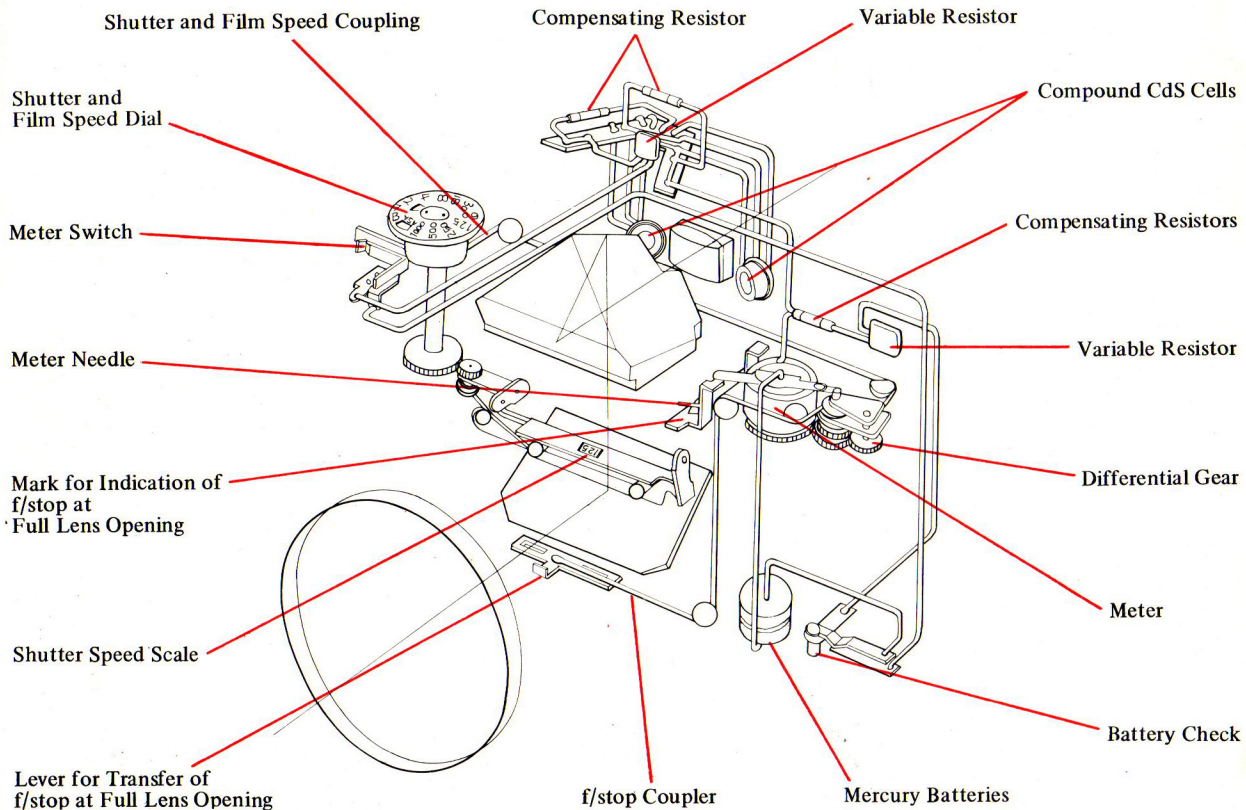

AEC (AUTOMATIC EXPOSURE CONTROL) METERING AND NON-AUTOMATIC CONTROLS

KONICA
AUTOREFLEX 

The Autoreflex-T is the world's first professional Through-The-Lens metering 35mm Single-Lens Reflex camera to have fully automatic AEC exposure control. The AEC meter system establishes contact to all KONICA Hexanon AR lenses by means of a meter-actuated coupling lever. When the shutter release is depressed, the spring loaded aperture in the lens is tripped to close to the limit determined by this coupling lever. This limit is the precise aperture required for a perfect exposure at that instant when you press the button.

With a KONICA Hexanon AR lens installed in your Autoreflex-T there is no need to waste time before shooting to match the needle to a mark. You only need to focus and compose, then press the shutter release—remaining assured all the time that correct exposure is being taken care of. Full concentration can thus be made on the spontaneous or esthetic needs of your photography. *In actuality, the KONICA Autoreflex-T offers not one but three optional methods of arriving at the correct or desired exposure.*

AEC Metering: With a KONICA Hexanon AR (Electric-Eye) lens, the needle in the viewfinder serves only to let you know at which f/stop the fully automatic metering system will make the picture for you. Shutter and diaphragm are cross-coupled. Thus if you choose a high shutter speed to stop action, the diaphragm will be set for a wider opening automatically. On the other hand, should you need a smaller stop for greater Depth-of-Field, simply turn the Shutter Speed Dial (17) to a slower speed. The needle in the information center of the Viewfinder will keep you informed. At the same time, you can read the shutter speed setting below the viewing area (see page 17).

Stopped-Down Exposure Metering: With KONICA and other lenses having manual or preset diaphragm (not EE), as well as with extension tubes and bellows, the Stopped-Down method is used. Here the exposure is read at the actual aperture used to make the picture. The needle in the Control Center is then simply brought to the Index Mark opposite the f/1.4 figure. This can also be done by changing the shutter speed setting. Literally thousands of lenses can be used with this system. In addition to KONICA Autoreflex lenses, lenses in mounts for KONICA FP, Pentax/Praktica, Exakta/Topcon and Nikon/Nikkormat can be used for the Stopped-Down metering with the Autoreflex-T via their respective KONICA Lens Adapters.

Manual Exposure Settings: Should you have some special exposure idea in mind, you need only move the diaphragm ring of your KONICA Hexanon AR lens from the EE setting to any f/stop desired. Thus, with this and the other metering systems just discussed, exposure with the KONICA Autoreflex-T becomes a versatile tool which gives you freedom to exploit its automation or to choose other exposure methods. (See page 21).

NOTE: With extremely fast films, the electric eye of the Autoreflex-T will not couple to the wider apertures of the lens diaphragm at very slow shutter speeds. This is automatically indicated in the viewfinder which shows the maximum apertures at which the meter is coupled under those conditions.

"CONTROL CENTER" VIEWFINDER

CORRECT EXPOSURE RANGE FOR f/1.2 HEXANON LENSES: With a Hexanon AR f/1.2 lens mounted on the KONICA Autoreflex-T, correct exposure will be obtained so long as the needle is opposite or between f/numbers in the white portion of the scale. Underexposure will result when the needle swings into the upper red area (40). Overexposure will result when the needle swings into the lower red area (48).

CORRECT EXPOSURE RANGE FOR LENSES SLOWER THAN f/1.2: When a KONICA Autoreflex-T lens, slower than f/1.2 is installed on the camera, a red Maximum Aperture Indicator Band (44) will drop into place (i.e. In the diagram at the right, the maximum aperture indicator shows that the maximum aperture available is f/1.8). With lenses slower than f/1.2, the needle must be in a white area below the maximum aperture indicator.

BATTERY CHECK MARK: The Battery Check Mark (46) is located between f/8 and f/11. See instructions for checking battery strength on page 9.

INDEX POINT FOR STOP-DOWN READINGS: This is used when Non-Electric-Eye (EE) lenses are mounted on the Autoreflex-T. In this case the lens is set for manual operation and the diaphragm ring turned until the meter needle is opposite the Index Point for Stopped-Down Lens Aperture (41). If it is desired to work at a fixed f/stop, the needle can be brought into place by changing the shutter speed.

MANUAL APERTURE INDICATOR: When a Non-Electric-Eye (EE), manual or preset diaphragm lens is mounted on the KONICA Autoreflex-T, or extension tubes and bellows are used, a white letter "M" (43) appears at the top of the scale. When the "M" is visible, the Stop-Down method of exposure determination must be used as described above.

NOTE: Hexanon AR (EE) lenses for previous KONICA Auto-Reflex cameras may be modified to work properly with the Autoreflex-T AEC exposure automation. Your dealer can give you full information and service, or you can contact our service centers.

(40) Underexposure Warning for f/1.2 Lens

(43) When in Non-Automatic Exposure Mode, an “M” Appears here.

(41) Optional Stopped-Down Metering Index Mark

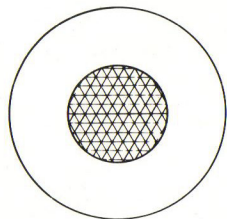

M

f/1.2 Mark

1.4

(44) Maximum Aperture Indicator

2

2.8

(45) Meter Needle

4

5.6

8

11

(46) Battery Check Mark

16

(47) Aperture Scale

Correct Exposure Range
for f/1.2
for f/1.8

250

(42) Shutter Speed Scale

(48) Overexposure Warning

AEC: AUTOMATIC EXPOSURE CONTROL

Full Aperture, AEC Metering:

The focusing screen of the KONICA Auto-reflex-T is always at maximum brightness when a KONICA Hexanon AR (EE) lens is used, since exposure determination is made with the lens at its widest or maximum aperture.

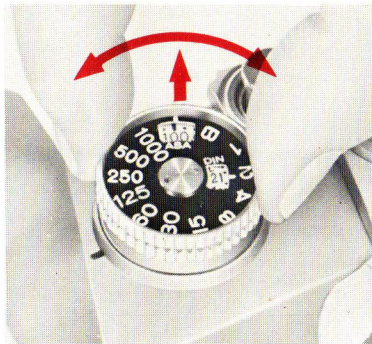

The correct ASA or DIN film speed setting must be set in the Film Speed Indicator Window (14) on top of the Shutter Speed Dial (17), before taking pictures in order to obtain correct exposure. ASA and DIN ratings for the film you use will be found on the carton, or on instruction sheet packed with the film of your choice.

1 Set the film speed (ASA or DIN)

Lift the outer collar surrounding the Shutter Speed Dial (17) and turn it to the left or right until the correct ASA or DIN value shows in the respective Film Speed Indicator Window (14) on top of the Shutter Speed Dial. When aligned properly, the collar will drop into place.

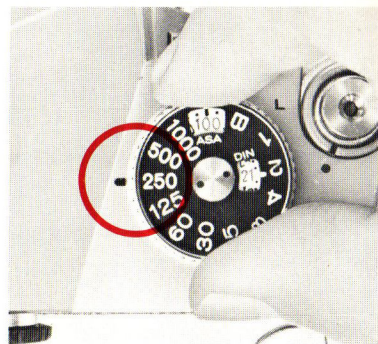

2 Determine the shutter speed

Select the proper shutter speed. Outdoors, 1/125 is a good choice, 1/30 for indoors. The higher the shutter speed, the better the action-stopping power. Use of a slower shutter speed results in a smaller aperture and greater Depth-of-Field.

The figures in brackets in the chart at right are intermediate values for film speeds indicated only by dots on the film speed scale.

	(1250)	(1000)	(640)	(500)	(320)	(250)	(160)	(125)	(80)	(64)	(40)	(32)
ASA	1600	. . 800	. . 400	. . 200	. . 100	. . 50	. . 25					
DIN	33	. . 30	. . 27	. . 24	. . 21	. . 18	. . 15					
		(32)(31)	(29)(28)	(26)(25)	(23)(20)	(20)(19)	(17)(16)					



3 Make certain the Aperture Ring (11) is set at "EE" (Electric-Eye). If set incorrectly the letter "M" will automatically appear above the Meter Scale.

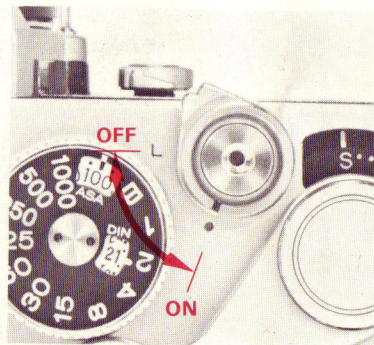

4 If the needle fails to swing, you've forgotten to place the Meter Switch at "on" position (red dot).

When the camera is not in use, make sure that the meter switch is set to "L"

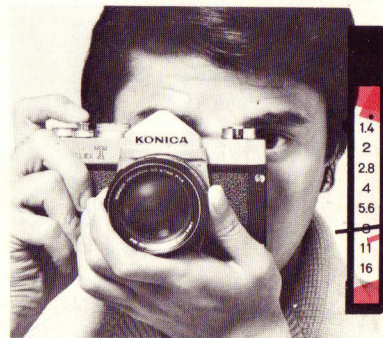

5 Aim the camera at your subject and look through the Viewfinder. The meter needle in the information center band at the right will point to the f/stop at which the aperture will set itself at the instant of exposure.

If the Meter Needle (45) is in the correct exposure range (see page 17) you're ready to shoot a correctly exposed picture.

SAFETY INDICATORS IN VIEWFINDER

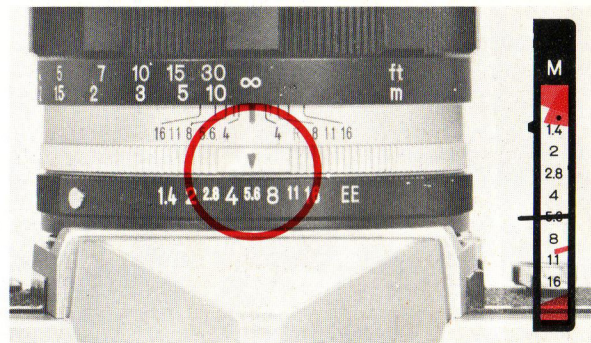
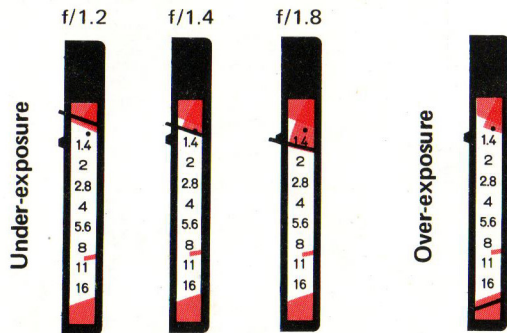

When the meter needle indicates an underexposure, choose a slower shutter speed. When it indicates an overexposure, select a faster shutter speed. This can be done without removing the camera from your eye. You simply rotate the Shutter Speed Dial (17) watching the Shutter Speed (42) in the viewfinder. Pictures may be taken under the AEC (EE) system, as long as the needle is visible somewhere within the correct exposure range. If a full turn of the Shutter Speed Dial does not drive the meter needle to come within the correct exposure range, pictures cannot be taken under the AEC (EE) system. However, pictures may sometimes be taken by setting the camera in non-automatic mode.

If you wish to use a specific lens aperture, for example, a small aperture for greater Depth-of-Field or a large aperture to throw backgrounds out of focus, turn the shutter speed dial until the needle is opposite the desired aperture. Make sure that the shutter speed dial clicks into place at the desired shutter speed. When shooting for Depth-of-Field, make sure to use a tripod if you are shooting at slower than 1/30 second to prevent blur caused by camera movement.

When the Electric-Eye is not used ...

To set the diaphragm manually, simply rotate the Aperture Ring (11) to the right, while depressing the EE Lock Button (12) on the aperture ring until the desired f/stop is opposite the index mark. Manual diaphragm setting is helpful when a deliberate under- or overexposure is desired for some special effect. During manual operation the letter "M" will appear above the f/stop scale. For normal AEC (EE) operation, remember to return the aperture ring to "EE", where it will lock in place automatically.

OPTIONAL STOPPED-DOWN APERTURE METERING

KONICA
AUTOREFLEX

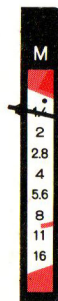
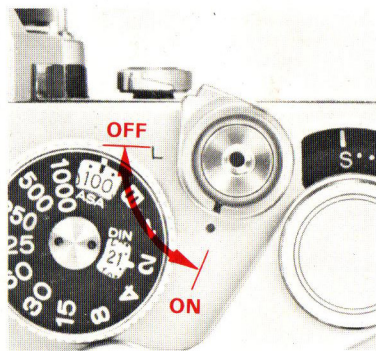
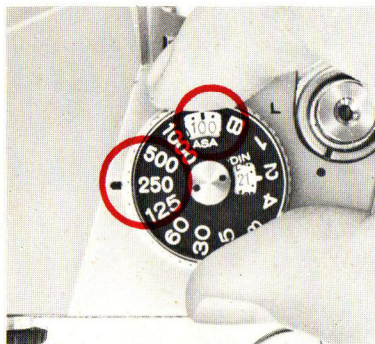

When preset or manually operated KONICA Hexanon lenses are used, or when KONICA FP*, Pentax/Praktica, Exakta, or Nikon lenses are used via KONICA adapters, the stopped-down method of determining correct exposure is used. This method is also used when extension tubes or bellows are employed in close-up photography.

1 SET THE FILM SPEED (ASA or DIN)

Lift and turn the outer collar around the Shutter Speed Dial (17), until the appropriate ASA or DIN rating is in the Film Speed Indicator Window (14) or (15).

2 CHOOSE A SHUTTER SPEED

3 MAKE SURE THE METER SWITCH IS IN "ON" POSITION (RED DOT).

4 DETERMINE THE EXPOSURE

Turn the Aperture Ring (11) on your lens to the left or right until the Meter Needle (45) lines up with the Index Mark (41) opposite f/1.4 in the Viewfinder.

If you wish to work at a fixed aperture, set the aperture ring and then turn the Shutter Speed Dial (17) until the Meter Needle is opposite the index mark. The shutter speed is visible in the viewfinder.

* FP-FM-FS-F series of KONICA SLR cameras

USING PRESET OR MANUAL LENSES

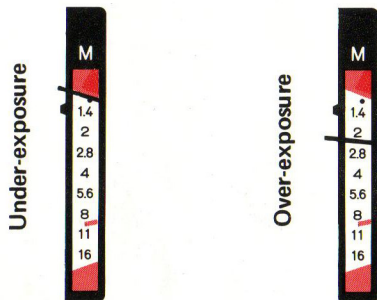

The *f*/stop settings in the Viewfinder are not used when the stopped-down method of exposure determination is employed. Occasionally the Meter Needle will not come to rest opposite the Stopped-Down Index Mark (41) no matter in which direction the Aperture Ring (11) is turned. In this case, adjust the Shutter Speed Dial (17) until the needle lines up with the Index Mark.

In photomicrography the Meter Needle is brought to the Index Mark by adjusting the light and the shutter speed.

When using Hexanon reflex mirror optics lenses, the Meter Needle is brought to the index by bringing the appropriate neutral density filter into place, or by adjusting the shutter speed. These lenses do not have an iris diaphragm.

When stopping a lens down for close-ups, keep your eye against the Viewfinder eyepiece to protect the latter from the entry of strong light.

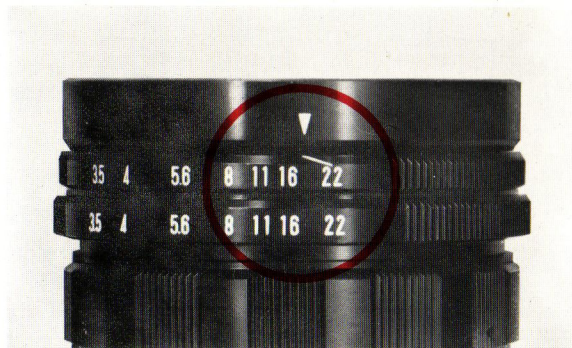

When a manual preset lens is to be used ...

For convenience with preset diaphragm lenses, set the preset selector ring to the smallest aperture. This will then allow the diaphragm setting ring to ride free to any desired setting in the lens range.

HINTS FOR UNUSUAL EXPOSURE SITUATIONS

KONICA
AUTOREFLEX

The compound dual CdS metering system in the Autoreflex-T is very selective, and is generally not unduly affected by subject matter outside its primary exposure reading range. It is programmed to obtain its primary exposure data from the main subject area. This is deemed to be the lower center third of the total area. The peripheral upper and marginal two thirds contributes in a lesser degree to the compound exposure data. There are however a number of unusual situations that require special handling.

Against-the-Light Shots: In such situations the light can shine directly into the camera and adversely affect readings for the main portion of the subject. In most cases *temporarily* changing the film speed setting to a value one-half ($1/2$) that of the actual film speed will give an extra stop exposure to correct the situation. In extreme cases, use the regular film speed but move the camera in close to read the important subject areas. After taking a reading, depress the Shutter Release Button partially, which will lock the meter needle at the close-up reading; move back, and then depress the Shutter Release Button the rest of the way to make the exposure.



Very Light or Dark Backgrounds:

When a small light subject is against a large dark background, the meter may read the entire area as a dark subject and overexpose the main subject. Conversely, with a small dark subject against a large light background, the meter may read the entire area as a light subject and underexpose the main subject. In this case, a close-up reading as described under "Against-the-Light Shots" can be found helpful.

NOTE: Should you temporarily change the ASA setting to get more exposure in backlit situations, do not forget to reset your meter to the normal rating for regular shots.



HOLDING YOUR CAMERA

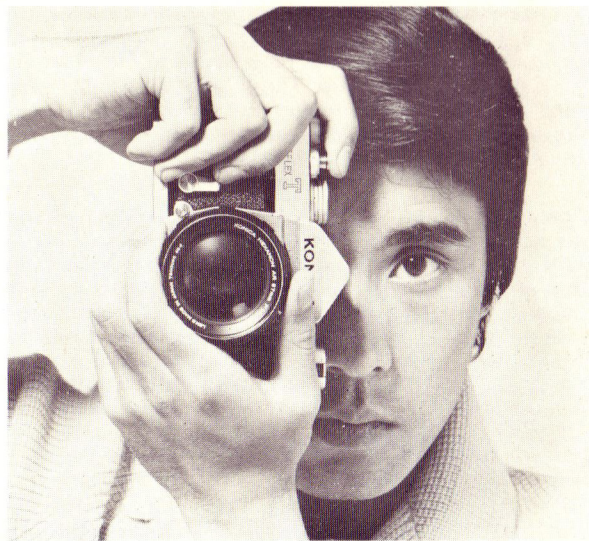

- **Hold the Camera securely – comfortably for your hand**

One secret for getting ultra-sharp pictures is to prevent accidental camera movement. To do this it is suggested that you hold the camera firmly, as shown in the picture above, cradling the body of the Autoreflex-T against the face. Depress the shutter release button firmly but gently. Do not punch the shutter release button but squeeze the exposure off smoothly for “jar-free” operation.

Vertical shots add variety to a series of pictures. They are especially desirable when making head and shoulder portraits and architectural shots. Hold the camera as shown above. This position prevents accidentally pushing the lens release button.

FOCUSING YOUR SUBJECT

KONICA
AUTOREFLEX T

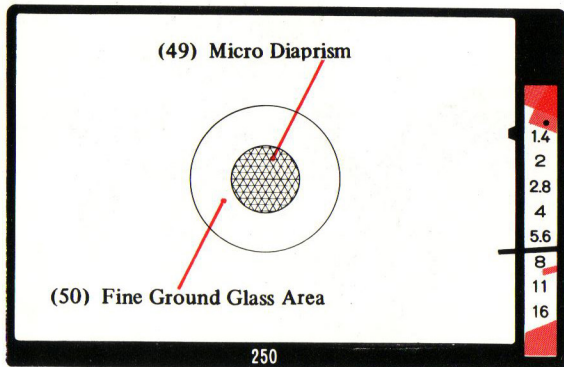

The ultra brilliant focusing screen of the KONICA Autoreflex-T helps you make superbly detailed negatives easily, even when working under difficult lighting conditions. To facilitate matters there are three separate focusing areas to choose – the center Micro Diaphragm spot (49), the fine ground glass ring surrounding this (50) and the balance of the Viewfinder which is a fine fresnel ground glass.

The Micro Diaphragm consist of thousands of tiny prismatic elements. When the image is out of focus, the Micro Diaphragm spot shows a distinct pattern. This clears up instantaneously the moment sharp focus has been attained. The plain ground glass is useful for subjects that create a moire pattern, such as cloth and other regularly patterned subjects, when focused in the Micro Diaphragm area. The balance of the focusing screen is generally used for composing the picture and when checking Depth-of-Field visually. Illumination of the focusing screen is even, and bright to the corners, with all KONICA lenses.

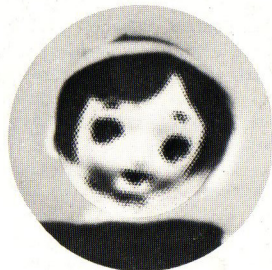

A distinct pattern is seen in the Micro Diaphragm area when the image is out of focus

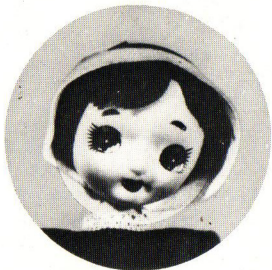

The moment the image is brought into correct focus, the Micro Diaphragm pattern disappears

TAKE ADVANTAGE OF DEPTH-OF-FIELD

Depth-of-Field is the distance between the nearest and farthest objects in the scene that will be sharp in the finished picture. In practical terms this means that when you bring an object into sharp focus, objects behind and in front of this will be rendered more or less sharp too, depending on a series of factors. For more Depth-of-Field, use a small f/stop (larger f/number) and *make the image of the main object smaller by:* (a) moving the camera further away or (b) switching to a shorter focal length lens without changing camera distance. For less Depth-of-Field, use a larger f/stop (smaller f/number) and *make the image of the main object larger by:* (a) moving the camera closer or (b) switching to a longer focal length lens without changing camera distance.

Using Depth-of-Field Scale on Lens:

On the Depth-of-Field Scale, f/stop markings identical to those on the Manual Aperture Scale (8), are repeated to the right and left of the Distance Scale Index Mark (51). The Depth-of-Field for any focused distance will be found between any two identical f/stop markings on the Depth-of-Field Scale. Thus, if the lens is focused at 30 feet and the picture is to be made at f/16, referring to f/16 on both sides of the scale tells us that the Depth-of-Field extends from Infinity to about 13 feet. For maximum Depth-of-Field, including Infinity, set the Infinity mark at the f/stop in use, on the right hand side of the scale.

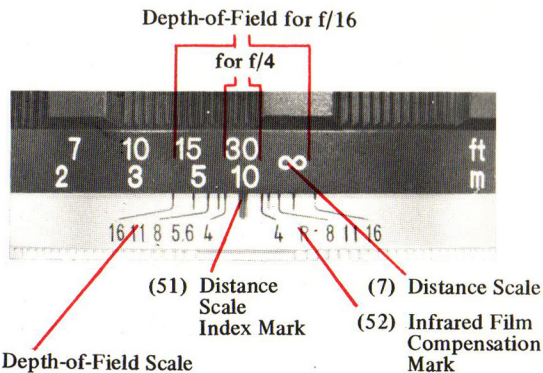

INFRARED FILM COMPENSATION MARK

Infrared rays come to a different focus than visible light rays. When shooting infrared film with the appropriate filter, focus as usual. Then bring the distance figure opposite the Distance Scale Index Mark (51) into line with the Infrared Compensation Mark (52).

FOCAL PLANE MARK

The distances on the Distance Scale (7) are calculated from the Focal Plane Mark "∞" (18) which indicates the position of the film in the camera.

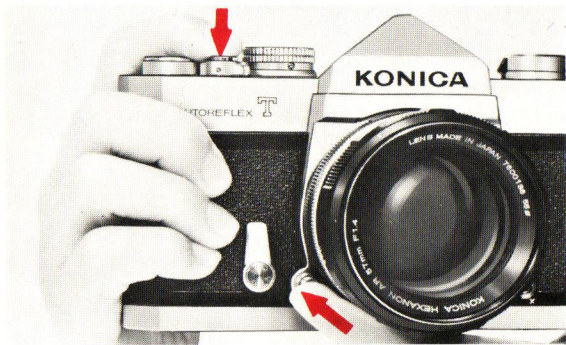

Checking Depth-of-Field Visually:

Visual Depth-of-Field preview is valuable whenever you wish to get an esthetic appreciation of how the finished picture will look when a given *f*/stop is used. To do this, depress the Shutter Release Button (1) partially; thereby locking the meter needle and the diaphragm at the correct aperture. With the forefinger of the left hand, depress the Depth-of-Field Button (37). The lens will then stop down to the aperture at which the meter is set, and you will be able to preview the depth-of-field in the viewfinder. When in non-automatic exposure mode (stopped-down or manual methods), you need not depress the Shutter Release Button, but only the Depth-of-Field Button for previewing depth-of-field.

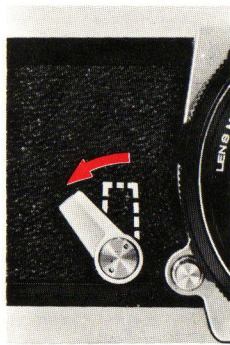

SELF-TIMER

The Self-Timer of the KONICA Autoreflex-T is useful whenever you wish to get into the picture yourself or if the shutter action is to be delayed in order to steady the camera. It may be used for AEC (EE), manual diaphragm, or flash operation. In any case, the amount of time the action of the shutter is delayed amounts to about 10 seconds. To use the Self-Timer, move the Self-Timer Lever (5)

all the way *after* the Film Transport Lever (13) has been advanced. Now depress the Shutter Release Button (1) in the usual manner. The camera should be on a tripod or other support. The Self-Timer Lever will return to its normal position and fire the shutter at the end of its travel.

NOTE: With the camera on a tripod and your eye away from the eyepiece, extraneous light may enter the finder, causing an erroneous exposure setting. It is advisable therefore to temporarily cover the Viewfinder eyepiece against direct light entrance. Also, do not stand directly in front of the lens when releasing the shutter, since then the metering system will be measuring you or your shadow instead of the scene to be photographed. This could lead to incorrect exposure.

You can also use the Self-Timer simply to delay shutter action so that your touching of the Shutter Release Button occurs a few seconds before the picture is snapped. In this case you can set the Self-Timer Lever only part of the way and obtain delays of less than 10 seconds. This method is used when you want both of your hands to hold the camera rock-steady while the Self-Timer trips the shutter.

DEPTH-OF-FIELD TABLES

Permissible Aberrated Circle Diameter
3/100mm (Unit: Feet)

Depth-of-Field Table (57mm f/1.2 · 57mm f/1.4)

Distance Aperture	1.5	1.75	2.0	2.5	3.0	3.5	4.0	5.0	7.0	10.0	15.0	30.0	∞
F 1.2	1.49 1.50	1.74 1.75	1.99 2.00	2.48 2.51	2.97 3.02	3.46 3.53	3.95 4.04	4.92 5.07	6.84 7.16	9.67 10.34	14.26 15.81	27.14 33.54	278.66 ∞
F 1.4	1.49 1.50	1.74 1.75	1.98 2.01	2.48 2.51	2.97 3.02	3.45 3.54	3.94 4.05	4.91 5.09	6.81 7.19	9.62 10.40	14.15 15.96	26.71 34.21	238.90 ∞
F 2	1.49 1.50	1.73 1.76	1.98 2.01	2.47 2.52	2.95 3.04	3.44 3.56	3.92 4.08	4.87 5.13	6.74 7.27	9.47 10.59	13.81 16.41	25.52 36.41	167.32 ∞
F 2.8	1.48 1.51	1.73 1.76	1.97 2.02	2.46 2.53	2.94 3.06	3.41 3.58	3.89 4.11	4.82 5.18	6.64 7.39	9.27 10.85	13.39 17.05	24.09 39.82	119.61 ∞
F 4	1.48 1.51	1.72 1.77	1.96 2.03	2.44 2.55	2.91 3.08	3.38 3.62	3.84 4.16	4.75 5.27	6.50 7.57	8.99 11.26	12.80 18.12	22.22 46.35	83.82 ∞
F 5.6	1.47 1.52	1.71 1.78	1.95 2.04	2.42 2.58	2.88 3.12	3.34 3.77	3.78 4.23	4.66 5.39	6.32 7.83	8.65 11.87	12.10 19.78	20.14 59.37	59.97 ∞
F 8	1.46 1.53	1.70 1.79	1.93 2.06	2.39 2.61	2.84 3.18	3.27 3.85	3.70 4.35	4.53 5.58	6.08 8.26	8.18 12.91	11.18 22.94	17.67 102.87	42.07 ∞
F 11	1.45 1.54	1.68 1.81	1.91 2.09	2.35 2.66	2.78 3.25	3.20 3.86	3.60 4.50	4.37 5.84	5.80 8.87	7.66 14.51	10.22 28.70	15.33 ∞	30.69 ∞
F 16	1.44 1.56	1.66 1.84	1.87 2.14	2.29 2.74	2.69 3.38	3.08 4.06	3.45 4.77	4.14 6.34	5.38 10.12	6.93 18.33	8.94 49.67	12.58 ∞	21.20 ∞

Depth-of-Field Table (52mm f/1.8)

Permissible Aberrated Circle Diameter
3/100mm (Unit: Feet)

Distance Aperture	1.5	1.75	2.0	2.5	3.0	3.5	4.0	5.0	7.0	10.0	15.0	30.0	∞
F 1.8	1.49 1.50	1.73 1.76	1.98 2.01	2.46 2.53	2.95 3.04	3.43 3.56	3.91 4.09	4.86 5.14	6.71 7.30	9.41 10.66	13.70 16.57	25.13 37.22	151.88 ∞
F 2	1.49 1.50	1.73 1.76	1.98 2.01	2.46 2.53	2.95 3.05	3.42 3.57	3.90 4.09	4.84 5.16	6.69 7.33	9.37 10.71	13.60 16.71	24.81 37.97	140.51 ∞
F 2.8	1.48 1.51	1.73 1.77	1.97 2.02	2.45 2.54	2.93 3.07	3.40 3.60	3.87 4.13	4.79 5.22	6.58 7.47	9.14 11.03	13.12 17.52	23.21 41.50	100.46 ∞
F 4	1.48 1.51	1.72 1.77	1.96 2.04	2.43 2.56	2.90 3.10	3.36 3.65	3.81 4.20	4.70 5.33	6.41 7.70	8.82 11.54	12.45 18.88	21.17 51.79	70.41 ∞
F 5.6	1.47 1.52	1.71 1.79	1.94 2.05	2.41 2.59	2.86 3.15	3.31 3.71	3.74 4.29	4.60 5.48	6.21 8.02	8.43 12.31	11.67 21.07	18.95 73.19	50.39 ∞
F 8	1.46 1.53	1.69 1.80	1.92 2.08	2.37 2.64	2.81 3.22	3.23 3.81	3.65 4.42	4.45 5.71	5.93 8.57	7.90 13.69	10.66 25.52	16.39 ∞	35.36 ∞
F 11	1.45 1.55	1.67 1.83	1.89 2.11	2.33 2.70	2.74 3.31	3.14 3.95	3.53 4.61	4.27 6.04	5.61 9.36	7.33 15.92	9.63 34.92	14.03 ∞	25.81 ∞
F 16	1.42 1.58	1.64 1.87	1.85 2.17	2.26 2.80	2.64 3.47	3.01 4.20	3.36 4.97	4.01 6.69	5.15 11.10	6.55 21.93	8.30 ∞	11.33 ∞	17.84 ∞

FILM REWIND

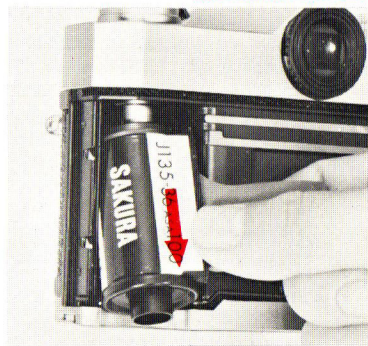
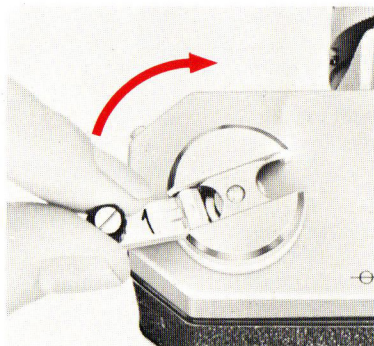
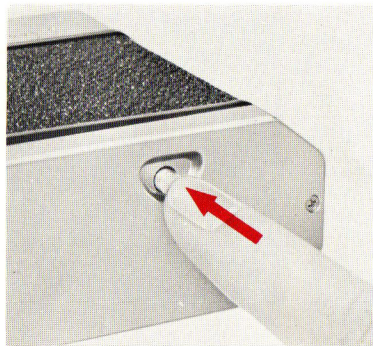

After all the pictures on the roll have been taken, the film must be rewound into the cartridge before opening the camera back. Otherwise the film will be completely exposed and useless.

An occasional look at the Film Counter (2) will help keep you posted as to when you are coming to the end of the roll and prevent your accidentally tearing the film out of the cartridge. If you should come to the end of the film while the camera is at your eye in shooting position, the Film Transport Lever (13) will tighten and refuse to advance even if the shutter has been released. If this happens *do not force it!* Instead, depress the Film Rewind Button (36) and at the same time move the Film Transport Lever as far as it will go. It will then snap back into its normal position.

- 1** Depress the Film Rewind Button (36). Once it is depressed, the button remains in place.
- 2** Raise the Film Rewind Crank (19) and turn it in the direction inscribed on it, turning not too rapidly and in one continuous motion.
- 3** When tension on the Film Rewind Crank eases, the film has been fully rewound. You can now open the camera back and effortlessly remove the cartridge by tipping it towards yourself and letting it drop out of the bottom opening.

The Film Rewind Button returns to its original position once the Film Transport Lever is again actuated.

KONICA
AUTOREFLEX

FILM REWIND

FLASH PHOTOGRAPHY

The all metal Copal Square S focal plane shutter is synchronized for use with flash bulbs and electronic flash. These light sources are useful for making action-stopping photos in dim light. Their high light output makes it possible to produce negatives that have good Depth-of-Field too, and overall sharpness. Flash and electronic flash are also used outdoors to lighten or fill in deep shadows.

Shutter Speed Dial

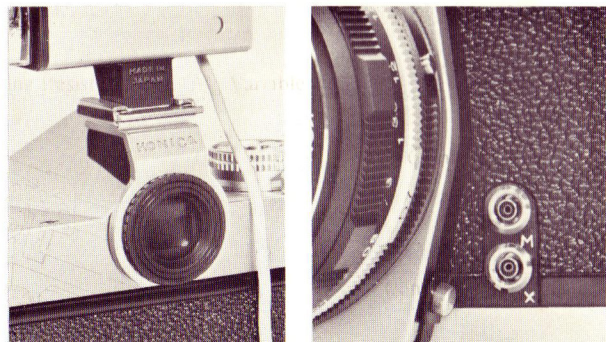

Two standard "PC" flash outlets are provided on the front of the KONICA Autoreflex-T. The upper or "M" outlet, is for use with expendable flash bulbs or flash cubes. The lower, or "X" outlet, is for use with electronic flash.

The "M" Outlet: This is for use with the standard "M" type flash bulbs or focal plane type bulbs or flash cubes. All speeds to 1/1000 may be used. ("M" delay is 18 milliseconds.)

The "X" Outlet: This is for use with electronic flash units. The Copal Square S shutter synchronizes these at all shutter speeds up to 1/125 second. ("X" delay is 0 milliseconds.)

Flash Synchronization for KONICA AUTOREFLEX-T

Contact	Shutter speed												
	Bulb	B	1	2	4	8	15	30	60	125	250	500	1000
M	Class M	○	○	○	○	○	○	○	○	○	○	○	○
	Class FP	○	○	○	○	○	○	○	○	○	○	○	○
	Class MF	○	○	○	○	○	○	○	○	○	○	○	○
X	Strobe	○	○	○	○	○	○	○	○	○	X	X	X

○ – Synchronized X – Not synchronized

exactly that—they can serve as guides but all other existing light will affect your exposures to some extent and you should make allowance in your settings for intermediate f/stops which also click into place.

EXPOSURE FOR FLASH PICTURES

Manual settings are required for flash shooting. The AEC (EE) system is not applicable. Exposures are usually calculated on the basis of “Flash Guide Numbers” furnished by the makers of flash bulbs and electronic flash units. To find the correct f/stop to use, the guide number is divided by the flash-to-subject distance. Thus if the guide number is 110 and the subject is 10 feet away:

$$\frac{110}{10} = f/11$$

If in doubt, refer to the table above as to which shutter speeds are useable with a specific type of flash illumination.

Guide numbers for flash bulbs are generally printed on the package. Electronic flash guide numbers are generally furnished by the maker of the unit. Guide numbers are

TIME EXPOSURES

The “B” setting is used to make exposures longer than 1 second. In use the shutter opens fully when the Shutter Release Button is depressed, and closes instantly when pressure on the button is removed. For very long time exposures the use of a “locking cable release” will be found handy.

Manual diaphragm settings must be made when the Copal Square S shutter is set at “B”. The AEC (EE) setting on the lens is not used. Instead the lens is set manually at the desired f/stop.

It is necessary that you use a tripod or other support for “B” time exposures and all other exposures longer than 1/30 second. Use of a cable release will minimize jarring the camera.

CHANGING LENSES



To Remove the Lens from the Camera:

Depress the Lens Release Button (23), grip the silver portion of the lens barrel, turn lens barrel counterclockwise until the two red dots (one on the camera body and the other on the lens barrel) align. The lens will then come off the camera.

NOTES:

When the lens is removed, do not touch any part of the interior of the camera.

If the lens is to be left off the camera for any length of time, protect the camera interior from dust and moisture by use of a KONICA Body Cap. Where this is not available, keep the camera in a case or dustproof container.



To Mount your Lens on the Camera:

To mount a KONICA lens on the Autoreflex-T, line up the red dot on the lens barrel with the red dot on the camera body. The lens will "seat" into the camera body easily. Then grip the silver part of the lens barrel and turn the lens clockwise until it clicks into place.

HEXANON INTERCHANGEABLE LENSES

KONICA
AUTOREFLEX

HEXANON INTERCHANGEABLE LENSES

mm	Type	Name of Lens	Taking Angle	Lens Construction	Aperture System	Metering	Aperture Scale	Closest Distance	Filter	Hood	Weight
21	Wide-angle	Hexanon AR 21mm f/4	90°	7-group 11-element	Auto	Meter reading at full aperture	EE and f/4-16	8inches	77mm screw-in	80mm clip-on	12ozs
28	Wide-angle	Hexanon AR 28mm f/3.5	75°	7-group 7-element	Auto	Meter reading at full aperture	EE and f/3.5-16	1ft.	55mm screw-in	57mm clip-on	7-1/2ozs
35	Wide-angle	Hexanon AR 35mm f/2.8	63°	5-group 6-element	Auto	Meter reading at full aperture	EE and f/2.8-16	1ft.	55mm screw-in	57mm clip-on	8-1/2ozs
52	Standard	Hexanon AR 52mm f/1.8	42°	5-group 6-element	Auto	Meter reading at full aperture	EE and f/1.8-16	1-1/2ft.	55mm screw-in	55mm screw-in	7-3/4ozs
57	Standard	Hexanon AR 57mm f/1.4	42°	5-group 6-element	Auto	Meter reading at full aperture	EE and f/1.4-16	1-1/2ft.	55mm screw-in	55mm screw-in	10ozs
57	Standard	Hexanon AR 57mm f/1.2	42°	6-group 7-element	Auto	Meter reading at full aperture	EE and f/1.2-16	1-1/2ft.	62mm screw-in	62mm screw-in	17ozs
85	Telephoto	Hexanon AR 85mm f/1.8	28.5°	5-group 6-element	Auto	Meter reading at full aperture	EE and f/1.8-16	3ft.	55mm screw-in	55mm screw-in	14ozs
100	Telephoto	Hexanon AR 100mm f/2.8	24°	4-group 5-element	Auto	Meter reading at full aperture	EE and f/2.8-16	3ft.	55mm screw-in	55mm screw-in	10ozs
135	Telephoto	Hexanon AR 135mm f/3.2	18°	4-group 5-element	Auto	Meter reading at full aperture	EE and f/3.2-16	3ft.	55mm screw-in	pull-out	13-3/4ozs

HEXANON INTERCHANGEABLE LENSES

mm	Type	Name of Lens	Taking Angle	Lens Construction	Aperture System	Metering	Aperture Scale	Closest Distance	Filter	Hood	Weight
200	Telephoto	Hexanon AR 200mm f/3.5	12°	4-group 5-element	Auto	Meter reading at full aperture	EE and f/3.5-16	8ft.	67mm screw-in	pull-out	31ozs
200	Telephoto	Hexanon ARP 200mm f/5.6	12°	4-group 6-element	Preset	Meter reading at stopped-down aperture	f/5.6-22	8ft.	46mm screw-in	pull-out	12ozs
300	Telephoto	Hexanon AR 300mm f/4.5	8°	5-group 8-element	Auto	Meter reading at full aperture	EE and f/4.5-16	13ft.	72mm screw-in	pull-out	34ozs
400	Telephoto	Hexanon ARM 400mm f/4.5	6°	4-group 4-element	Manual	Meter reading at stopped-down aperture	f/4.5-32	25ft.	55mm behind-lens	pull-out	5lbs5ozs
800	Telephoto	Hexanon ARM 800mm f/8	3°	1-group 2-element	Manual	Meter reading at stopped-down aperture	f/8-45	65ft.	55mm behind-lens	pull-out	12lbs6ozs
1000	Reflex Telephoto	Reflex Hexanon ARM 1000mm f/8	2.5°	6-group 7-element	ND Filters	Meter reading at stopped-down aperture	f/8-22	80ft.	55mm behind-lens	—	18lbs12ozs
80-200	Zoom	Zoom Hexanon AR 80-200mm f/3.5	30-12°	10-group 17-element	Auto	Meter reading at full aperture	EE and f/3.5-16	6ft.	67mm screw-in	67mm screw-in	2lbs10ozs
55	Macro	Macro Hexanon AR 55mm f/3.5	43°	3-group 4-element	Auto	Meter reading at full aperture	EE and f/3.5-22	10inches	55mm screw-in	—	10ozs

FILTERS

• KONICA Filters

KONICA Filters help make more natural looking pictures in black and white or color. They may also be used to create special effects. They are made with the same precision as are Hexanon lenses. Since exposure is read through the lens in the Autoreflex-T, the filter factor for KONICA Filters is taken care of automatically.

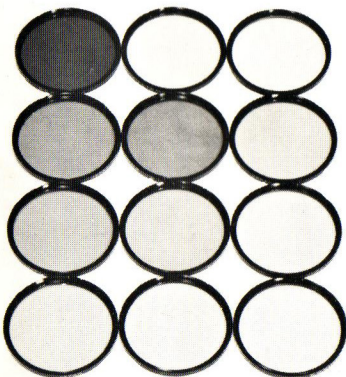

COLOR	NAME	EFFECTS
Colorless*	UV (L39)	Absorbs ultra-violet. Prevents excess bluishness with color film. No change in the overall color rendition. Also used for atmospheric haze.
Light Yellow Yellow Dark Yellow	Y1 (Y44) Y2 (Y48) Y3 (Y52)	Absorbs blue, violet and ultra-violet. Gives natural rendition in outdoor black and white shooting. Makes white clouds stand out against a blue sky. For use with B/W films only.
Orange	O1 (O56)	Absorbs blue very strongly, also some green. Makes blue skies dark and dramatic in black and white. For extra contrast in architectural work. For use with B/W films only.
Red	R1 (R60)	Absorbs blue and green. Blue skies rendered almost black. Use for pseudo night shots. Use only for black and white film, or for infrared film.
Yellowish Green	PO 0	In black and white photography, renders greens better than yellow filter. Also prevents washed-out flesh tones when head is against sky which is to be darkened. For use with B/W films only.
Light Gray Gray Dark Gray	ND 2 ND 4 ND 8	No effect on rendition in either black and white or color work. Used to reduce light intensity, where highest shutter speed or smallest f/stop used, will still not prevent overexposure. In very bright light permits large opening for selective focus effect.
Light Pink*	SKYLIGHT	For color and B/W film. Absorbs ultra-violet and prevents excess bluishness in color shots of distant scenes. Can also be used with B/W film.
Light Amber	A 2	Reduces color temperature. Adds warmth to shadows in snow, beach scenes. Prevents bluishness on cloudy days, in open shade.
Light Blue	B 2	Raises color temperature. Suppresses excess redishness in scenes made by reddish early morning or late afternoon sunshine.
Blue	B 8	For use with clear (white) flash bulbs and daylight type color film. Prevents excessively reddish rendition.
Dark Blue	B 12	For use with 3200K studio flood lamps and daylight type color film. Prevents reddish rendition.

* Filters most commonly used in color photography are marked with an asterisk * above.

KONICA
AUTOREFLEX

ACCESSORIES

• Lens Hoods

Prevent stray light from striking lens surfaces and causing unwanted reflections. Each KONICA Lens Hood is specifically calculated and shaped to give maximum protection to the lens on which it is used.

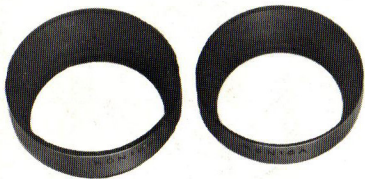

• Cube Flash

With PC cord (for Autoreflex-T) and hot shoe contact. Built-in test circuit with indicator light that shows when cube is ready to fire. With exposure guide table and case.



KONICA LENS MOUNT ADAPTERS

• KONICA Adapter

Permits use of KONICA F, FS, FP, FM lenses with "match-needle" exposure automation.

• Exakta Adapter 2

Permits use of Exakta lenses with "match-needle" exposure automation.

• Praktica Adapter 2

Permits use of Pentax/Praktica lenses with "match-needle" exposure automation.

• Nikon Adapter

Permits use of Nikon lenses with "match-needle" exposure automation.

• Close-Up Attachment-Lens 55 ϕ

The No. 1 permits close-ups in a range from 25" to 12½"; the No. 2 from 14" to 11". Both may be combined for a range of 11½" to 9". They screw into the lens like a filter. For use with normal lenses. No change in exposure is necessary.

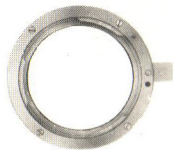

• **Accessory Clip 3**

Fits over the eyepiece of the KONICA Autoreflex-T. Useful for mounting small flash or electronic flash units.



• **Extension Ring 2**

Used to extend the close focusing range of Hexanon lenses. Inserted between lens and camera. A full set enables making 1:1 or life size pictures using a normal lens.

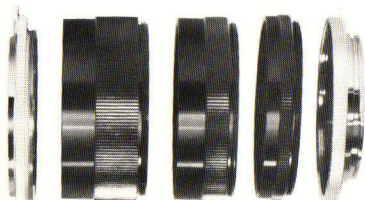

• **Extension Bellows 2**

Used for the same purposes as extension rings. However, bellows are more flexible since extension is continuously variable instead of in fixed sections. Larger image size possible than with ring set.

• **Extension Bellows 2 and Slide Copier**

A deluxe version of the Extension Bellows 2.

Permits changing position of camera body on track, in addition to having lens movement. Slide copier is fitted to end of the lens in use, forms light-tight, integral unit.

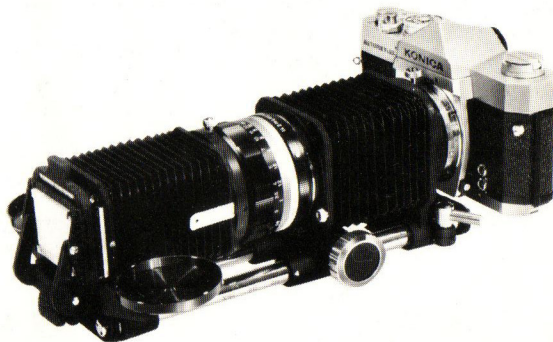

ACCESSORIES

- **Auto Ring and Double Cable Release**

When Hexanon AR (Electric-Eye) lenses are used with extension tubes or bellows, the Auto Ring plus the Double Cable Release provide semi-automatic diaphragm operation and permit "wide open" viewing and focusing. The Auto Ring contains the diaphragm stop-down actuating mechanism. The Double Cable Release is connected to the Auto Ring and the Shutter Release. Pressure on the plunger releases the diaphragm, then the shutter, in proper sequence.

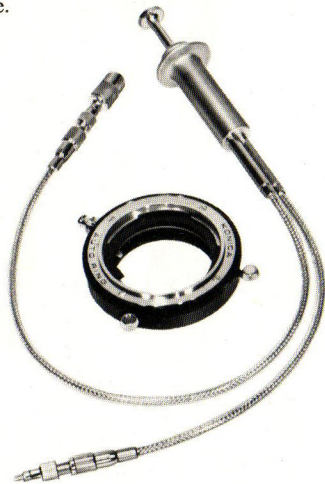

- **Eyesight Correction Lenses**

Eyesight correction lenses make it possible for near or far-sighted persons to see the focusing screen clearly without wearing glasses. They are available in +1, +2, +3 and -2.5 diopters. They screw directly into the Viewfinder eyepiece.



- **KONICA Cable Release**

Use of a KONICA Cable Release when the camera is mounted on a tripod or other support helps make rock-steady exposures even at very slow shutter speeds.



- **Angle Finder 2**

The Angle Finder is useful for low angle photography, for "sneak" shots with the camera held sideways, and for convenient viewing and focusing when the KONICA Autoreflex-T is mounted high on a tripod or on a copying stand.

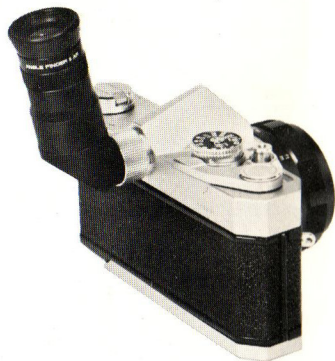

● **Microscope Adapter 2**

The Microscope Adapter makes direct, light-tight connection between the KONICA Autoreflex-T and the microscope. The camera lens is not used, and the picture is made with the microscope optics.



● **Copying Stand**

The baseboard of the Copying Stand accepts flat originals up to 10-5/8" X 13-3/4". It provides a steady support, adjustable in height for copying, slide duplicating and small object photography.



For a more detailed description of lenses and accessories see your KONICA dealer or write for booklet on lenses and accessories. Specifications subject to change without notice.

KONISHIROKU PHOTO IND. CO., LTD. — Tokyo, Japan

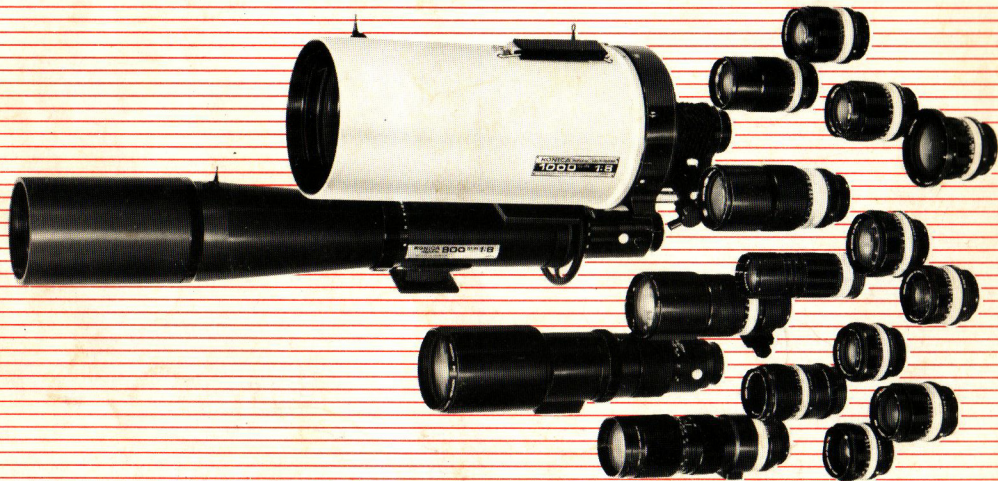

A DIVISION OF
Berkey
Photo Inc. 

KONICA CAMERA CORP.
NEW YORK — LOS ANGELES

2-71 PRINTED IN JAPAN