

WILSONWERKS ARCHIVES

This camera manual is for reference and historical purposes, all rights reserved.

This cover page is copyrighted material. This document may not be sold or distributed without the express consent of the publisher.

©2008 wilsonwerks Llc

PENTAX®

SMC PENTAX-FA INTERCHANGEABLE LENSES OPERATING MANUAL



Congratulations on purchasing the Pentax SMC lens. This booklet contains all the instructions you need to make the most out of your SMC Pentax-FA lenses. So always keep it handy and whenever you have questions about the handling and care of your lens, read it very carefully, together with your camera's Operating Manual.

- See the Operating Manual of each Pentax camera.
- For the purpose of this Operating Manual, FA lens is referred to as the SMC Pentax FA lens.
- The lens listed in color on some pages are SMC Pentax F lens.

CONTENTS

◦ LENS MAINTENANCE	1	◦ MACRO LENS	20
◦ SMC PENTAX F and FA LENSES	2	•Magnification	
•Mount compatibility		•Clamp screw	
◦ LENS INTERCHANGING	4	•Focus range limiter	
◦ FOCUSING	5	◦ TELEPHOTO LENS(FA* 85mm f/1.4 (IF), FA* 200mm f/2.8ED(IF), FA* 300mm f/4.5ED(IF))	24
◦ APERTURE CONTROL	6	•Note on ∞ (infinity) mark	
◦ HOW TO USE INFRARED INDEX	8	◦ WIDE-ANGLE LENS(FA* 24mm f/2 AL (IF))	26
◦ LENS HOOD	9	◦ Special lens hood	28
•Square lens hood		◦ TABLE OF SMC PENTAX F and FA LENSES	30
•Round-type lens hood		◦ LENS SOFT CASE	32
•Built-in lens hood		◦ WARRANTY POLICY	32
◦ FILTER	12		
◦ BUILT-IN FLASH	13		
◦ ZOOM LENS	14		
•Power zoom ring			
•Aperture			
•Infrared index of the zoom lens			

LENS MAINTENANCE

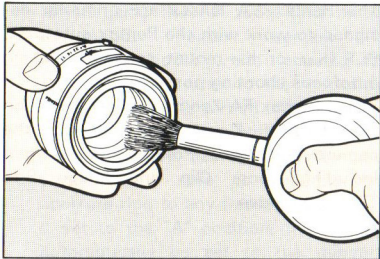

- When storing the lens in a case, attach the front and rear lens caps that come supplied with the lens to protect it from dust and scratches.
- After removing the lens from the camera body, be careful not to let it roll over or fall. Be sure to place the lens with its front side down.
- Moisture can cause serious damage to optical glass elements—the nucleus of your lens. Storage in a damp place may

cause mildew, so avoid storing the lens in a place where temperature and humidity are high. Keep your lens in as dry a place as possible.

- If you do not expect to use the lens for an extended period, store it in the case with a desiccant or it is recommended that the lens occasionally be taken out of the case and placed in a cool, dry, well-ventilated place to avoid the possibility of damage due to condensation build-up.
- Use a blower or lens brush to remove dust or fingerprints collected on the lens. If the lens becomes dirty, remove the dirty particle with a blower brush, then wipe it off with a clean cotton cloth or tissue paper moistened with lens cleaning solution. Wipe in a spiral pattern from the center to the outside.

SMC PENTAX F and FA LENSES

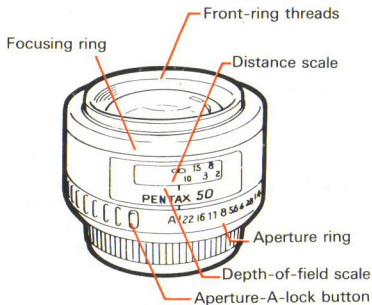

The Pentax FA lenses are primarily designed to work with the Pentax autofocus SLR (KAF2-or KAF-mount camera), making autofocus shooting possible.

When Pentax FA Zoom lenses are used on the Pentax KAF2-mount camera, the camera features a Power Zoom system including Zoom Clip and Image Size Tracking modes.

KAF-mount

KAF2-mount

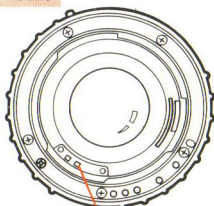
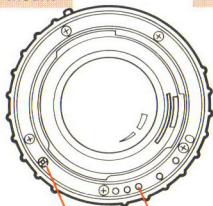

※The FA zoom lenses have power contacts on their mount sides.

Do not damage or dirty the power contacts.

- When using the FA zoom lens on the K_{AF2}-mount Pentax camera for autofocus shooting, the focusing ring automatically returns to the ∞ position after the power is turned off.
- When using FA lens with the K-mount Pentax camera having no information contacts, be sure to set the lens aperture ring to any f-stop other than A. If set to the "A" position, the lens will automatically be set to the minimum aperture, causing improper exposure.

CAUTION:

Be careful not to damage or dirty the lens information contacts and AF coupler on the mount surfaces of the camera and lens. Otherwise, failure or malfunction may result. If this occurs, wipe them gently with a clean, dry cloth.

Camera/Lens Mount Compatibility

Pentax camera/lens mount compatibility chart is shown below.

<p>K_{AF2}-mount (Z-1/PZ-1, Z-10/PZ-10, Z-20/PZ-20)</p> <p>which is equipped with</p> <ul style="list-style-type: none"> ◦ Power contacts ◦ AF coupler ◦ Lens information contacts
<p>K_{AF}-mount (SF_{XN}/SF_{1N}, SF7/SF10)</p> <p>which is equipped with</p> <ul style="list-style-type: none"> ◦ AF coupler ◦ Lens information contacts
<p>K_A-mount (P30_N/P3_N/P30_T)</p> <p>which is equipped with</p> <ul style="list-style-type: none"> ◦ Lens information contacts
<p>K-mount (LX, K1 000) (base mount)-</p> <p>-will not autofocus, autozoom or provide automatic electronically controlled aperture settings.</p>

LENS ATTACHMENT AND REMOVAL

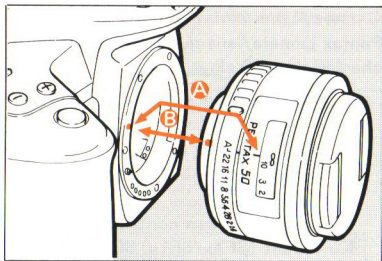

1. To mount the lens on the camera, line up the red indexes on the lens and camera (see **A** and **B**) and turn the lens clockwise until the lens seats with a click. When mounting a larger telephoto lens or zoom lens, mount carefully by holding it firmly.

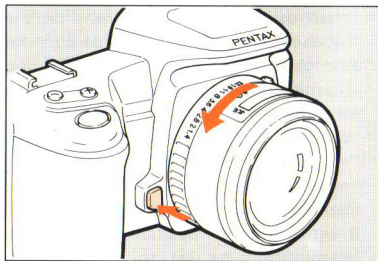

2. To remove the lens, turn the lens counterclockwise while pressing the lens-release button on the camera body.

FOCUSING

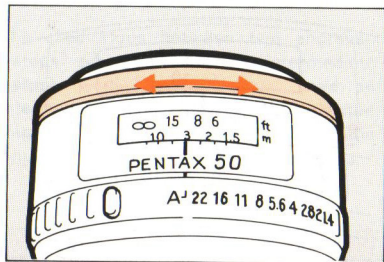
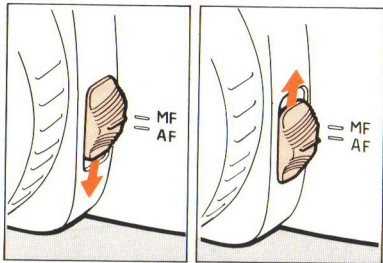

To set the autofocus mode on your KAF2- or KAF-mount camera, slide the focus lever to the autofocus position. See the Operating Manual of your camera.

- During autofocus, do not touch the focusing ring of your lens or you will interfere with proper lens movement.

To set the manual focus mode, slide the focus lever on your camera to the manual focus position. In the MANUAL focus mode, you can focus the lens by turning

the focusing ring and confirming the FI signals [] through the viewfinder.

- When using FA lens with the non-KAF2- or KAF- mount camera body, focus the lens by turning the focusing ring.

APERTURE CONTROL

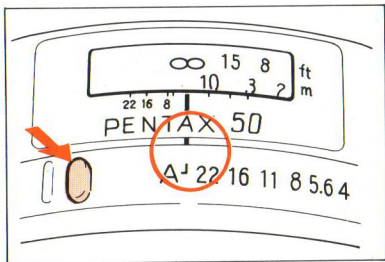

To set the aperture to "A" (Auto), align the aperture-A index with the white-bar index while pushing the aperture-A lock button. To switch the aperture to any other f-stop, turn the aperture ring to the left while pushing the aperture-A lock button.

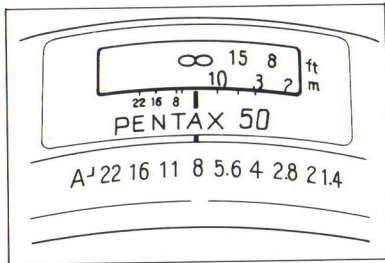

- When using the Z-1/PZ-1 and Z-20/PZ-20, the approximate aperture value will be displayed on the LCD panel and in the viewfinder if the shutter release button is pressed halfway down with the lens aperture ring set to a position other than A.
- When using a K-mount camera having no lens information contact, set the lens aperture ring to a position other than A (auto).

F-STOPS OR F-NUMBERS AND CLICK STOPS

There is a white dot next to the maximum f-number engraved on the lens's aperture ring on many Pentax lenses. This white dot indicates an aperture which is darker than by one stop (larger number). The illustration below shows the white dot next to $f/4.5$ is $f/5.6$

The click stops between two engraved f-stops are equivalent to intermediate f-stops. Some lenses do not have an intermediate click f-stop on the aperture ring due to limited space between the f-numbers engraved on the aperture ring.

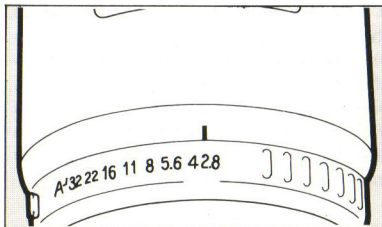
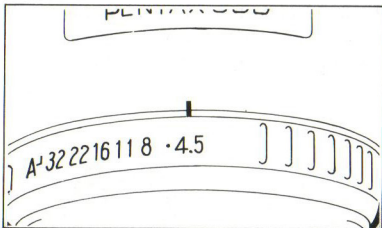
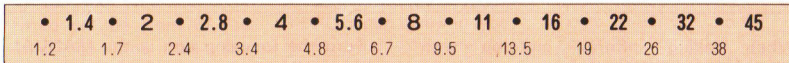

HOW TO USE THE INFRARED INDEX

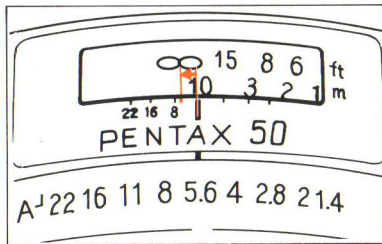
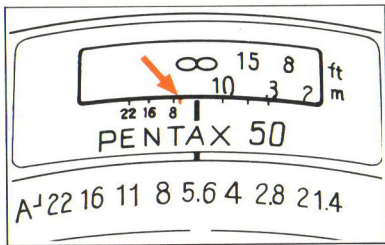

When taking infrared pictures with infrared film and either a "R2" or "O2" filter, it is necessary to adjust the focus because the point of focus is not the same with infrared light as it is with visible light. As shown above, memorize the focusing point on the lens distance scale when viewed through the viewfinder and turn the focusing ring until the point you memorized aligns with the infrared index.

- Turn the focusing ring in the MANUAL focus mode only.
- For the exposure control required in this special photography, see the information supplied with the infrared film.

LENS HOOD

Pentax lens hoods come in round and square shapes. And some are built into the lens. Make sure to use a proper size lens hood specially designed for your lens.

Note:

When the lens hood is fitted on the front of the lens, do not use the built-in flash on your K_{AF2}- or K_{AF}-mount camera, as it may obstruct the path of the light coming from the flash, causing vignetting in the picture comers.



Square Hoods

49mm spring-type(PH)

49mm spring-type(PH)

Round Hoods

49mm screw-in-type(PH)

49mm screw-in-type(RH)

RH-RA 49mm screw-in-type

RH-RB 49mm screw-in-type

RH-RA 52mm screw-in-type

RH-A 58mm screw-in-type

RH-RC 58mm screw-in-type

RH-RC 58mm screw-in-type

MH-RA112 screw-in-type

Bayonet-type

PH-RBA67

MH-RBB67

MH-RBA77

MH-RBA67

PH-RBC 77

Lens

28mm f/2.8

50mm f/1.4 & f/1.7

Lens

50mm f/1.4 & f/1.7

50mm f/1.4 & f/1.7

Zoom 35-80mm f/4-5.6

Zoom 70-200mm f/4-5.6

Zoom 80-200mm f/4.7-5.6

Macro 50mm f/2.8

Zoom 100-300mm f/4.5-5.6

Zoom 28-80mm f/3.5-4.7

Zoom 28-105mm f/4-5.6

FA ★ 300mm f/2.8ED(IF)

FA ★ 24mm f/2AL(IF)

FA ★ 85mm f/1.4(IF)

FA ★ 200mm f/2.8ED(IF)

FA ★ 300mm f/4.5ED(IF)

Zoom 28-70mm f/2.8AL

Zoom 80-200mm f/2.8ED(IF)

PH=Plastic Hood : RH = Rubber Hood :
MH= Metal Hood

How to Use the Square Hood

1. Attach the square hood to the front of the lens while pressing the knurled tabs on both sides of the hood.

2. Make sure to keep the top and bottom of the hood parallel with the top and bottom covers of the camera. The improper fitting will cause the vignetting in the picture corners.

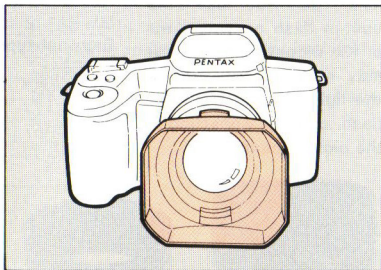
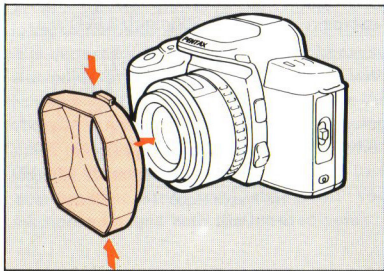

How to Use the Round Hood

The round hood screws into the front of the lens.

- The lens hood for 24mm f/2.8, 200mm f/2.8 and 300mm f/4.5 comes in bayonet type (see pages 28 and 29.)
- The round type rubber hood can be folded when not in use.
- For F Zoom 80–200mm lens, it is advisable to attach the hood to avoid internal reflections.

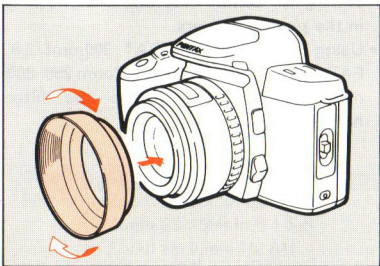

- However, when the hood is in use for any lenses, do not use the built-in flash on your camera because the flash light is blocked by the hood.

How to Use the Built-in Hood

To use a lens with a built-in hood, first extend the hood to the fullest position. The 600mm f/4 lens and 250-600mm f/5.6 zoom lenses come in screw-fixed-type. Extend these hoods while rotating them for use. See the lens instruction manual for details.

Lenses with Built-in Hoods

FA 135mm f/2.8(IF)

FA* 600mm f/4 ED(IF)

FA* Zoom 250-600mm f/5.6 ED(IF)

- * The built-in flash of the KAF2-OR KAF-mount camera can be used when the built-in hood is utilized on the FA 135 mm f/2.8 lens.

Screw-in Type Filters

This type of filter screws into the front of the lens. Make sure to use the proper size Pentax filter specially designed for your lens.

Size	Lenses
49mm	28mm f/2.8 50mm f/1.4, 50mm f/1.7 Zoom 70-200mm f/4-5.6 Zoom 35-80mm f/4-5.6 Zoom 80-200mm f/4.7-5.6
52mm	135mm f/2.8 (IF) Macro 50mm f/2.8 (IF)
58mm	Zoom 28-80mm f/3.5-4.7 Zoom 28-105mm f/4-5.6 Zoom 100-300mm f/4.5-5.6 Macro 100mm f/2.8
67mm	FA★ 24mm f/2 (IF) FA★ 85mm f/1.4 (IF) FA★ 300mm f/4.5 ED (IF) Zoom 28-70mm f/2.8AL
77mm	FA★ 200mm f/2.8 ED (IF) Zoom 80-200mm f/2.8ED(IF)

Precautions on Filters

- A filter, when attached to your lens, becomes part of the optical system. Handle it as carefully as you do the lens. Avoid using two filters in combination, with the exception of the polarizing filters, as a deterioration in image quality may result.
- Using a filter on the FA Zoom 28-80mm or FA Zoom 28-105 mm lens at close shooting distance with the focal length setting of 28mm may cause vignetting in the picture corners.
- Using a filter on the FA★ 300mmf/2.8, FA★ 600 mmf / 4 and FA★ Zoom 250-600 mm lenses, screw it into the filter holder.

Circular Polarizing Filter and Vignetting

When attaching the polarizing filter on K_{AF2}- or K_{AF}- mount camera, be sure to use the circular type alone. The circular type polarizing filter consists of two glass elements, and is thicker than an ordinary filter. For this reason, using the circular type on the lenses as shown on the table below may cause vignetting in the picture corners.

With the built-in flash in popped-up position, the flash can be used if no warning indication appears when the shutter release button is pressed halfway down. However, some lenses cause vignetting in the picture corners, even though warning indication does not appear; some do not, though the warning indication appears. For more on this, see the camera operating manual.

Size	Lens
58mm	Zoom 28-80mm f/3.5-4.7 Zoom 28-105mm f/4-5.6 Zoom 28-70mm f/2.8AL

ZOOM LENS

* For FA* Zoom 80-200mm
and FA* Zoom 250-600
mm lens, refer to their
own manual, too.

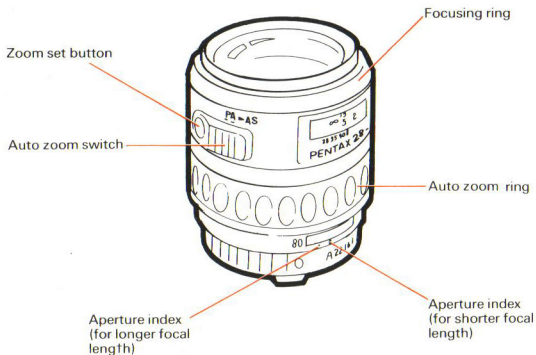

Pentax FA zoom lens is “two-touch” type ; it has separate focusing and zooming rings.

Set the desired focal length by turning the power zoom ring. Changing the focal length by turning the power zoom ring means that the focusing point may shift slightly. After zooming to your desired focal length, make sure the image is in focus by using the autofocus indication (Focus Indicator) in the viewfinder before releasing the shutter.

Note on “Tulip mark (🌷)”

A zoom lens that enable to take a picture at closed shooting distance such as a fixed focal length lens, even set at a wide-angle position, provides with the “Tulip mark (🌷)” on the focusing ring. In the range of the tulip mark at a wide-angle setting, picture corners may be darkened due to reduced brightness of the edge of image field.

When combined with K_{AF2}-mount cameras, FA Zoom lens features the following capabilities.

- (1)Image Size Tracking
- (2)Zoom Clip
- (3)Zoom Effect(Z-1/PZ-1 and Z-20/PZ-20)

The Auto Zoom switch and Zoom Set button are used to select and set the Auto Zoom function : the Auto Zoom switch has following three positions :

- P (Power Zoom) = Set to this position when using the Power Zoom function.
- A (Auto Zoom) = Set to this position when using the Auto Zoom function.
- AS (Auto Zoom Set) = Set to this position when selecting the type of Auto Zoom function.

- When the FA zoom lens is used on the K_{AF2}-mount Pentax camera, the following functions work when the main switch is turned off.

(1) When the lens is used as power zoom, the lens will automatically zoom to the focal length setting at which the lens's length becomes smallest.

(2) When the autofocus function is in use, the focusing ring will move to the ∞ position.

- Some FA zoom lenses, the letters indicating the three functions for Auto zoom switch have been changed as follows. But their usages and functions unchanged.

P → PZ

A → AZ

AS → MODE

When combined with non-K_{AF2}-mount cameras, FA Zoom lens features the following capability.

- As the Power Zoom function does not work, set the manual zoom mode. Pull the zoom ring towards the camera side until the words "POWER ZOOM" disappears to set the manual zoom mode.

* When using non-K_{AF2}-mount cameras, the Auto Zoom switch and Zoom Set button do not work.

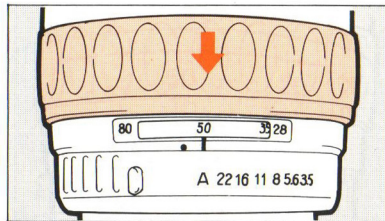
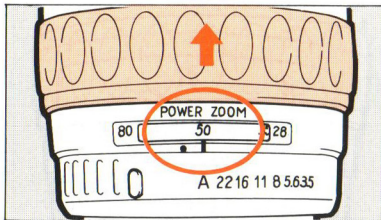

POWER ZOOM RING

To use the lens as a power zoom when mounted on the K_{AF2}-mount camera, push the power zoom ring forward until the words "POWER ZOOM" appear beneath the power zoom ring.

To set the focal length manually by turning the power zoom ring, pull the power zoom ring towards you to get out of the "POWER ZOOM" position.

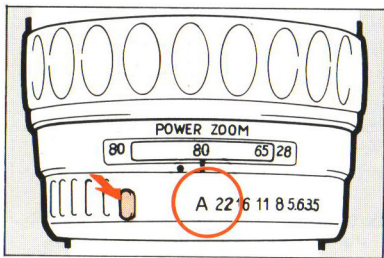

Aperture

To set the aperture of the zoom lens, align the aperture-A index with the white-bar index. The dot on the left-hand side of the white-bar index serves as an index to align an f-stop other than A when shooting at a longer focal length.

For example, when using the Zoom 28-80 mm lens and wishing to set the aperture to $f/8$ with the focal length at 80 mm, align "8" on the aperture ring with this dot.

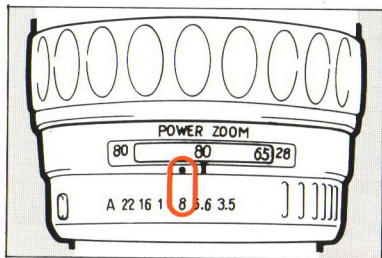

- To set the aperture to A (Auto) , align the aperture-A index with the white-bar index, regardless of focal length selected.

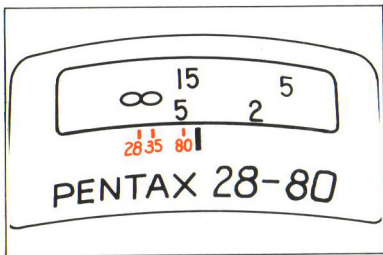

Infrared Index of the Zoom Lens

When taking infrared photographs with the zoom lens, compensation in focus is necessary depending upon the focal length. As shown in the figure, the distance scale of the zoom lens has infrared indexes for each focal length. Compensate for the focus according to the focal length in use (see page 8.) .

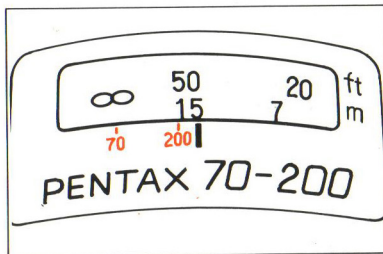

With lenses having indexes only for the longest and shortest focal length, such as FA Zoom 70-200mm, obtain the compensation value for intermediate focal length by using the scale as a guide.

MACRO LENS

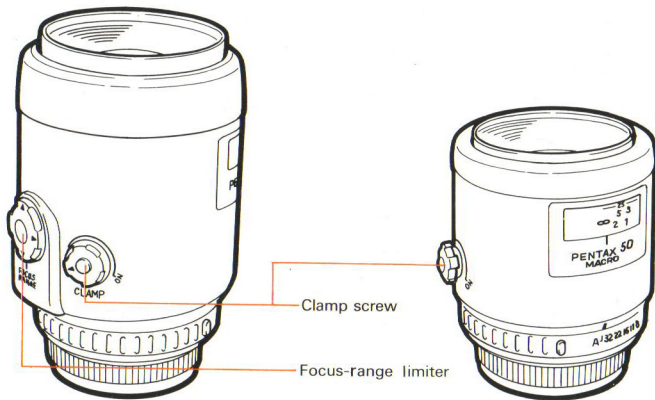

Pentax 50mm f/2.8 and 100mm f/2.8 FA Macro lenses focus from infinity down to life size (1X) . The FA 100mm f/2.8 lens is equipped with focus range limiter. You can control the focusing range by using the focus range limiter ; it has an approx. 0.57 m (1/4X) to 0.31 m (1X) focusing range on the close-distance side ; from infinity to approx. 0.63m on the long-distance side. Make the best use of this convenient range limiter according to the camera-to-subject distance.

- * When the focus-range limiter is set to the "MANUAL" position, you can focus the lens manually.

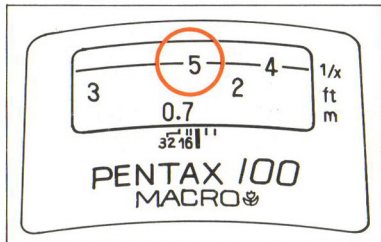

Magnification Scale

The magnification is indicated by denominators on the distance scale. "5" indicates "1/5X" . When determining the magnification first, set the magnification in the MANUAL focus mode and adjust the position of the camera by moving the camera closer or further from the subject.

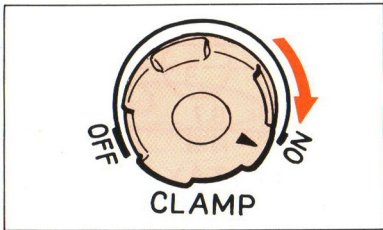

Clamp Screw

FA Macro 50mm and 100mm lenses are equipped with a clamp screw that is used when focusing manually. With manual close-up photography using the copy stand in any situation or with the lens pointing down, if you turn the clamp screw to the ON position, rotation of the focusing ring becomes tight. This helps to prevent the rotation of the focusing ring due to the lens's own weight and avoid any shift in focus.

- When shooting in the autofocus mode, turn the clamp screw to the OFF position. Activating the autofocus mode while the clamp screw is in the ON position slows down the focusing speed. For normal use, turn the clamp screw to the OFF position.

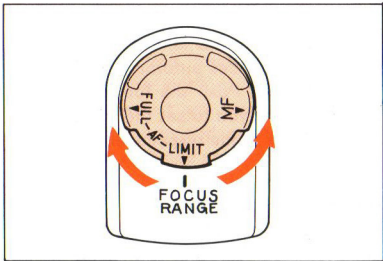

Focus-Range Limiter

When you set the knob on the focus-range limiter at "LIMIT" with the distance scale set at ∞ , the focus range is set to the long distance side (normal photography), and when you do the same with the distance scale set at the minimum focus distance, the focus range is set to the close-distance side (macro shooting).

To clear the setting of the focus-range limiter, set the knob to "FULL".

- When the magnification scale is set near 4 (1/4X), the focus range limiter knob may not turn.
- With the K_{AF2}-mount camera, when the focus-range limiter is set at MANUAL (MF position), manual focus is possible even if the autofocus mode is set on the camera.
- With the K_{AF2}-mount camera, when the focus-range limiter is set at MANUAL (MF position), the shutter cannot be released unless the focus indication appears in the viewfinder, if the camera is set to the autofocus mode (AF single mode).
- When these macro lenses are used on the K_{AF}-mount camera, the built-in flash does not fire.

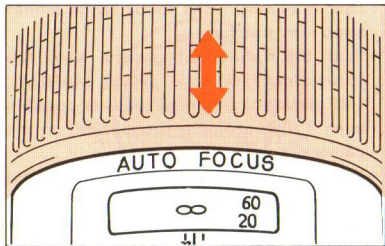

FA* 300 mm f / 4.5 lens has a focusing ring which provides autofocus and manual focus settings. Push the focusing ring or pull it towards you to set the autofocus or manual focus mode respectively.

When used on the K_{AF2}-mount camera, manual focus mode is set by setting the manual mode on the lens even if the autofocus mode is set on the camera.

- * The illustration depicts the 300 mm f / 4.5 lens : when using the 85mm f/1.4 and 200 mm f / 2.8 , the operation is similar to that of the 300mm f/4.5.
- * For FA* 300mm f/2.8 and FA* 600mm f/4 lenses, refer to their own manual, too.

When the lens is set to manual focus position and the focusing ring is fully rotated to the right or left to manually focus the lens, it will keep rotating as no stoppers are provided at the ∞ (infinity) or shortest distance positions.

- When the focusing ring on the lens is set to the autofocus position, the focusing ring is locked.
- When used on the K_{AF}-mount camera, set the same focus mode on the camera and lens. When the camera is set to the autofocus mode (AF single) and the lens to manual focus mode, the shutter cannot be released unless the focus indication appears in the viewfinder.

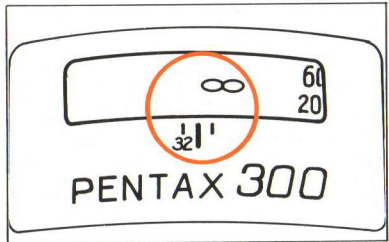

Note on ∞ (infinity) Mark except the 85 mm f/1.4 lens

The focusing ring of the telephoto lens stops slightly past the ∞ mark. This is because temperature change causes the focusing point to shift, making the lens focus on a point past the ∞ mark. Even when shooting at infinity, be sure the image is in focus utilizing the focus indicator before releasing the shutter.

WIDE-ANGLE LENS (FA* 24mmf/2(IF))

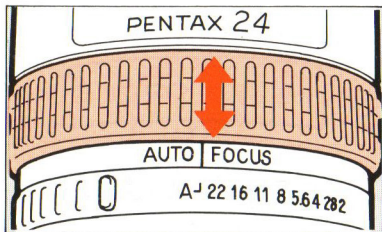

FA* 24mm f/2 lens has a focusing ring which provides autofocus and manual focus settings. Push the focusing ring or pull it towards you to set the autofocus or manual focus mode respectively.

When used on the K_{AF2}-mount camera, the manual focus mode is set by setting the manual mode on the lens even if the autofocus mode is set on the camera.

- When the lens is set to manual focus position and the focusing ring is fully rotated to the right or left to manually focus the lens, it will keep rotating as no stoppers are provided at the ∞ or shortest distance positions.
- When the focusing ring on the lens is set to the autofocus position, the focusing ring is released, allowing a full 360° rotation and providing a click stop at each 30° turn.
- When used on the K_{AF}-mount camera, set the same focus mode on the camera and lens. When the camera is set to the autofocus mode (AF single) and the lens to the manual mode, the shutter cannot be released unless the focus indication appears in the viewfinder.
- When used on the non-K_{AF2}- or K_{AF}-mount camera, focus the lens with the focusing ring.

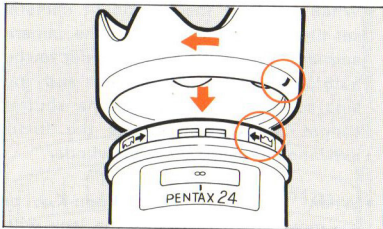

Special lens Hood

- The lens hood for the 24mm f/2 lens comes in bayonet type (PH-RBA67). To attach the hood to the lens, align the hood and the lens front, then turn the hood clockwise to lock it in place. To remove it, reverse the above procedure.
- When the hood is not in use, fit it over the lens in the reverse position. Turn the hood to the left to lock it in place.

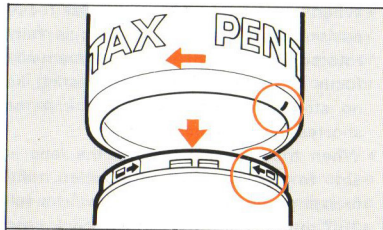

Special Lens Hood

- The lens hood for the 300mm f/4.5 lens comes in bayonet type (MH-RBA 67). The installation and removal procedures are similar to that of 24mm f/2 lens.
- When the hood is not in use, fit it over the lens in the reverse position. Turn the hood to the left to lock it in place.
- Always attach the hood to avoid internal reflections.

- The lens hood for the 85mm f/1.4 lens comes in bayonet type (MH-RBB67). To attach the hood to the lens, align the hood and lens front, turn the hood clockwise to lock it in place. To remove it, reverse the above procedure.
 - Except when using the built-in flash, always attach the hood to avoid internal reflections.
 - When the hood is not in use, fit it over the lens in the reverse position. Turn the hood clockwise to lock it in place.
- The lens hood for the 200mm f/2.8 or Zoom 28–70mm lens comes in bayonet type (MH-RBA77 for the 200mm f/2.8, PH-RBC77 for the Zoom 28–70mm) .
To attach the hood to the lens, align the hood and lens front, turn the hood clockwise to lock it in place. To remove it, reverse the above procedure.
 - Except when using the built-in flash, always attach the hood to avoid internal reflections.
 - When the hood is not in use, fit it over the lens in the reverse position. Turn the hood clockwise to lock it in place.

SPECIFICATIONS

Type	Lens	Groups- elements	Dia- phragm	Angle of view
UL TRA- WIDE-ANGLE	SMC Pentax-FA★ 24mmf/2AL(IF)	9-11	F.A.	84°
WIDE-ANGLE	SMC Pentax-FA 28mmf/2.8AL	5-5	F.A.	75°
STANDARD	SMC Pentax-FA 50mmf/1.4	6-7	F.A.	47°
	SMC Pentax-FA 50mmf/1.7	5-6	F.A.	47°
MEDIUM- TELEPHOTO	SMC Pentax-FA★ 85mmf/1.4(IF)	7-8	F.A.	28.5°
	SMC Pentax-FA 135mmf/2.8(IF)	7-8	F.A.	18°
TELEPHOTO	SMC Pentax-FA★ 200mmf/2.8ED(IF)	8-9	F.A.	12.5°
	SMC Pentax-FA★ 300mmf/2.8ED(IF)	7-10	F.A.	8.2°
	SMC Pentax-FA★ 300mmf/4.5ED(IF)	7-9	F.A.	8.2°
ULTRA- TELEPHOTO	SMC Pentax-FA★ 600mmf/4ED(IF)	7-9	F.A.	4.1°
ZOOM	SMC Pentax-FA★ ZOOM 28-70mmf/2.8AL	11-14	F.A.	75-34.5°
	SMC Pentax-FA ZOOM 28-80mmf/3.5-4.7	8-8	F.A.	75-30.5°
	SMC Pentax-FA ZOOM 28-105mmf/4.5-5.6	11-13	F.A.	75-23.5°
	SMC Pentax-F ZOOM 35-80mmf/4-5.6	6-7	F.A.	63-30.5°
	SMC Pentax-FA ZOOM 70-200mmf/4-5.6	8-10	F.A.	34.5-12.5°
	SMC Pentax-FA★ ZOOM 80-200mmf/2.8ED(IF)	13-16	F.A.	30.5-12.5°
	SMC Pentax-F ZOOM 80-200mmf/4.7-5.6	7-11	F.A.	30.5-12.5°
	SMC Pentax-FA ZOOM 100-300mmf/4.5-5.6	8-12	F.A.	24.5-8.2°
SMC Pentax-FA★ ZOOM 250-600mmf/5.6ED(IF)	16-18	F.A.	9.9-4.1°	
MACRO	SMC Pentax-FA MACRO 50mmf/2.8	7-8	F.A.	47°
	SMC Pentax-FA MACRO 100mmf/2.8	8-9	F.A.	24.5°

- AL = Aspherical lens
- ED = Achromatic lens including elements of the Extra-low Dispersion glass
- IF = Lens featuring the inner focusing mechanism

SPECIFICATIONS ARE SUBJECT TO CHANGE AT ANY TIME WITHOUT NOTIFICATION OR ANY OBLIGATION ON THE PART OF THE MANUFACTURER.

Minimum focus dist. <m>	Maximum Magnification <X>	Minimum aperture <F>	Max. Dia. × length <ϕ mm × mm>	Weight <g>	Filter size <mm>
0.3	0.12	22	72.5 × 65.5	405	67
0.3	0.13	22	65 × 40.5	185	49
0.45	0.15	22	65 × 37	220	49
0.45	0.15	22	65 × 37	170	49
0.85	0.11	22	79 × 70	550	67
0.7	0.25	32	68 × 80	375	52
1.2	0.2	32	83 × 134	785	77
2.0	0.17	32	123 × 256	2680	43(112)‡
2.0	0.17	32	72.5 × 160	935	43
5.0	0.13	32	176 × 457	6450†	43(150)‡
0.43	(0.25)	22	84.5 × 104	800	67
0.4	0.25	22-32	71 × 83.5	380	58
0.43	(0.33)	22-32	72.5 × 95.5	515	58
0.4	(0.25)	22-32	65 × 58	185	49
1.1	0.25	32-45	73 × 116.5	465	49
1.4	(0.19)	32	87.5 × 191.5	1510†	77
1.1	(0.25)	32-38	65 × 97.5	295	49
1.5	(0.25)	32-38	73 × 154.5	605	58
3.5	0.2	32	134 × 442	5050†	43(112)‡
0.195	1.0	32	68 × 70	385	52
0.306	1.0	32	74 × 103.5	600	58

F.A. = Fully automatic

† = Weight without the tripod mount

‡ = Figures in () of Filter size indicate the thread diameter of the front ring.

Note : Lens length does not include mount portion.

PENTAX FA-LENS SOFT CASE

The soft case code numbers are assigned to the various Pentax FA lenses for reference as shown in the table.

Specify the lens you have when ordering the case, referring to the table.

Code number on the case	SMC Pentax FA lens
S70-70	28mmf/2.8 50mmf/1.4 50mmf/1.7
S80-80	Zoom 35-80mmf/4-5.6
S80-120	135mmf/2.8(IF) Macro 50mmf/2.8 Zoom 28-105mmf/4.5-5.6 Zoom 28-80mmf/3.5-4.7 Zoom 80-200mm f/4.7-5.6
S80-160	Macro 100mmf/2.8 Zoom 70-200mmf/4-5.6 Zoom 100-300mmf/4.5-5.6
S90-100	FA* 24mmf/2(IF)
S90-160	FA* 300mmf/4.5ED(IF)
S100-160	FA* 200mmf/2.8ED(IF)
S120-150	FA* 85mmf/1.4(IF) FA* Zoom 28-70mm f/2.8AL
S120-230	FA* Zoom 80-200mmf/2.8ED(IF)
S135-340	FA* 300mmf/2.8ED(IF)
Trunk case	FA* 600mmf/4ED(IF) FA* Zoom 250-600mmf/5.6ED

WARRANTY POLICY

All Pentax lenses purchased through authorized bona fide photographic distribution channels are guaranteed against defects of material or workmanship for a period of twelve months from date of purchase. Service will be rendered and defective parts will be replaced without cost to you within that period, provided the equipment does not show evidence of impact, sand or liquid damage, mishandling, tampering, operation contrary to operating instructions, or modification by an unauthorized repair shop. The manufacturer or its authorized representatives shall not be liable for any repair or alterations except those made with its written consent and shall not be liable for damages from delay or loss of use or from other indirect or consequential damages of any kind, whether caused by defective material or workmanship or otherwise; and it is expressly agreed that the liability of the manufacturer or its representatives under all guarantees of warranties, whether expressed or implied, is strictly limited to the replacement of parts as hereinbefore provided. No refunds will be made on repairs performed by non-authorized Pentax service facilities.

PROCEDURE DURING 12-MONTH WARRANTY PERIOD

Any Pentax lens which proves defective during the 12-month warranty period should be returned to the dealer from whom you purchased the equipment or to the manufacturer. If there is no representative of the manufacturer in your country, send the equipment to the manufacturer, with postage prepaid. In this case, it will take a considerable length of time before the equipment can be returned to you owing to the complicated customs procedures. If the equipment is covered by warranty, repairs will be made and parts replaced free of charge, and the equipment will be returned to you upon completion of servicing. If the equipment is not covered by warranty, regular charges of the manufacturer or of its representatives will apply. Shipping charges are to be borne by the owner. If your Pentax lens was purchased outside of the country where you wish to have it serviced during the warranty period, regular handling and servicing fees may be charged by the manufacturer's representatives in that

country. Notwithstanding this, your Pentax camera or lens returned to the manufacturer will be serviced free of charge according to this procedure and warranty policy. In any case, however, shipping charges and customs clearance fees are to be borne by the owner. To prove the date of your purchase when required, please keep the receipts or bills covering the purchase of your equipment for at least a year. Before sending your equipment for servicing, please make sure that you are sending it to the manufacturer's authorized representatives or their approved repair shops, unless you are sending it directly to the manufacturer. Always obtain a quotation for the service charge, and only after you accept the quoted service charge, instruct the service station to proceed with the servicing.

This warranty policy does not apply to Pentax products purchased in the U. S. A. , U. K. , or Canada. The local warranty policies available from Pentax distributors in those countries supersede this warranty policy.



Asahi Optical Co., Ltd. 11-1, Nagata-cho 1-chome, Chiyoda-ku, Tokyo 100, JAPAN
Pentax Europe n.v. Weiveldlaan 3-5, 1930 Zaventem, BELGIUM
Pentax Handelsgesellschaft mbH, Julius-Vosseler-Strasse, 104, D-22527 Hamburg, GERMANY
Pentax U.K. Limited, Pentax House, Heron Drive, Langley, Slough SL3 8PN, U.K.
Pentax France S.A. Z.I. Argenteuil, 12, rue Ambroise Croizat, 95100 Argenteuil, FRANCE
Pentax Benelux (for Netherlands) Spinveld 25, 4815 HR Breda, NETHERLANDS
(for Belgium & Luxembourg) Weiveldlaan 3-5, 1930 Zaventem, BELGIUM
Pentax (Schweiz) AG Industriestrasse 2, 8305 Dietlikon, SWITZERLAND
Pentax Scandinavia AB Falhagsleden 57, 75127 Uppsala, SWEDEN
Pentax Corporation 35 Inverness Drive East, Englewood, Colorado 80112, U.S.A.
Pentax Canada Inc. 3131 Universal Drive, Mississauga, Ontario L4X 2E5, CANADA
Asahi Optical Brasileira Ind. e Com. Ltda. Rua Dr. Renato Paes de Barros, 714 CJ. 103/104 Itaim Bibi,
São Paulo CEP 04530-001, BRAZIL.