

WILSONWERKS ARCHIVES

This camera manual is for reference and historical purposes, all rights reserved.

This cover page is copyrighted material. This document may not be sold or distributed without the express consent of the publisher.

©2008 wilsonwerks Llc

SPECIFICATIONS

Type: 35mm SLR camera with multi-mode automatic exposure controls, electronically-controlled focal plane shutter

Exposure Control Mode Selection: By using combinations of settings on shutter dial and aperture ring of *A Series* lenses.

Film Format: 35mm film, 24 x 36mm

Lens Mount: Pentax KA Bayonet (Pentax K bayonet mount with electrical contact).

Shutter: Seiko MFC-E3 vertical-run metal focal-plane shutter, automatic exposure and manual settings, electronically-controlled speeds from 15 to 1/2000 sec., 1/125 sec., and B. Electro-magnetic shutter release with release button lock.

Exposure Indication in Viewfinder: Liquid Crystal Display (LCD). Automatic and manual shutter speeds, automatically set lens apertures, exposure factor warning, shutter-speed setting error warning, battery life warning, and Programmed AE indication (P).

External Indication: Automatic and manual shutter speeds, Programmed AE indication (P) and shutter cocked indicator.

Flash Synchronization: Hot shoe (X-Synch contact, dedicated flash contacts), X-synch at 1/125 sec.

Self-Timer: Electronically controlled, delay time indication by flashing lamp and electronic beep, 12 sec. delay time. Possible to cancel at any time; initiate process by pressing shutter release button.

Viewfinder: Silver-coated pentaprism finder with split-image/microprism focusing screen; shows 92% of the picture area, 0.82X magnification with 50mm lens at infinity; -1.1 Diopter eyepiece.

Mirror: Back-swing type instant-return mirror.

Film Loading: Magic-needle loading.

Film Transport: Single-stroke, rapid wind lever with 135° throw and 30° stand-off angle; LCD shutter cocked indicator; film advance and rewind indicator window.

Exposure Counter: Additive type, automatic resetting. Automatically sets shutter-speed at 1/1000 sec. up to '0' frame on the counter when shutter dial is set at AUTO or M.

Film Rewind: Crank type.

Exposure Metering: Open aperture, Through-The-Lens, center weighted metering system with GPD cell. Film-plane metering for dedicated automatic electronic flashes.

Metering Range: EV 1 (f/1.4, 1 sec.)—EV 19 (f/16, 1/2000 sec. or f/22, 1/1000 sec.) with 50mm f/1.4 lens and ASA/ISO 100 film.

ASA/ISO Range: 6—3200.

Exposure Compensation: Compensation dial indexed at 4X, 2X, 1X, 1/2X and 1/4X.

Power Source: Two 1.5V alkaline or silver-oxide batteries, or one 3V lithium battery. Switched on by shutter release button and remains on for about 30 sec., shut-off by built-in timer.

Battery Warning: When batteries grow weak, LCD alternately flashes exposure designations and 'ooo' sign. When batteries exhausted, LCDs go blank and shutter locks.

Back Cover: Standard camera back with spring catch, built-in memo holder/grip, fully interchangeable with Dial Data ME and Digital Data M.

Size: 131.0(W) x 86.5(H) x 47.5mm(D) (5.1" x 3.4" x 1.9")

Weight: 490 gr. (17.3 oz) (Without batteries)

PENTAX®

Pentax Corporation 35 Inverness Drive, East, Englewood, Colorado 80112, U.S.A.
Pentax Canada Inc. 1760 West 3rd Avenue, Vancouver, B.C. V6J 1K5, CANADA



Prices are subject to change without notice.

06191•Printed in U.S.A.

PENTAX

SUPER PROGRAM



THE SUPER PROGRAM EXPERIENCE

Total Control through Electronics

PENTAX SUPER PROGRAM

MODE1 PROGRAMMED AUTO

The camera sets both shutter speed and f-stop. It's the spontaneous mode. Just focus and shoot.

MODE2 APERTURE-PRIORITY AUTO

You set f-stop, the camera chooses shutter speed. The right system for depth-of-field control.

MODE3 SHUTTER-PRIORITY AUTO

You select shutter speed, the camera sets f-stop. The best mode for stop-action shots.

MODE4 METERED MANUAL

You select both shutter speed and f-stop to create precisely the effect you want.

MODE5 TTL AUTO FLASH

A sensor in the camera body measures the light reaching the film and automatically controls flash output based on the aperture you select. The best mode for close-up, bounce & sophisticated flash photos.

MODE6 PROGRAMMED AUTO FLASH

Both shutter speed and f-stop are automatically set by the flash unit. The fastest, simplest mode for general flash work.

PLUS SPECIAL WARRANTY COVERAGE

The Super Program camera is an exclusive North American model which carries a special two year limited warranty. Pentax lenses carry a one year limited warranty.

The Pentax Super Program gives you the best of photography's many worlds. From the absolute simplicity of programmed automation to the intricacies of remotely-controlled, multi-flash, motor-drive exposures. Whatever the situation, the Super Program has a smooth solution.



To give you a new sensation of total control over the photographic moment, the Super Program combines computer sophistication with complete functional ease. Elegantly compact, delightfully easy to use, yet offering an unprecedented wealth of features, the Pentax Super Program is a photographer's fantasy come true.

PENTAX SUPER PROGRAM

P2000



P500

F16

MODE 1 PROGRAMMED AUTO



Shutter Dial: Auto
Lens: Auto
(*A Series lenses only)

P 125

F8

The purpose of the Program mode is not only to make photography easier, but make it faster, more spontaneous, more responsive to unique opportunities that occur for an instant, then vanish for good. To enjoy the convenience of programmed exposure, just set the camera and the A Series lens to Auto. Then simply frame, focus and shoot.

P	
P 2000	F45
P 1000	F22
⋮	⋮
P 1"	F14
P 15"	F14
P 125	F8 EF
P 1000	F22

In the Program mode, the viewfinder will show the following information: 'P' for Program and shutter speed in the left panel, f-stop in the right panel. There are also special displays for exposure compensation and flash readiness, as well as blinking numbers to warn of over or under-exposure or low battery power.

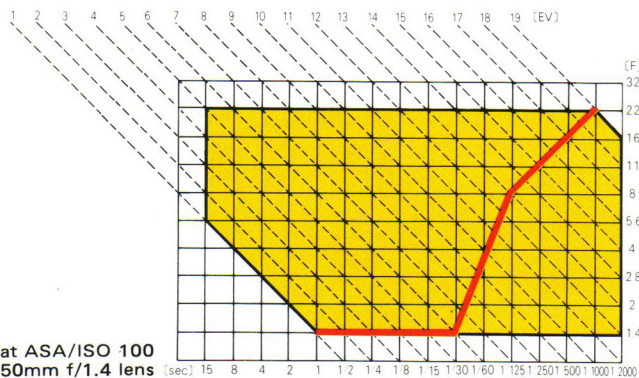

Programmed for high shutter speeds

The exposure program in the Super Program is designed to offer the highest practical shutter speed at each light level. This means that you can use the Super Program for hand-held shots in situations where other programmed cameras require a tripod or flash. The extended shutter speed range of the Super Program (up to 1/2000th second at ASA/ISO 400) offers a real advantage because spontaneous, hand-held shooting is the prime purpose of programmed automation.

MODE 2 APERTURE-PRIORITY AUTO

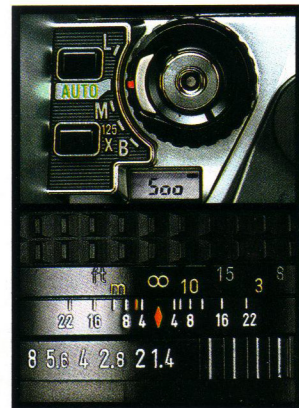

Shutter Dial: Auto
Lens: Manual
(‘A’ Series and K mount lenses)

When depth-of-field is a critical consideration in your photo, use the Super Program’s Aperture Priority mode. A small aperture gives you great depth of field, while a large aperture leads to shallow focus. In each case, the camera automatically selects the proper shutter speed. You can use this mode with an A Series lens set on Manual, as well as with all other SMC Pentax lenses.

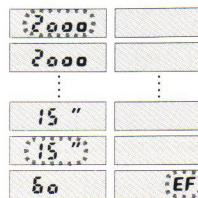

In the Aperture Priority mode, the left panel of the viewfinder shows the shutter speed. There are also special displays for exposure compensation, plus blinking numbers to warn of over or under-exposure.

Exposure Compensation

Whichever mode you’re using, you can adjust for back-lighting or front-lighting with the Super Program’s exposure compensation dial. Four steps from 4X to 1/4X give you all the latitude needed to create special effects with light.

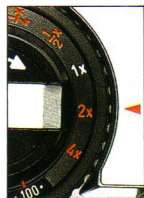

Macro Photos with Automatic Ease

Aperture Priority Automation is the most convenient mode for extreme close-ups, macro photography and slide-copying.

Freedom to select any aperture gives you great control over depth-of-field. And the Super Program provides automatic exposure control with a wide variety of specialized macro accessories.

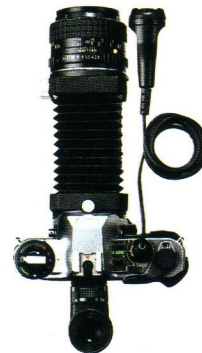

MODE 3 SHUTTER-PRIORITY AUTO



When the action is fast, or when motion is the prime factor in your picture, the Shutter Priority mode lets you catch precisely the effect you want. Set the camera body on manual and your A Series lens on auto. Now you can select shutter speeds from 1/2000th second to 15 seconds while the camera automatically chooses the proper f-stop.



Shutter Dial: Manual
Lens: Auto
(*A' Series lenses only)

In the Shutter Priority mode, the left panel shows shutter speed, the right shows f-stop. Blinking numbers warn against a speed/f-stop combination that can't produce a proper exposure.

2000	F4.5
125	F3.2
...	...
125	F14
125	F4 EF
1"	F14
500	F14
15"	F22
2000	F22
2"	F14



MODE 4 METERED MANUAL

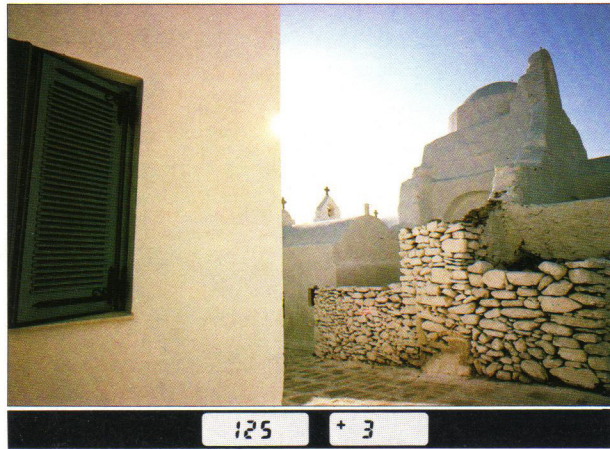

When both the camera and the lens are set on Manual, you have complete creative control over all exposure factors. Saturate colors by under-exposing, emphasize light, depth or motion at will. The precise control of the Manual mode can be enjoyed with A Series and all other Pentax SMC lenses.



Shutter Dial: Manual
Lens: Manual
(*A' Series and K mount lenses)

2000	+3
2000	+3
...	...
...	+2
...	+1
...	±0
...	-1
...	-2
...	-3
15"	-3
125	+3
B	

In the Manual mode, the left panel shows shutter speed, while the right panel shows numbers from +3 to -3. The numbers tell how far over or under-exposed your setting is. +3 means three stops over. ±0 means right on. -3 means three stops under. 'Bulb' shows you are set for a time exposure.

MODE 5 TTL AUTO FLASH

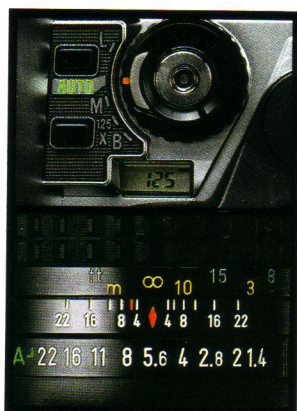

Shutter Dial: Auto
 Lens: Manual
 ('A' Series and K mount lenses)
 Dedicated Flash Unit: TTL mode

In the TTL Auto mode, flash output is determined by a sensor in the camera body. This sensor measures the light that comes through the lens and reaches the film plane. It automatically terminates flash when the proper amount of light has reached the film. To take full advantage of TTL Auto Flash, you should use the Super Program in its Aperture Priority mode (body on Auto, lens on Manual). This gives you the freedom to shoot flash at any aperture, achieving greater control over depth-of-field in flash photos. TTL Auto is also very handy for close-up flash photography. And TTL Auto Flash is just about foolproof because the correct light dosage is automatically determined right at the film plane during the actual moment of exposure.

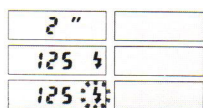

In the TTL Flash mode, the left panel shows the shutter speed, and tells you when the flash unit is charged, and blinks to indicate a successful exposure.

MODE 6 PROGRAMMED AUTO FLASH

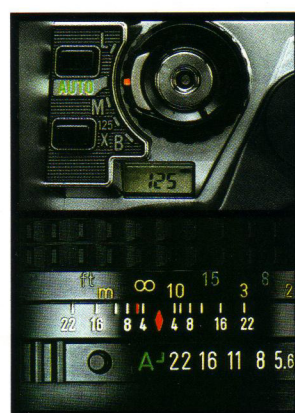
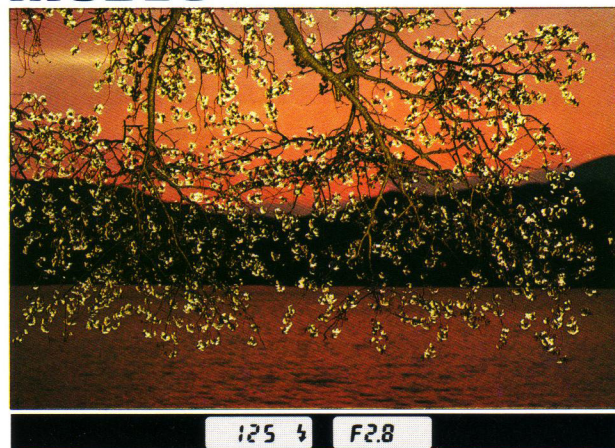

Shutter Dial: Auto
 Lens: Auto
 ('A' Series lenses only)
 Dedicated Flash Unit: Auto mode

Programmed Auto Flash is the ultimate in convenience. This mode lets you take general flash photos with speed, security and automatic ease. You should set the Super Program in its Program mode (body and lens on Auto). Your Pentax dedicated flash unit should also be set to Auto. Once the lightning bolt symbol is visible in the viewfinder (indicating that the flash has charged), all you have to do is press the shutter button. Shutter speed will be automatically set to 1/125 second, and lens aperture will be automatically adjusted to the proper f-stop. If you want to create special effects with flash, you can also use the Super Program in its Manual model.

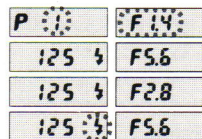

In the Programmed Flash mode, you see shutter speed in the left panel, and f-stop in the right.

There are also indications for flash readiness and successful flash exposure.



1 2
3 4 5 6 7 8 9 10 11 12 13 14

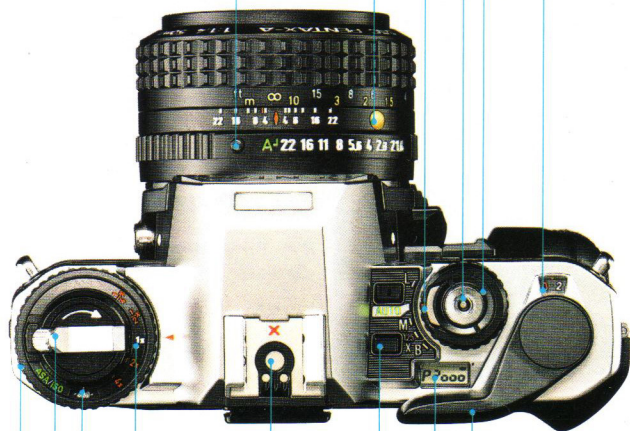

15 16 17 18 19 20 21 22



Advantages of the new KA mount.

The Super Program is the first camera to feature the new KA lens mount. This mount is specially designed for a multi-mode camera. It has extra electronic contacts that enable the camera to automatically detect and control lens aperture, thereby permitting Shutter-Priority and Programmed Auto operation.

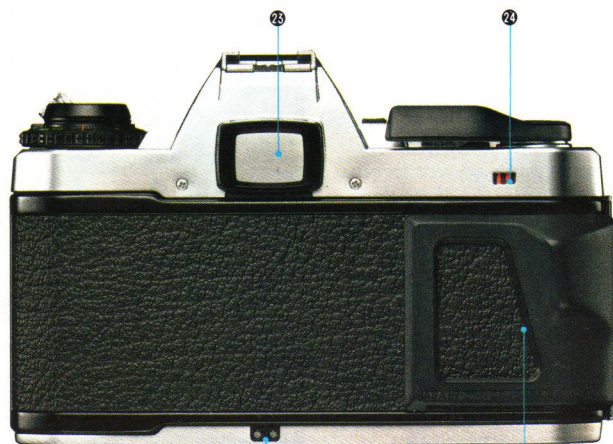

23 24 25 26



27 28 29 30 31 32 33

- 1 Illuminating window
- 2 X-synch terminal
- 3 Grip *Super A*
- 4 Mount screw
- 5 Self-timer lever
- 6 Preview lever
- 7 Lens release lever
- 8 Aperture auto lock button
- 9 Lens alignment node
- 10 Shutter dial lock button
- 11 Shutter release button
- 12 Shutter dial
- 13 Bevelled bottom edge
- 14 Exposure counter
- 15 ASA/ISO film speed dial
- 16 Rewind crank/Back cover release knob
- 17 ASA/ISO film speed scale
- 18 Exposure compensation dial
- 19 Hotshoe
- 20 Electro-Touch shutter speed select button
- 21 Shutter speed LCD (External LCD)
- 22 Film advance lever
- 23 Viewfinder eyepiece
- 24 Film advance/rewind indicator
- 25 Connector
- 26 Cordless contact terminal
- 27 Lighting button for viewfinder LCDs
- 28 Memo Holder/Thumb Grip
- 29 Winder/Motor Drive contact terminal
- 30 Film rewind button
- 31 Tripod socket
- 32 Battery compartment cover
- 33 Connector

TEN EXTRA ADVANTAGES OF THE SUPER PROGRAM

ASA/ISO Setting, Exposure Factor

Below the film-rewind lever, you'll find a dial that lets you set ASA/ISO film speed and adjust exposure factor. If you've adjusted for either over or under-exposure, a viewfinder light will come on, reminding you to set the dial back to '1X' before the next shot.

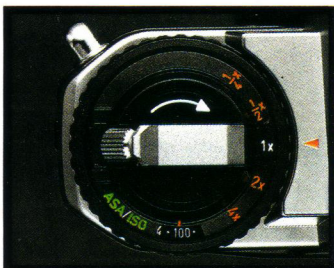

Self-Timer

The Super Program makes it easy for you to get in the picture, too. Simply slide open the self-timer and press the shutter release. You now have approx. 12 seconds to position yourself in front of the lens. A red LED helps you count the seconds by blinking slowly for the first ten and quickly for the last two.



Depth of Field Preview Lever

When depth-of-field is a vital factor, check the focus at the aperture you've selected by looking through the viewfinder with the preview lever depressed. You may not use the preview for every photo, but in certain situations it's a very handy feature.

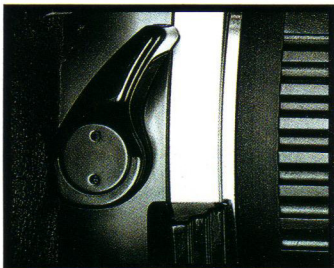

Grip Super A

In addition to the built-in thumb grip on the Super Program, you also have a removable front grip. The combination of these two grips gives you a rock-solid hold on the camera, permitting one-handed shooting in many situations.



Clear Bright Matte Screen

The viewfinder of the Super Program is exceptionally convenient for focusing. A special treatment has been applied to the viewfinder screen to significantly increase clarity and brightness even in poor light.

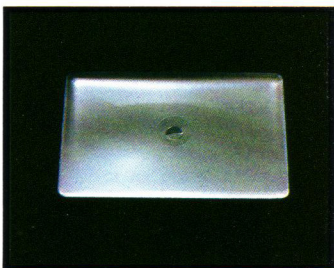

Advance to Zero

After loading film, you have to advance two frames before reaching '0'. Since this can be time-consuming with a slow shutter speed, the Super Program speeds things up by automatically releasing the shutter at 1/1000 sec. until the film counter comes to '0'.

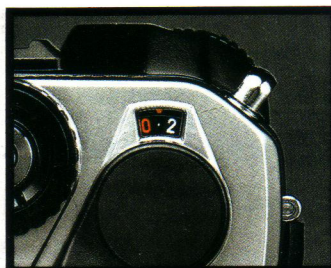

Shutter Speed Buttons

You don't have to twist an awkward dial to set shutter speeds on the Super Program. Electro-Touch pushbuttons let you adjust speed with ease while framing the subject in the viewfinder. Shutter speeds are displayed in digital readouts both in the viewfinder and on an external panel.



For Brighter Displays

Very strong or very weak light sometimes makes it difficult to read LCD displays. The Super Program solves this problem with a special button that throws added illumination on the digital read-out. Night or day, the Super Program's viewfinder keeps you fully informed.

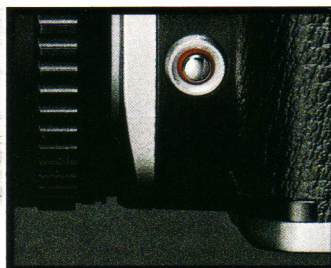

Memo Holder Grip

The film memo on the Super Program provides double convenience. It not only reminds you of the type and speed of film you're shooting, it also features a special thumb grip that gives you a very secure hold on the camera.

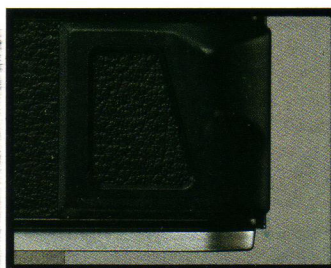

Magic Needles

Film-loading is fast and foolproof with the Super Program. Simply insert the leader between any two of the flexible plastic rods on the take-up-spool. They grip the film securely on the first try, letting you load your film in a matter of seconds.

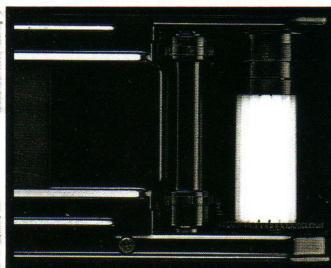

THE INTERFACE OF THREE TECHNOLOGIES

The intersection of three technologies creates the extraordinary versatility of Pentax Super Program. The latest advances in microelectronics are represented by C-MOS and Bi-Polar LSIs, Quartz Oscillating Circuitry and digital Liquid Crystal Displays. The microprocessor brain of the Super Program, which controls and coordinates all six exposure modes, has a sophistication that surpasses other SLRs.

A very high level of mechanical engineering and reliability is also evident in the Super Program. Electronic components have replaced many moving parts, but those that remain are designed for impeccable performance.

Finally, Pentax optical expertise is also a vital factor. The *A Series* lenses which are designed to make the most of the Super Program's many capabilities feature important advances in lens composition and engineering.

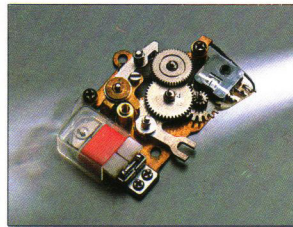

Optical Encoder for Aperture Control

The Optical Encoder for aperture control is an example of the sophisticated blend of technologies in the Super Program. An LED which emits a light beam, a miniature gear with cogs that break the beam, a sensor/transistor that counts the interruptions of the beam, and a magnet to lock or release the aperture ring—these are all parts of the system which enables the Super Program to automatically adjust aperture settings in the Program and Shutter Priority modes.

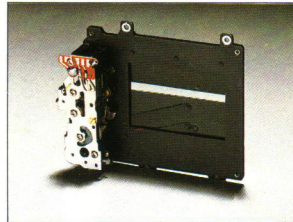

Super Shutter

The Super Program's electronically-controlled focal plane shutter is another high-tech feature. It not only offers a very wide range of automatically controlled speeds (from 1/2000 to a full 15 seconds), it also has an unusually short lead time. Lead time is the fraction of a second that passes between the moment the shutter button is depressed and the moment the shutter springs into action. The shorter lead time of the Super Program's shutter reduces camera shake and permits faster photographic response.

Shutter speed also displayed on external LCD.

In the Programmed Auto mode, "P" appears on the external LCD even if power is switched off. When power is switched on, shutter speed appears in all modes.

Dual shutter speed indication is an exclusive Super Program feature. It is convenient and efficient, especially for close-up photography and similar situations.

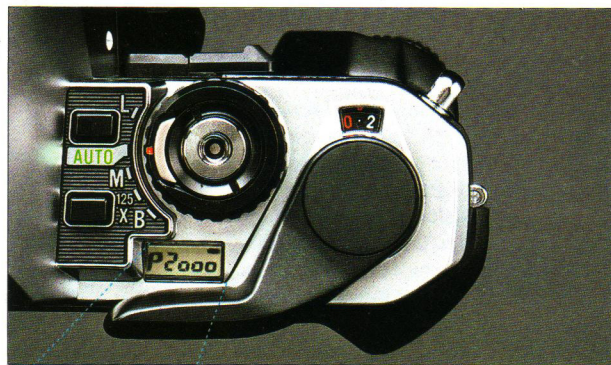
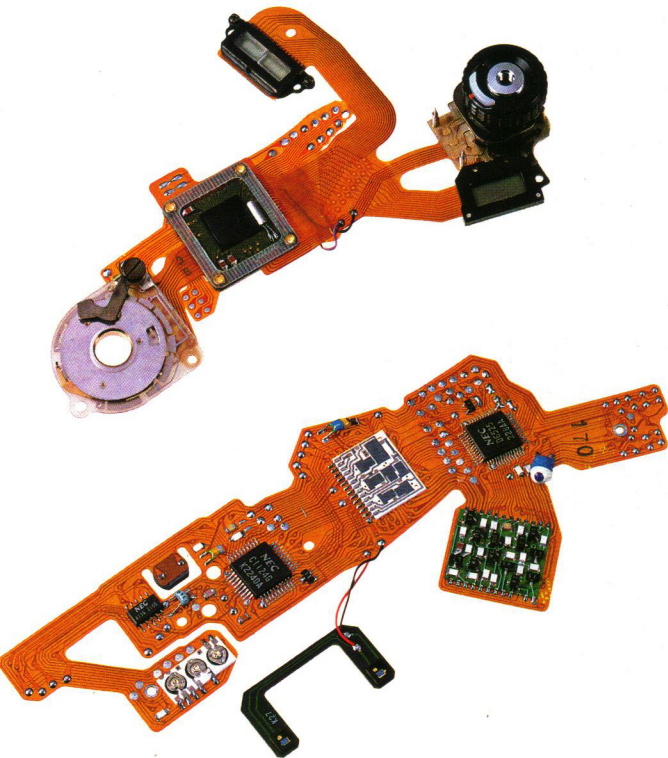

- Confirms that film is advanced and shutter cocked.
- Indicates shutter speed in use.
- Denotes Programmed Auto mode.

BRIGHT DIGITAL INFORMATION

An integrated digital-information viewfinder, with a bright, high-contrast LCD, is featured in the new Pentax Super Program. Exposure data are indicated in easy-to-read letters and numbers. Whichever mode you select, exposure information is clear, concise and complete. Finder displays help you take full advantage of the Super Program's multi-function, multi-mode ability. Because the LCD consumes very little power, it prolongs battery life.

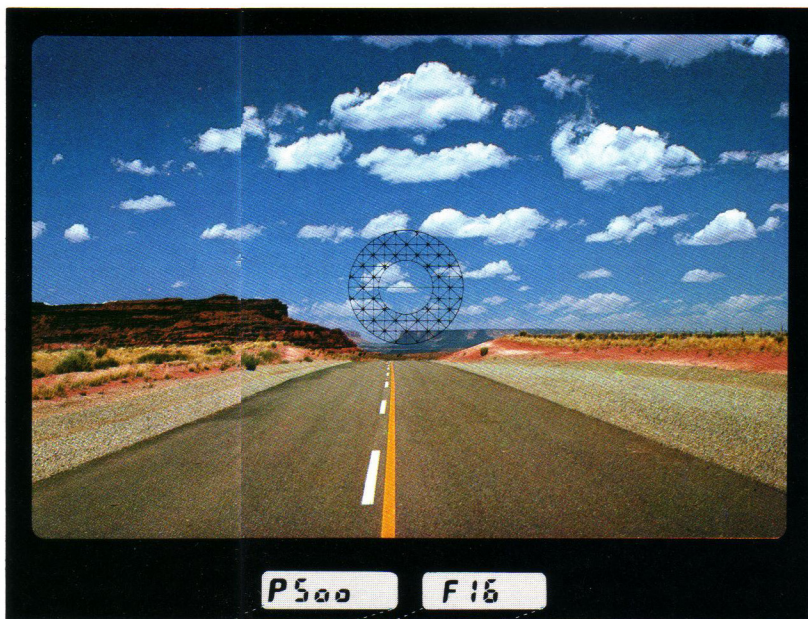

Fastest shutter speed—1/2000 sec.

Shutter Speed LCD

In Programmed Auto and Aperture-priority Auto modes, the shutter speed varies steplessly. The display shows the speed closest to the one actually selected.

2 seconds—"(") stands for second.

In Programmed mode, the letter "P" is displayed in front of the shutter speed.

Bulb exposure in the Manual mode.

In TTL auto flash and Programmed auto flash modes, indicates that the flash is charged and the shutter speed has been automatically set to flash synchronization. Flickering $\frac{1}{2}$ mark after flash denotes that the unit has discharged the proper amount of light.

This "error" mark appears when controls are set improperly.

Battery warning. When battery voltage is low, this marking and normal exposure data alternate to advise you that the battery should be replaced.

- 2000
- 1000
- 500
- 250
- 125
- 60
- 30
- 15
- 8
- 4
- 2
- 1
- 2"
- 4"
- 8"
- 15"
- P
- B
- 125 $\frac{1}{2}$
- [Error mark]
- [Battery warning mark]

20 ●

Aperture LCD

An f-stop displayed in 21 steps with 1/2-step increments.

In Programmed Auto and Shutter Priority modes, the aperture is steplessly adjusted. The f-stop closest to the actual value is displayed.

(No LCD indication of aperture in Aperture-priority and Manual modes.)

Flickers when exposure compensation is being used.

In Manual mode, under-, over- or correct exposure is indicated by the number +3 to -3. ± 0 means correct exposure.

- F1.2
- F1.4
- F2
- F2.5
- F2.8
- F3.5
- F4
- F4.5
- F5.6
- F6.7
- F8
- F9.5
- F11
- F13
- F16
- F19
- F22
- F27
- F32
- F38
- F45
- [Flicker mark]
- ± 0
- [Error mark]

● 21

"A SERIES" LENSES FEATURE OPTICAL AND FUNCTIONAL INNOVATIONS



New SMC Pentax A Series Lenses

To take full advantage of the Super Program's six exposure modes, you'll want to use the new series of 'A' lenses, developed especially for this and future Pentax cameras.

'A' lenses have a new mount. Called the KA mount, it features extra electrical contacts for transmission of aperture information and automatic control of aperture settings. In the Manual and Aperture Priority modes, these contacts enable the Super Program's brain to determine the maximum aperture and the aperture currently set on the lens you're using. 'A' lenses also have a locking Auto "A" setting on the aperture ring. When the ring is set to Auto, the camera can automatically change lens aperture in the Program and Shutter Priority modes.

In these modes, aperture settings must be adjusted in the very brief instant between shutter release and film exposure. Through

advanced technology, 'A' lenses meet the challenge, providing smooth, swift and accurate aperture control. The KA mount is extremely durable and designed to stand up to frequent lens changes over a long period of time. A Series lenses, with their KA mounts, can also be used on all K mount Pentax SLRs.

Optical advances in A Series lenses

A Series lenses offer not only electronic and mechanical innovations for automatic aperture control, but optical technology and image quality which also reflect a new standard of superiority. Experience and data gathered during decades of lens production, the latest computer aided lens design and grinding techniques, plus the unique Pentax process of Super Multi Coating—all these factors combine to make A Series lenses as exciting as the Super Program.

THE "A SERIES"—OUR NEWEST AND FINEST LENSES

● Type	● Lens	● Minimum Aperture		● Angle of View (Degree)	● Lens Construction (Groups-Elements)	● Diaphragm		● Minimum Focusing Distance	● Maximum Diameter & Length (ømm x mm)	● Weight		● Filter Size (mm)
		mm	ft.			mm	ft.			gr.	oz.	
WIDE-ANGLE	SMC Pentax-A 24mm f/2.8	22	84	8.9	FA	0.25	0.79	63x41.5	205	7.2	52	
	SMC Pentax-A 28mm f/2.8	22	75	7.7	FA	0.3	1.0	63x36.5	170	6.0	49	
	SMC Pentax-A 35mm f/2.8	22	63	6.6	FA	0.3	1.0	63x36.5	170	6.0	49	
STANDARD	SMC Pentax-A 50mm f/1.4	22	47	6.7	FA	0.45	1.5	63x37	235	8.3	49	
	SMC Pentax-A 50mm f/1.7	22	47	5.6	FA	0.45	1.5	63x31	165	5.8	49	
TELEPHOTO	SMC Pentax-A 135mm f/2.8	32	18	4.4	FA	1.2	4	65x76.5	340	12.0	52	
	SMC Pentax-A 200mm f/4	32	12.5	6.6	FA	1.9	6.2	63.5x111	410	14.5	52	
SUPER TELEPHOTO	SMC Pentax-A* 300mm f/4	32	8.3	7.8	FA	4	13	84.5x132	850	30.0	77	
	SMC Pentax-A* 600mm f/5.6 ED (IF)	45	4.1	6.8	FA	5.5	18	133x386	3280	115.7	49	
ZOOM	SMC Pentax-A Zoom 24~50mm f/4	22	84-47	10-11	FA	0.4	1.4	64x67.5	375	13.2	58	
	SMC Pentax-A Zoom 35~105mm f/3.5	22	63-23.5	13-15	FA	1.5	5	70x97.5	615	21.7	67	
	■ SMC Pentax-A Zoom 28~135mm f/4	22	75-18	15-17	FA	1.7	5.6	80x112	820	28.9	77	
	SMC Pentax-A Zoom 70~210mm f/4	32	34.5-12	10-13	FA	1.2	4	72x149	680	24.0	58	
MACRO	■ SMC Pentax-A Macro 50mm f/2.8	22	47	4.6	FA	0.24	0.79	63x50	220	7.8	49	

■ Soon to be released. FA Fully Automatic. Note: Lens length does not include mount portion.



Extra Low Dispersion Glass and Inner Focus

As an example of the new technology in A Series lenses, look into the advanced design of the SMC Pentax A* 600mm f/5.6. This ultra-telephoto lens reduces chromatic aberration with an extra low dispersion (ED) optical element. Extra low dispersion glass attains performance levels not possible with conventional optical glass.

Inner focus is another innovation in the A* 600mm. The rear element group moves inside the barrel. The length and the balance of the lens do not change as you focus. This makes focusing smoother and faster.

Interchangeable Lenses

You can also use the Super Program with the full range of Pentax lenses. Since these lenses do not have the special contacts of the new A Series, they cannot be used in all six of the Super Program's modes. But they still give you a choice of three modes—Aperture Priority, Manual and TTL Flash. If you're already a Pentax owner, there's no need to rush out and buy a whole new set of lenses to enjoy the excitement of the Super Program. You'll probably want to start with at least one A Series lens, but you can keep on using the Pentax lenses you own right now.

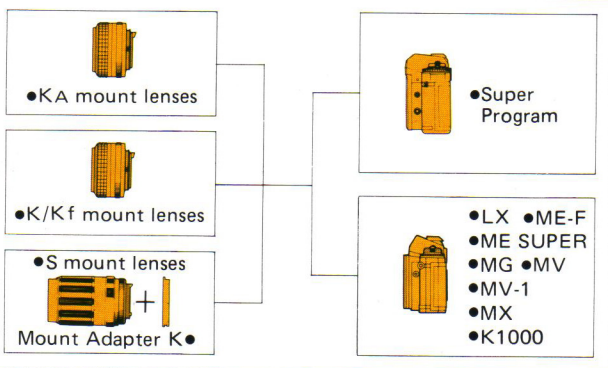

THE DRAMA OF ACTION PHOTOGRAPHY



Dynamic, high quality aids for the action photographer

To shoot high-speed action sequences, equip your *Super Program* with the 3.5 frame-per-second motor drive. This compact accessory has a built-in battery pack, making it lighter than conventional motor drives. For further convenience, it offers two shutter release buttons, one ideally positioned for using the camera in the horizontal position, the other placed for ease in taking vertical shots. There is also a contact allowing you to set the Super Program as a remote-control motor drive camera. With the motor drive, you can use the Super Program in any mode for either single-frame or continuous shooting with adjustable speeds. You can also use the Super Program with the Winder ME II for automatic film advance.

Motor Drive A

Type: Automatic film winder for Pentax Super Program.

Operating Mode: Single-frame (S) and Continuous (C) via C/S dial of motor drive. The C/S dial doubles as a power switch.

Winding Speed: Two speed setting; H (approx. 3.5 fps) ~ L (approx. 2 fps)

Shutter Release: Camera shutter release button, two built-in shutter release buttons for horizontal and vertical camera positions.

Function Check: Red LED illuminates to confirm release of shutter and transport of film.

Usable Shutter Speed: All shutter speeds except B (Bulb).

Power Source: Eight 1.5V AA-size batteries.

Battery Life: Manganese batteries: 40 or more rolls of 36-exposure film. Alkaline manganese batteries: 80 or more rolls of 36-exposure film (under normal temperature and humidity).

Size and Weight: Motor Drive A: 142(W)x81(H)x70mm(D), 260g (5.5"x3.2"x2.7", 9.2 oz.) Battery Pack A: 143(W)x35.5(H)x71.5mm(D), 175gr. (5.6"x1.4"x2.8", 6.2 oz. without batteries)

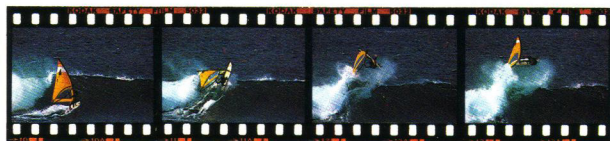

Remote Control with Cords

In addition to cordless infrared remote control, the Super Program is also designed for remote control with various exclusive cords. The Cable Switch A enables you to stand at a distance from the camera and release the shutter by hand. The Remote Cord A connects to the remote terminal of Motor Drive A for both shutter release and automatic film winding. A further remote control possibility is to separate the power unit from the motor drive and use the Power Cord A to connect them.

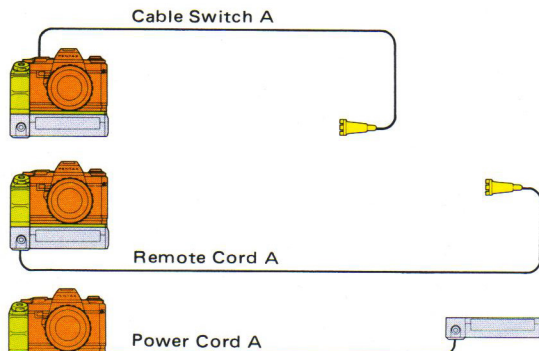

INFRARED REMOTE CONTROL SYSTEM

Simple but sophisticated. 3-channel transmitter for remote control of up to 3 cameras and flash units.

You can control your Super Program from up to 60 meters away by using a compact remote control transmitter. When you press the transmitter's button, it sends infrared pulses to a receiver. The receiver can be mounted on the camera for single-frame operation. It can be connected to a motor drive for continuous shooting. Or you can use three receivers, attach them to three cameras, or three flash units, and control them all from a distance with a single transmitter.

Exciting possibilities

The remote control capabilities of the Super Program open up a number of exciting possibilities. Photographic observation of very timid, or very fierce, animals in their natural habitat. Sports photos from numerous angles or positions along a race course. Studio portraits using multiple flash units while leaving the studio floor free from encumbering cables. Candid shots and surveillance. Scientific studies. Remote control can help you catch otherwise "impossible" images.

Multi-function devices

The transmitter is truly a multi-functional device. In addition to settings for single or continuous shooting, it also has three channels for control of up to three cameras, either simultaneously or individually. The transmitter can also be mounted on the hotshoe of the camera you are holding in your hands. Each time you press the shutter button, the transmitter will send out pulses to control other cameras, or flash units, equipped with receivers.

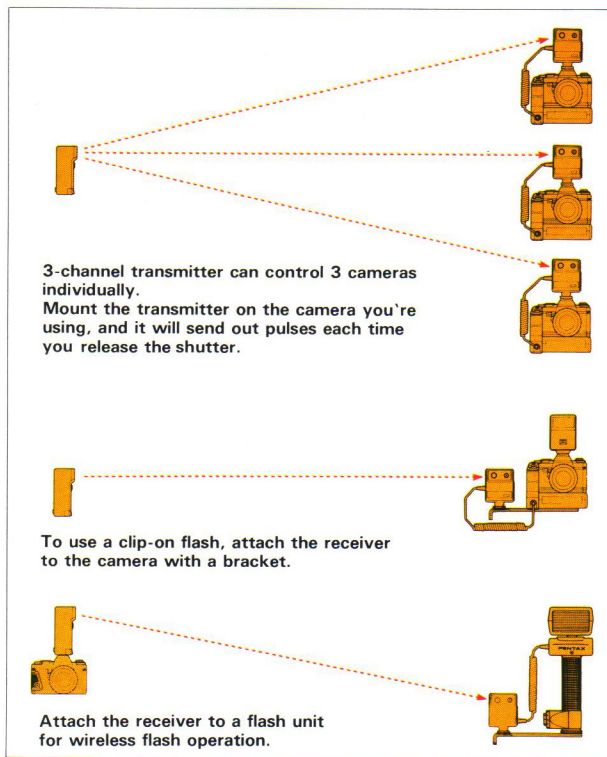

Infrared Remote Control Transmitter (Soon to be released)

Transmission system: Infrared ray pulses.

Number of transmission channels: 3

Modes: C (consecutive shooting), S (single frame shooting)

Transmission interval: Less than 0.7 sec.

Number of possible transmissions: 1,000 times (with fresh batteries)

Max. distance: Approx. 60m in a straight line.

Transmission button: One-touch operation for both C & S modes

Power source: Two 1.5V AA-size Manganese or Alkaline-Manganese batteries.

Other: Transmitter can be mounted in camera hotshoe and will emit pulses when shutter is pressed; transmitter can control multiple units.

Infrared Remote Control Receiver (Soon to be released)

Reception system: Designed exclusively to receive infrared pulses sent by transmitter.

Number of channels: 3

Mode: Selection of C or S automatically controlled by transmitter.

Max. reception distance: Approx. 60m in a straight line.

Power source: One 6V alkaline, silver or lithium battery. Power supply possible from Winder and Motor Drive (Winder ME II, LX, Motor Drive MX, LX and A) using a trigger cord.

Continuous stand-by time: 15 hours (with fresh battery)

Other: 2P trigger terminal provided (used to connect the receiver to camera's electromagnetic shutter release via 2P trigger cord); multiple flash unit operation possible; DIN X terminal provided.

[Soon to be released.]



TTL FLASH UNITS FOR THE SUPER PROGRAM

The Advantages of TTL Auto Flash

When you use a TTL flash unit, flash duration is automatically controlled by an SPD metering cell built into the camera body and positioned to measure the amount of light reaching the film plane. This internal cell measures both ambient and electronic flash light. It assures a proper exposure at any aperture within the electronic flash range and eliminates bothersome calculations for bounce flash, hand-held flash, multiple flash, close-up and macro work. Thus the TTL system allows you to take a wide variety of sophisticated flash photos with ease and guaranteed accuracy.



AF200T

AF200T

This is a very compact and versatile unit designed for general flash photography with the Super Program. It has settings for both TTL and Auto flash, and gives you a choice of two flash ranges, normal and high. In addition to offering fully automatic operation with the camera, it gives you a flash-ready indication in the viewfinder and an audible signal to confirm a proper flash exposure. Guide number 20 in meters, 66 in feet at ASA/ISO 100.

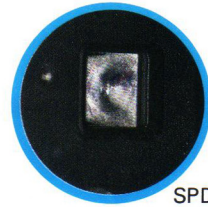
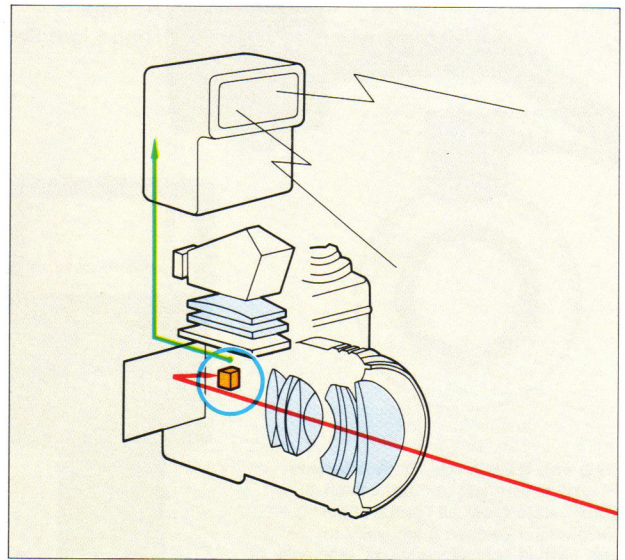

SPD Metering Cell



AF280T

AF280T

This sophisticated flash unit has a wide range of features, including a rotating flash head with 180° horizontal, and 90° vertical settings, plus a -15° setting for close-up work. The AF280T has settings for TTL and Auto Flash, with two flash output levels. You'll find it especially convenient to use the rotating head in the TTL mode. Since flash output is controlled by the film-plane sensor, you can use bounce, angle or close-up flash without any special calculations. Guide number 28 in meters, 92 in feet at ASA/ISO 100.

FLASH ACCESSORIES

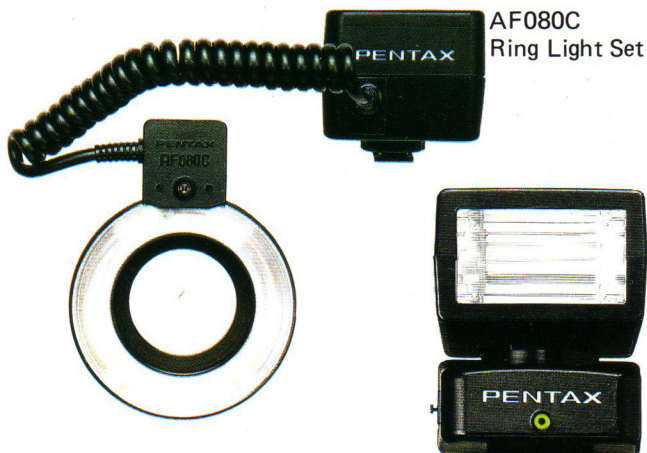

AF080C
Ring Light Set

Tele and Wide-Angle Flash Adaptors

The flash angle of Pentax flash is designed to cover all normal shooting situations. However, if you want to use flash in special situations, telephoto or wide-angle flash adaptors extend your range or angle.

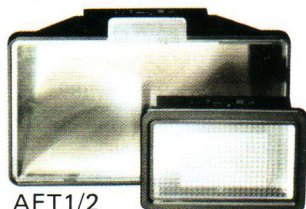

AFT1/2

AFW1/2



AF400T

AF400T

This is a totally professional unit for photographers requiring added power and power source options. A rotating flash head (180° horizontal, 90° vertical and -15° close-up), plus a choice of four power options are among the features of the AF400T. The unit provides TTL Auto Flash and standard Auto with a choice of three power settings. Manual operation with four power settings is also available. Guide number 40 in meters (131 in feet) at ASA/ISO 100.

AF080C

This compact and easy to use Ring Light Set is ideal for close-up and macro-flash. It has a 360° circular flash head that screws directly onto the camera lens, providing shadowless, even illumination for a wide variety of subjects. Because the Ring Light has a TTL setting, you can use it without special calculations. The sensor in the camera body automatically determines the proper flash intensity. Manual operation with two power settings is also provided. Guide number 8 in meters, 26 in feet at ASA/ISO 100.

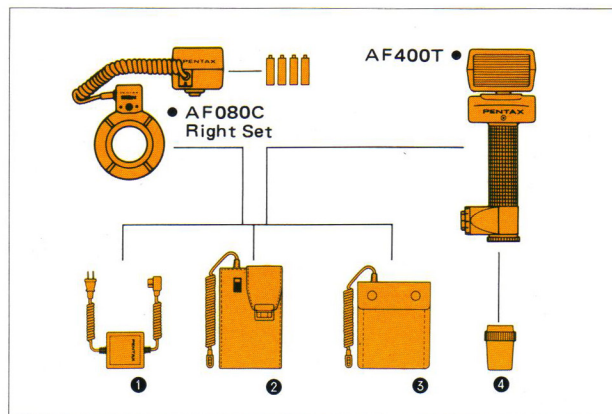

- ① AC Adapter II
- ② TR Power Pack

- ③ Power Pack 510V
- ④ Grip Battery Pack

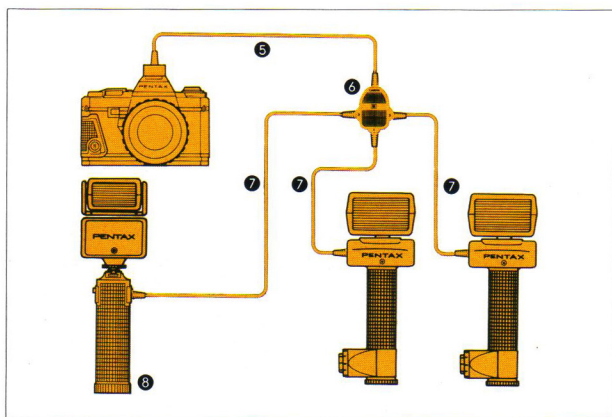

- ⑤ 4P Synch Cord B
- ⑥ Distributor

- ⑦ 4P Multi Cord (5m)
- ⑧ Hot Shoe Grip

DIGITAL DATA M-AUTOMATIC MEMORY



For automatic data-recording on your photos, you'll find that the Digital Data M is an invaluable tool. Designed to interchange rapidly with the Super Program's standard back, the Digital Data M lets you select any of three modes. The first mode prints year, month and day at the bottom of your photo, out of the main picture area. The calendar is accurately programmed up to the year 2019. The second mode prints hour and minute on the frame, while the third mode prints no information, exactly like a standard back. The Digital Data M can be used in all the Super Program's many modes, and with a full range of accessories, including 3.5 frame-per-second motor drive.

82 12 30 [YEAR · MONTH · DAY]

15 - 28 [HOUR · MINUTE]



PROFESSIONAL QUALITY ACCESSORIES

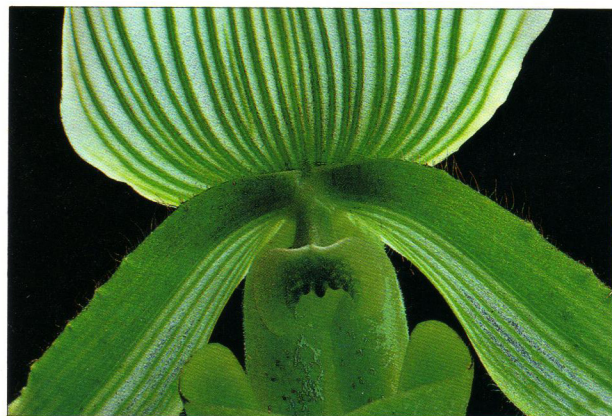

The versatility of the multi-mode Super Program is multiplied by hundreds of high quality accessories in the Pentax system. Whether you're interested in close-ups, macrophotography, photomicrography, remote-control scientific or industrial photography, you'll find that Pentax provides equipment that precisely meets your needs.

For close-ups and copy work, a full array of professional-quality accessories is available, including a choice of auto-bellows or standard bellows units, slide copiers, auto, manual or helicoid extension tubes, plus macrophoto and copy stands, fine-focus adjusters and close-up attachment lenses.

To expand viewing range far beyond the power of the human eye, there are adapters for attaching the camera to a telescope or microscope, as well as a 90° Mirror Adapter for candid shooting and a Stereo Adapter for producing three-dimensional slides.

