

# WILSONWERKS ARCHIVES

This camera manual is for reference and historical purposes, all rights reserved.

This cover page is copyrighted material. This document may not be sold or distributed without the express consent of the publisher.

©2008-2012 wilsonwerks Llc

# SUNPAK<sup>®</sup>

## auto 444 D THYRISTOR

ELECTRONIC FLASH UNIT

Owner's Manual

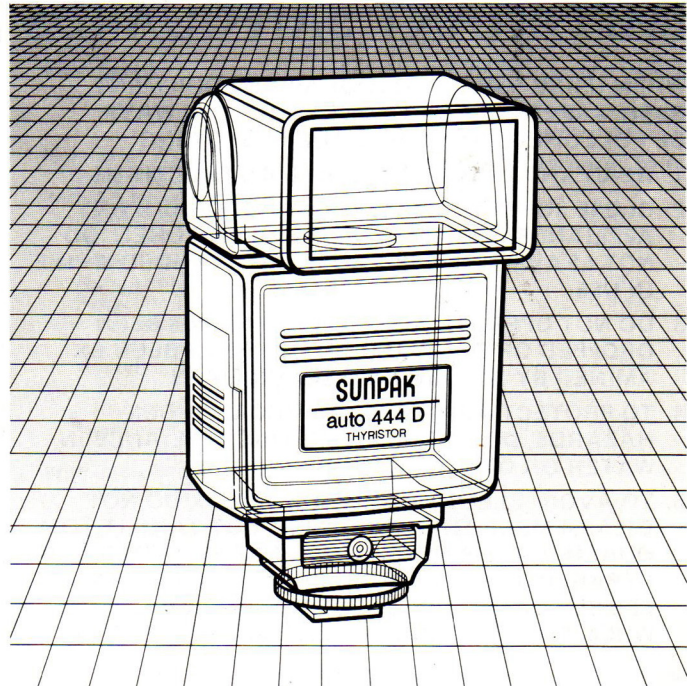

# IMPORTANT SAFEGUARDS

WHEN USING YOUR PHOTOGRAPHIC EQUIPMENT, BASIC SAFETY PRECAUTIONS SHOULD ALWAYS BE FOLLOWED, INCLUDING THE FOLLOWING:

1. READ AND UNDERSTAND ALL INSTRUCTIONS.
2. CLOSE SUPERVISION IS NECESSARY WHEN ANY APPLIANCE IS USED BY OR NEAR CHILDREN. DO NOT LEAVE THIS APPLIANCE UNATTENDED WHILE IN USE.
3. DO NOT OPERATE APPLIANCE IF IT HAS BEEN DROPPED OR DAMAGED-UNTIL IT HAS BEEN EXAMINED BY A QUALIFIED SERVICEMAN.
4. TO PROTECT AGAINST ELECTRICAL SHOCK HAZARDS, DO NOT IMMERSE THIS APPLIANCE IN WATER OR OTHER LIQUIDS.
5. TO AVOID ELECTRIC SHOCK HAZARD, DO NOT DISASSEMBLE THIS APPLIANCE, BUT TAKE IT TO A QUALIFIED SERVICEMAN WHEN SOME SERVICE OR REPAIR WORK IS REQUIRED. INCORRECT REASSEMBLY CAN CAUSE ELECTRIC SHOCK HAZARD WHEN THE APPLIANCE IS USED SUBSEQUENTLY.
6. DO NOT OPERATE APPLIANCE WITH A DAMAGED CORD.
7. DO NOT LET CORD HANG OVER EDGE OF TABLE OR COUNTER OR TOUCH HOT SURFACES.
8. IF AN EXTENSION CORD IS NECESSARY, CARE SHOULD BE TAKEN TO ARRANGE THE CORD SO THAT IT WILL NOT BE TRIPPED OVER OR PULLED.
9. ALWAYS UNPLUG APPLIANCES FROM ELECTRICAL OUTLET WHEN NOT IN USE. NEVER YANK CORD TO PULL PLUG FROM OUTLET. GRASP PLUG AND PULL TO DISCONNECT.

**SAVE THESE INSTRUCTIONS**

# Introduction

WELCOME to the world-wide family of Sunpak owners. Your Sunpak auto 444 D is one of the most advanced electronic flash units in the world. It is the product of extensive research and development and has been designed to give you many enjoyable years of service. Because many of the fine features of your new auto 444 D are so unique, please take a few minutes to read this owner's manual carefully with your auto 444 D in front of you. The more you know about your new electronic flash, the better you can use it for maximum creativity in your pictures.

## Condensed Operating Instructions for Automatic Operation

(In case of use with standard camera.)

---

1. Set the ASA for the film in use.
2. Set the Auto/Manual Selector Switch so that the red, green or yellow "A" appears.
3. Move the On/Off Switch to the "BATT." position.
4. Wait for the Ready/Test amber light to glow.
5. Set the aperture on your camera to the corresponding aperture which is displayed in the computer f/stop window. You are now ready to take your pictures.

\* When using the Sunpak auto 444 D with the cameras that offer dedicated electronic interfacing, refer to the Interface Module instruction leaflet.

---

## Table of Contents

Description of Parts . . . . .	4
Unique Features of Auto Thyristor 444 D Flash . . . . .	6
<b>OPERATION</b>	
Power Sources . . . . .	8
To Install Batteries . . . . .	9
Using the Multi-Voltage AC Adapter or the Sunpak Powerpak for 510-Volt (High Voltage) Battery . . . . .	10
Mounting the Flash to the Camera . . . . .	11
To Change the Module . . . . .	11
<b>OPERATION OF THE POWER/EXPOSURE CONTROL CENTER</b>	
<b>(Operating Instruction for Standard Cameras)</b>	
Automatic Operation . . . . .	12
Taking the Picture . . . . .	14
Power Ratio (Manual) Operation . . . . .	15
Using Power Ratio for Better Pictures . . . . .	17
Operating Adjustable Bounce Flash Head . . . . .	21
Off-Camera Flash . . . . .	22
For Better Bounce Flash Pictures . . . . .	23
Copy Photography . . . . .	26
Hints for Taking Photographs Using a Copy Set-Up . . . . .	27
Other Flash Hints . . . . .	28
Multiple Flash Operation . . . . .	29
Accessories Available for the Sunpak auto 444 D . . . . .	32
Inside Your auto 444 D . . . . .	36
Care of Your auto 444 D . . . . .	37
Guide Number and "Flashmatic" Camera Operation . . . . .	38
Specifications . . . . .	39

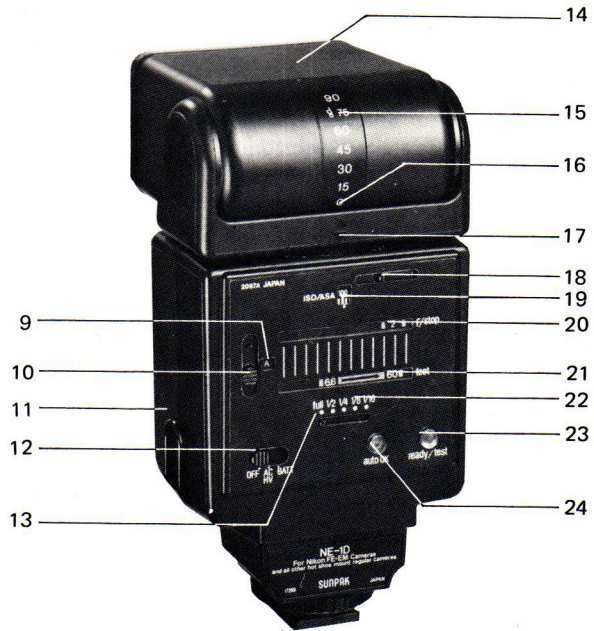
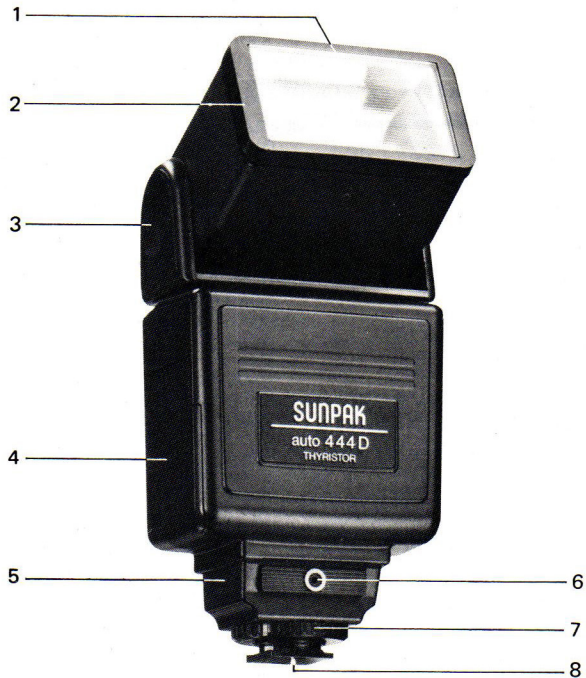

# Description of Parts

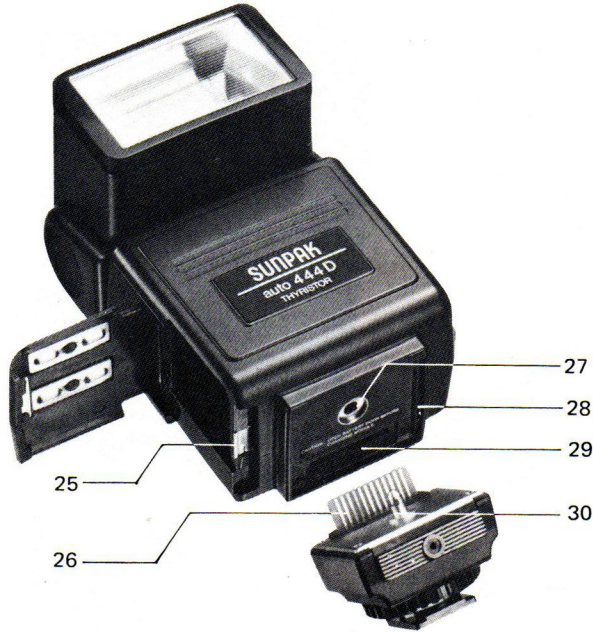

1. Flashtube, Reflector and Lens
2. Accessory (optional) Mounting Guide
3. Bounce Flash Control Base
4. Battery Compartment Cover
5. Interchangeable Interface Module
6. Auto Sensor
7. Knurled Lock Ring
8. Dedicated/Hot Shoe Contact
9. Auto/Manual Mode Window
10. Auto/Manual Selector Switch
11. AC/510V Socket
12. Battery/AC.HV Selector (On/Off) Switch
13. Power Ratio Selector
14. Bounce Flash Head
15. Bounce Flap (built-in the Tele Kit) Position Indicator
16. Vertical Bounce Control Scale
17. Bounce Angle Indicator
18. Film Speed Selector
19. Film Speed Indicator Window (ASA)
20. F/Stop Scale
21. Distance Scale
22. Power Ratio Control Scale
23. Ready Light/Test (Open Flash) Button
24. Auto OK Indicator
25. Interface Module Locking Lever
26. Interface Blade
27. Interlock Receptacle
28. Interface Module Positioning Guide
29. Interface Receptacle
30. Interface Module Locking Pin

# Unique Features of the Auto Thyristor 444 D Flash

## ● MULTI-INTERFACING MODULES . . .

One Flash for All Dedicated Camera Systems: By using Sunpak's unique interchangeable modules, which are available as optional accessories, your auto 444 D will interface with many dedicated cameras. It is so simple that all you have to do is to select one of the Sunpak\*Interface Modules specifically designed for the camera you are using and mount it on your auto 444 D.

● **QUICK . . .** Full camera dedication with full electronic interfacing. Set not only the 'X' sync, but much more.

### **Interface Module:**

- Total Dedicated Circuitry
- Built-in Hot Shoe Contact
- Standard Operation

Perfect coupling for today's 35mm Electronic SLR cameras

### **Standard Shoe: (optional)**

- Built-in Hot Shoe and Auto Sensor

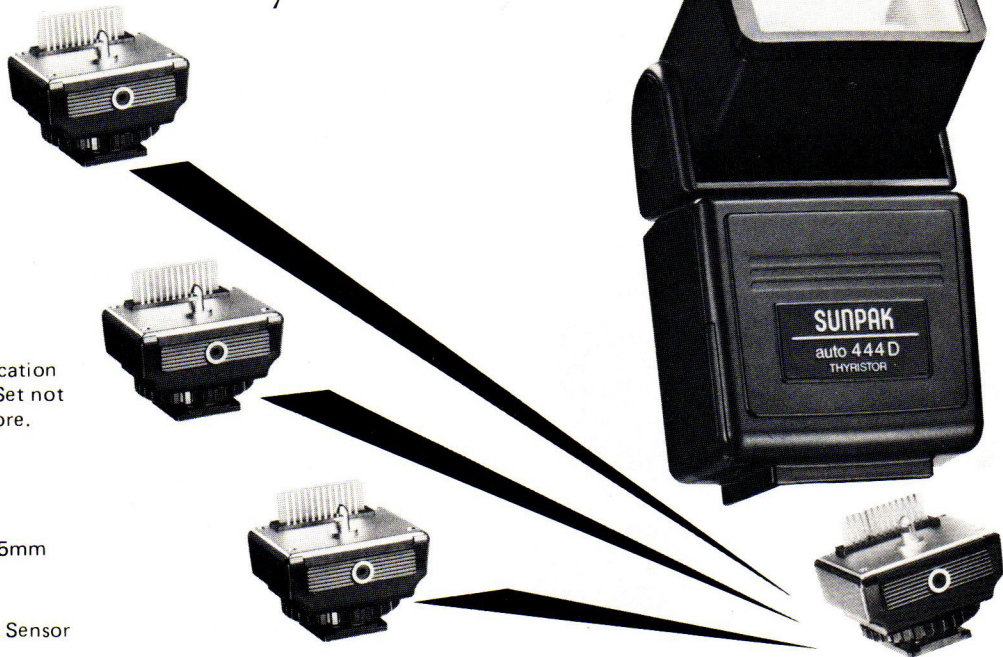

### ● MULTI-BOUNCE . . .

The flash head can be aimed virtually in any direction. The head has 330 degree rotation and 90 degree elevation. No matter where the flash head is aimed, the Built-In Auto Sensor faces the subject for total automatic exposure control.

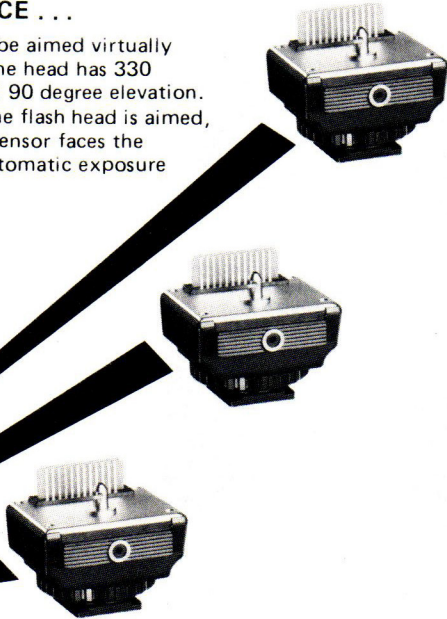

### ● INSTANT READOUT EXPOSURE CONTROL CENTER . . .

Displays only the actual f/stop in use along with the Auto Distance Range. Quick and Easy operation makes flash operation simple.

### ● BUILT-IN POWER RATIO CIRCUITRY . . .

Provides maximum creative control, for close-ups, action freezing, rapid sequence photography, depth-of-field control, fill-in flash, and multiple lighting setups.







# Operation



## POWER SOURCES:

Your Sunpak auto 444D may be used with five different power sources:

		
Four AA alkaline batteries (not included)	Four AA rechargeable nickel-cadmium batteries (optional)	The Sunpak Multi-Voltage AC Adapter (AD-27) (optional)
		
The Sunpak Powerpak for 510-Volt (High Voltage) Batteries (optional)	The Sunpak 510V rechargeable battery NC510 (for use with Sunpak Powerpak) (optional)	

## To Install Batteries:

### Alkaline or Nickel-Cadmium Batteries?

The major advantage of alkaline batteries is that they provide more flashes per set. While nickel-cadmium batteries will provide fewer flashes per set, they will recycle your auto 444 D slightly faster and can be recharged hundreds of times for more economical operation over the long run.



1. Slide the battery compartment cover toward the bottom of the unit. Now gently fold up the cover in the direction shown.

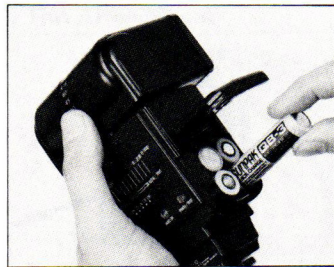

2. Insert four AA size batteries (alkaline or nickel-cadmium) as shown. The battery compartment has a guide showing the correct positioning of the batteries for proper polarity. (+, - contacts).

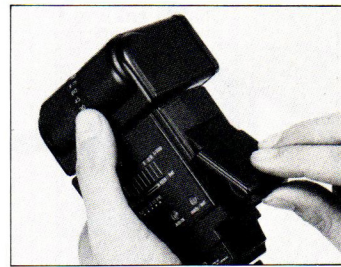

3. Press the cover until it snaps into place.

## Using the Optional Multi-Voltage AC Adapter or the Optional Sunpak Powerpak for 510-Volt Batteries

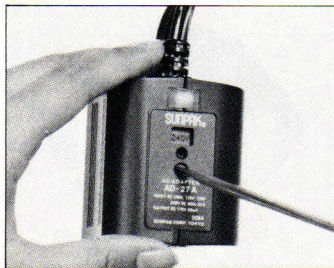
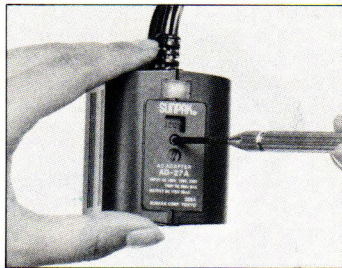

1. For AC operation, be sure to check that the voltage selector on your Multi-Voltage AC Adapter is set to the appropriate voltage. Your AC Adapter has been factory set for 117V, the U.S. standard. For use in other countries where 127V, 220V and 240V are standard, you may adjust the setting as illustrated. Remove the small Phillips head screw located next to the voltage

window and rotate the selector switch with a screw driver to the proper voltage setting. After the voltage setting has been made, the screw must be reinstalled to prevent accidental movement of the selector switch.

**Note:** If the Multi-Voltage AC Adapter is incorrectly set, the adapter will not function properly and may damage your auto 444

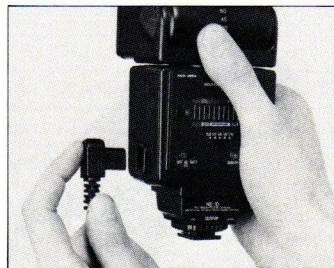

2. Insert plug into the AC/High Voltage socket on the flash and into a standard wall outlet as illustrated. The AC Adapter will supply virtually unlimited flashes and is ideal for indoor use.

**Note:** When using the Multi-Voltage AC Adapter or the Sunpak Powerpak for 510-Volt Batteries, always set the Battery/AC HV Selector Switch to the AC/HV position.



3. When you use the optional accessory Sunpak Powerpak for 510-Volt Battery, first attach the supplied plug adapter to the end of Powerpak cord and plug it into the auto 444 D in the same manner as you would with the Multi-Voltage AC Adapter. The Sunpak Powerpak for 510-Volt Battery allows extremely rapid recycle times and the greatest number of flashes.

**CAUTIONS:** Even when your auto 444 D is used with external power sources, always store batteries inside for dedicated function. Your auto 444 D is not interfaced to the camera without internal batteries.

## MOUNTING THE FLASH TO THE CAMERA:

**CAUTION: WHEN MOUNTING OR DETACHING THE auto 444 D THYRISTOR FROM YOUR CAMERA, ALWAYS MADE SURE THAT THE ON/OFF SWITCH IS SET AT THE "OFF" POSITION OR THE CAMERA MAY BE DAMAGED.**

1. Slip the unit onto the camera's hot shoe. Turn the knurled lock ring clockwise to insure secure mounting to your camera's shoe.

**Note:** When using Olympus cameras, make sure that the appropriate accessory shoe as below is attached to your camera and then put the auto 444 D on it.

- For OM-2N, OM-1N: accessory shoe #4
  - For OM-2: accessory shoe #3
  - For OM-10: mount the auto 444 D onto the built-in hot shoe.
2. If your camera does not have a hot shoe contact, use an optional Standard Shoe (Cat. No. 651-042) and optional Flash Synch Cord (Cat. No.651-781).
    - A. Insert the male end of the synch cord into the socket on the base of Standard Shoe.

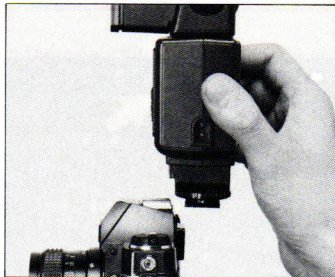

- B. Connect the other end to the flash synch socket on your camera (usually marked 'X'). In case your camera has no 'Accessory Shoe', use the optional Sunpak Basic Grip (Cat. No. 651-772).
3. Set the Camera shutter to the fastest shutter speed synchronized for electronic flash. For SLR cameras, the highest usable speed is generally 1/60th second; however, some permit flash synchronization of up to 1/125th second. To be sure, refer to your camera's instruction manual and the Interface Module instruction manual.

## To Change the Module:



Your Sunpak auto 444 D is so designed that by changing its interface module (a hot shoe contact) the flash will be fully interfaced with any dedicated camera. (For details of the Interface Modules, please read the separate instruction leaflet for the interface modules.)

1. Open the Battery Compartment Cover and take out the batteries.
2. Pull the Interface Module Locking Lever out with a metal piece like a coin as illustrated.
3. Remove the Module while holding the Locking Lever out.



4. Insert the Interface Blade and the Locking Pin of the module respectively into the Interface Receptacle and the Interlock Receptacle of the flash body. Then push the Locking Lever back into the locking position until the edge of the marks align. Make sure the module is securely attached.

**CAUTION: THE BATTERY COMPARTMENT DOOR MUST BE OPENED PRIOR TO ATTACHING OR DETACHING INTERFACE MODULES.**

# Automatic Operation

## OPERATING INSTRUCTIONS FOR STANDARD CAMERAS

### Operation of the Power/Exposure Control Center

The sensitive silicon photo transistor of your auto 444 D sensor located in the interface module measures the light reflected from the subject and automatically regulates the flash duration providing correct exposure within a wide range of distances. It's easy to use:

**Note:** The operation of the Sunpak 444 D slightly differs depending on the camera in use.

- When used with its exclusive SLR camera: Refer to the interface module instruction manual for details.
- When used with other ordinary cameras: Follow the operating instructions on this page. Refer to the camera instruction manual for operation of the camera.

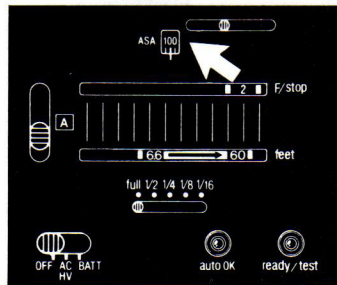

A. Slide the ASA Film Speed Scale until the ASA of the film in use is visible in the ASA speed window. (Example: ASA 100).

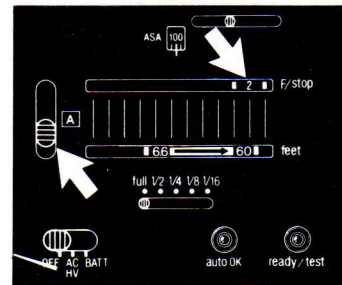

B. For the maximum distance range in automatic operation, move the Auto/Manual Selector Switch to the green "A" position so that the green "A" is visible in the Auto/Manual Mode Window. A Green line and f/2 will appear. Then set your camera lens opening (for ASA 100 film, the lens opening is f/2). Your flash and lens are now set for correct exposure at any distance between 6.6 feet and 60 feet.

**Note:** If the ASA number for your film is not indicated on the ASA film speed scale, use an intermediate markings as shown.

Marked ASA Speeds:	1000		400		200		100		50		25
Intermediate Nos:	800	640	500	320	250	160	125	80	64	40	32

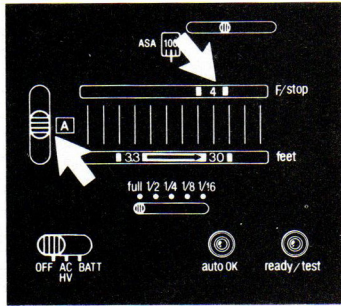

C. For an intermediate distance range in automatic operation, move the Selector Switch to the yellow "A" position so that the yellow line and f/4 appear. Then set the same aperture on your camera (for ASA 100 film, the lens opening is f/4). Your flash and lens are now set for correct exposure at any distance between 3.3 and 30 feet.

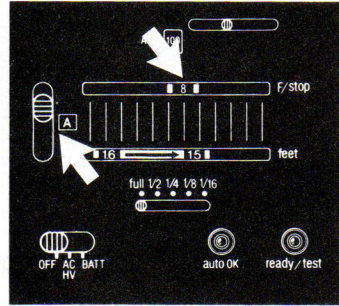

D. For maximum depth-of-field (greatest sharpness in front of, and in back of the subject), move the Selector Switch to the red "A" position so that the red "A", the red line and f/8 appear.

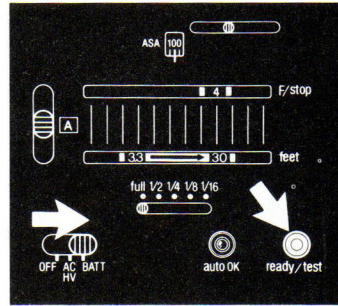

Then set your camera lens opening (for ASA 100 film, the lens opening is f/8). Your flash and lens are now adjusted for correct exposure at any distance between 1.6 and 15 feet.

# Taking the Picture

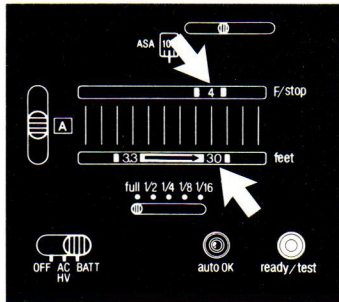

1. Move the Batt/AC HV Switch to the appropriate position for your power source.

2. In a few seconds, the Ready/Test Button on the back of the flash unit will start to glow. This confirms that your flash is ready to fire.

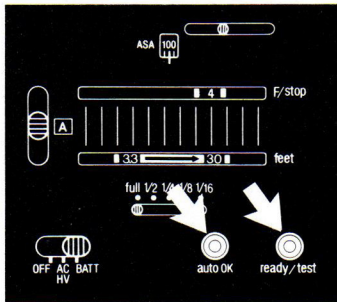

3. **Take the picture!**  
Your flash will automatically provide the correct amount of light for proper exposure within the distance range indicated. **For succeeding exposures . . .** Just wait until the Ready/Test light comes on. Make sure you are within the usable auto distance range for the lens opening in use and . . . Shoot!

## To Verify Correct Auto Exposure:

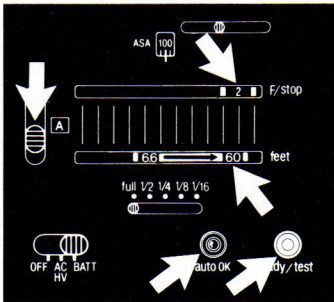

To verify the correct automatic exposure, just aim your flash directly towards your subject and press the Ready/Test Button. This will cause the flash to fire without actually exposing any film. If the automatic exposure is correct for your subject, the green "Auto OK" lamp will glow immediately after the "test" exposure.

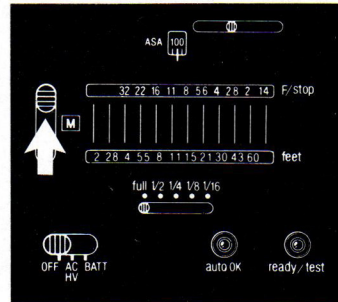

If the lamp does not glow, move closer to your subject (or, if you are shooting in yellow or red auto mode, switch to green and adjust the aperture accordingly.). The 'Auto OK' provides positive verification in automatic operation that your picture will be correctly exposed.

# Power Ratio (Manual) Operation

With Sunpak's unique Power Ratio Control you can adjust the light output over a five stop range (from full to 1/16 power). This feature gives you greater depth-of-field control, the ability to control battery life and recycle times, precise fill-in flash capability, macro/close-up capability and the ability to control flash duration.

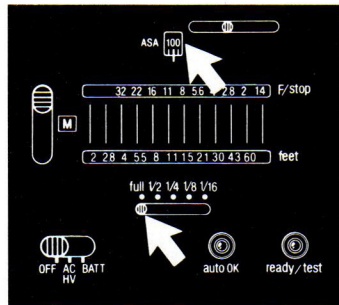

1. Set the Auto/Manual Selector Switch (on the back of the flash body) to the top so that the white "M" appears.

## OPERATING INSTRUCTIONS FOR STANDARD CAMERAS

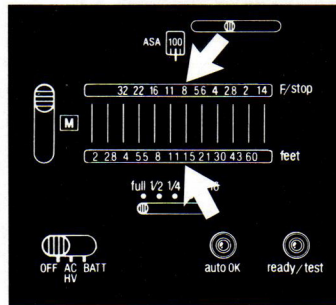

2. Set the Film Speed Scale to the desired ASA setting. (Example: ASA 100).
3. Adjust the Power Ratio Control to full power by sliding the Selector Switch.

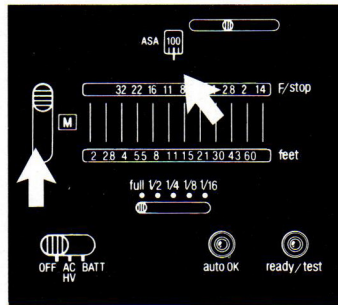

4. The scales for distance and f/stop now show the correct combination of exposure. Find the flash-to-subject (not camera-to-subject) distance. (Example: 15')
5. Set your lens to the lens opening shown for this distance. (Example: with ASA 100 film, the correct lens opening at 15' is f/8).

## Using the Power Ratio Control at Full Power:



## Using Power Ratio:

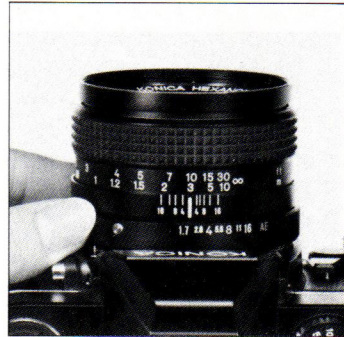
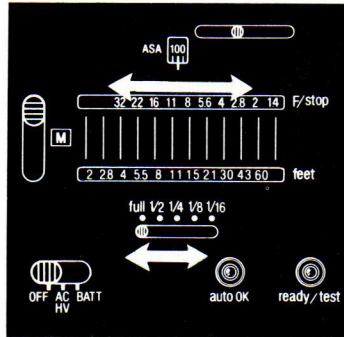
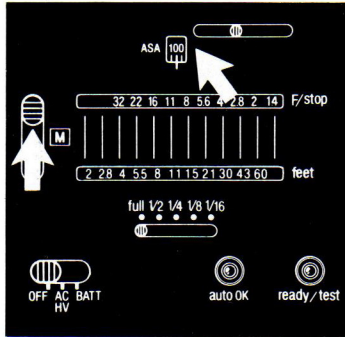

1. As when using the Power Ratio at full power, set the Film Speed Scale to the appropriate ASA rating and be sure the Auto/Manual Selector is at "M".
2. Determine the distance of your subject from your flash. When the auto 444 D is mounted onto the camera, focus your camera's lens and read the distance indicated by the distance scale on the lens barrel.
3. Slide the Power Ratio Control Switch until you have the desired f/stop opposite to this distance. ALWAYS SLIDE THE POWER RATIO CONTROL SWITCH TO A MARKED (CLICK STOP) POSITION. DO NOT SET THE POWER RATIO BETWEEN MARKED POSITIONS OR THE UNIT WILL NOT OPERATE AS DESIRED. (Example: 11 feet with ASA 100 film, you may choose f/11, 8, 5.6, 4 and 2.8.).
4. Be sure the distance scale indicates proper f/stop for the correct exposure of your subject. If not, increase or decrease the power as needed.
5. You are now ready to take your picture. Remember to adjust the aperture on your lens to match the aperture indicated on the calculator scale.

## USING POWER RATIO FOR BETTER PICTURES

### Fill-in Flash Photography

Your Sunpak auto 444 D electronic flash is of significant benefit even in outdoor photography. Example: a bright day at the beach . . . much too bright for your subjects to face the sun. So you turn them around, and shoot against the sunlight: a backlit shot. You can take a close-up meter reading of their faces, to insure that the exposure is based upon the subjects' faces (relatively dim) and not upon the background light (extremely bright). While this technique will produce a well-exposed image of the subject, the background will be rendered far too light; the brightness value in the scene is beyond the ability of any film to record.

**Solution:** Sunpak auto 444 D . . . and its unique Power Ratio Control.



#### EXAMPLE:

Full fill-in (1/2 power)  
Shutter speed: 'X' speed  
Distance to subject: 11 feet  
Film speed: ASA 100  
Aperture: f/8

- 1) With your camera's built-in exposure meter (or a separate meter), determine and set the correct lens opening for the brightest part of the scene when exposed at the fastest speed at which your camera synchronizes with electronic flash. (Automatic shutter-priority cameras, such as Konica may be used in "Automatic" mode.)  
Example: Set your camera's shutter to 'X' speed (or to the fastest speed synchronized for electronic flash without exceeding 1/700th second). Your meter indicates correct exposure for the brightest area of the scene — usually the background. Example: Set your lens to f/8.
- 2) Focus, and read the camera-to-subject distance (feet) from your lens' distance scale.  
(**Example:** 11 feet.)
- 3) You have now determined the two required parameters for correct exposure — aperture and distance. Move the Power Ratio Control Selector until the required distance (11') appears above the required aperture (f/8). Your flash will now operate at the correct power ratio setting for perfectly-balanced fill-in flash.  
Example: Where an aperture of f/8 is required at a distance of 11 feet, a "power ratio" of 1/2 is set for ASA 100 film.
- 4) Shoot! Your picture will be perfectly exposed, because the light of the flash on your subject is now balanced perfectly with the exposure required for the brightest part of the scene!



Full fill-in (1/2 power)

The technique described above provides equal brilliance on the subject and the brightest area of the overall scene. This effect is called "full" fill-in and gives excellent results with a majority of subjects.



1/2 fill-in (1/4th power)

- Should you prefer a less pronounced fill-in effect (less light on subject), move the Power Ratio Control to the next smallest position: for example, 1/4th when 1/2 is indicated. Use this technique when your subject is surrounded by a faint shadow or has an unusually light complexion or appearance.

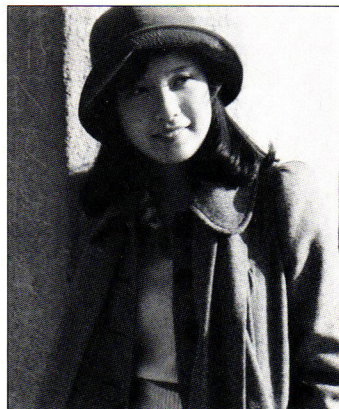

1/4 fill-in (1/8th power)

- Alternatively, you may wish to employ a more pronounced fill-in flash effect when your subject has darker complexion or is in an extremely dark shadow and not well lit as other bright areas of the scene. This "extra" fill-in effect is achieved simply by dialing



1/8 fill-in (1/16th power)

- Experiment, when possible, to determine the ratio most pleasing to you with subjects representative of your normal picture-taking.

## Depth-Of-Field Control

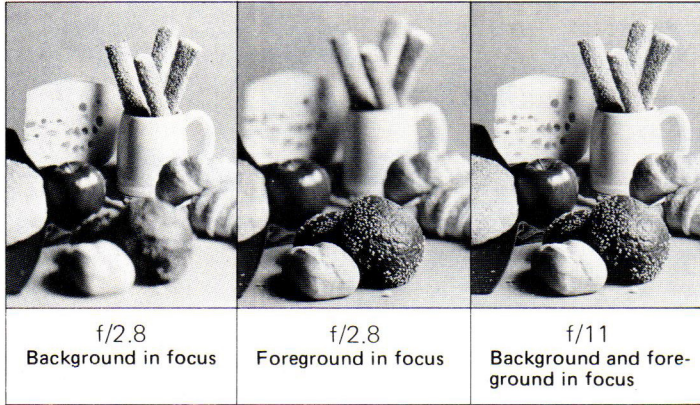

In addition to controlling the exposure, the lens opening or the lens aperture, the Power Ratio Control also regulates the depth-of-field of your image. When a lens has a small aperture, such as  $f/16$  or  $f/11$ , the area in front of and behind your subject will be in focus. However, when the lens aperture becomes wider, such as at  $f/2.8$  or  $f/2$ , the area in focus will be significantly reduced. Thus, when you use a wider aperture, your portraits will be more pleasing because distracting backgrounds will be all but eliminated. For other subjects, such as still life, you will want the entire area to be in focus. With the Sunpak Power Ratio Control, you can adjust the power ratio setting to the aperture you desire for extra creative control.

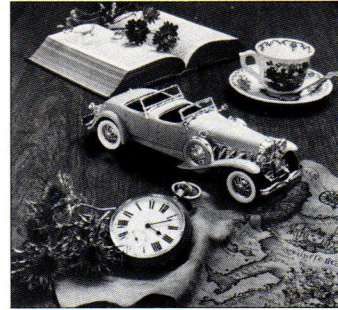

### Examples:

When photographing still life, more depth-of-field is often required. Use the higher power settings and smaller lens openings for best results.

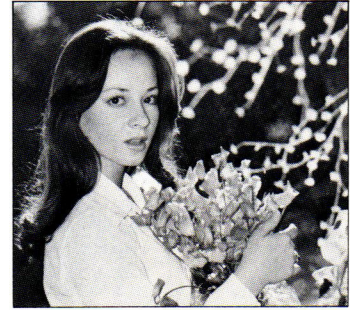

For portraits, use the lower power settings and larger lens openings for less depth-of-field.

## Freezing Action

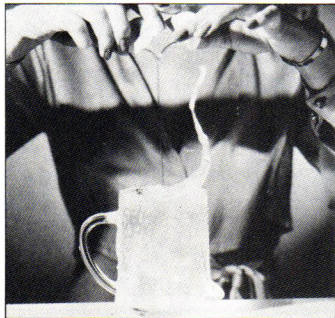

Your auto 444D can freeze almost any action at full power with a flash speed of just 1/700th second. For even briefer flash duration, which will allow freezing of the fastest action, you can use the Power Ratio's lower settings to obtain speeds as fast as 1/10000th second.

## Working With Motor Drive/Auto-Wind Cameras

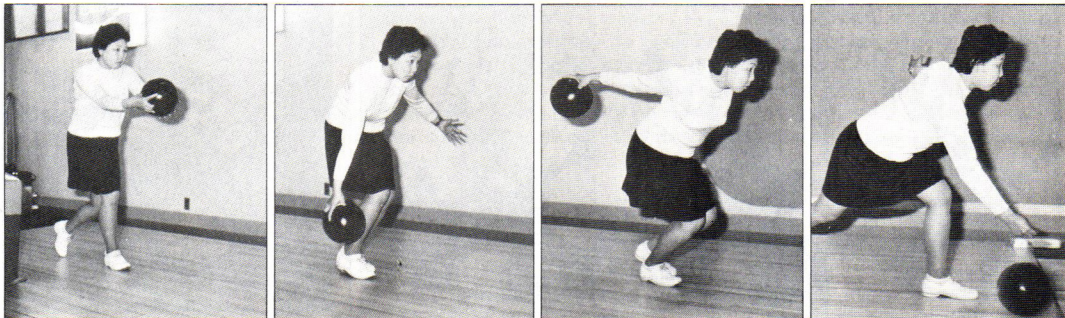

By using the 1/16th Power Ratio setting, far less energy is expended with each flash and the auto 444D will recycle almost instantly.

With fresh batteries, you can shoot up to three pictures per second, thus making the auto 444D ideal for use with motor-drive and auto-wind cameras.

- \* For motor drive operation, the Sunpak Powerpak for 510-Volt Battery (Cat. No. 651-723) will provide the best results. (You can shoot up to four pictures per second.)
- \* Note: When taking up to 40 frames continuously, rest the flash unit for 10 minutes or more.

Power Ratio    Flash Duration

Full	1/700th sec.
1/2	1/1200th sec.
1/4	1/3000th sec.
1/8	1/6000th sec.
1/16	1/10000th sec.

# Operating Adjustable Bounce Flash Head

Your auto 444 D has a unique flash head assembly which enables you to aim the light in virtually any direction and render more pleasing and creative results.

For added convenience and repeatability, the Adjustable Bounce Flash Head has reference marks so you can determine the exact angle of bounce you desire.



1. To rotate the Adjustable Bounce Flash Head, grip with thumb and forefinger and gently turn to the desired setting.  
**DO NOT FORCE THE HEAD.**



2. To adjust the Flash Base, simply twist as illustrated with thumb and forefinger.
  - For a complete description for better bounce pictures please read Sunpak's "Guide to Electronic Flash Photography".

## WIDE ANGLE LENSES:

auto 444 D	Without Diffusion Filter	With Diffusion Filter 28	With Diffusion Filter 20
Angle of Illumination (on 35mm camera)	35mm lens	28mm lens	20mm lens
Guide Numbers (ASA 25)	60	42	30

For best results when using moderate wide-angle lenses with direct flash, such as a 35mm focal length lens with a 35mm camera, be sure to adjust the bounce flash head to match the format of the film. For other wide-angle lenses, use the diffusion filters (included in the Sunpak Filter Kit Cat. No. 651-738) or bounce lighting may also be used for maximum flash coverage.

## TOTAL BOUNCE CONTROL SYSTEM:

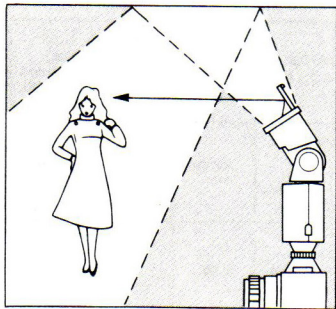

In addition to its bounce flash head, your auto 444 D's unique accessories are ideal for better bounce lighting.

### Bounce Flap:

The bounce flap gives multiple lighting effects. A predetermined portion of light illuminates your subject directly and the rest of the light bounces to the ceiling. Ideal for vivid and lively effects. (Built-in the optional accessory, Sunpak Tele Kit TL-8 Cat. No. 651-842).

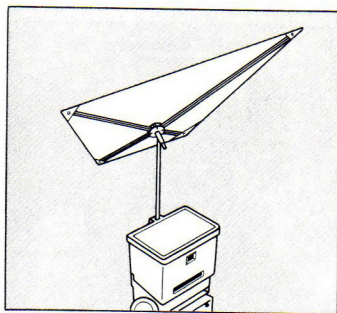

### Bounce Lighting Kit:

For more extensive bounce lighting effects, Sunpak Bounce Lighting Kit Cat. No. 651-795 (to be attached to the Sunpak Tele Kit TL-8 or Filter Holder) is available as an optional accessory. For details, refer to the Bounce Lighting Kit instruction manual.

## OFF CAMERA FLASH

Off-camera flash offers many of the benefits of bounce flash. In addition, it allows the full power of the flash to be used, thus permitting professional lighting effects (and smaller lens openings) irrespective of distance or ceiling reflectance. It's easy to use.

### Off-Camera Flash By Extension Cord:

1. Detach the Interface Module from the flash body and slip it onto the hot shoe of your camera.
2. Just connect the flash body and the Interface Module by the Sunpak Dedicated Remote Cord (optional). For details refer to the Dedicated Remote Cord instruction leaflet.
3. Set the flash to the "Auto" position, and adjust the camera lens to the f/number indicated in the f/stop Scale.
4. **Take the picture!**

Your flash will measure and deliver the exact light required for your subject . . . and the highly directional lighting will provide excellent illumination. Since the flash is aimed towards your subject off the optical axis, shadows will be directed away from the subject out of the picture area.

It's a basic professional lighting technique . . . made easy by your Sunpak's unique Quick-Release Interface Module System!

## FOR BETTER BOUNCE FLASH PICTURES

### Don't Stand Too Close to Your Subject.

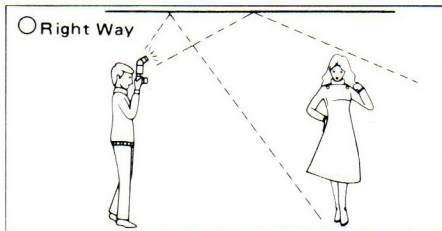
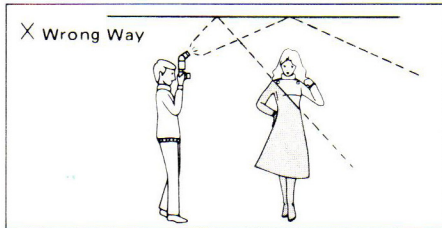

Reason: The light will be reflected downward at an angle so acute that no light (or very little light) can reach your subject's face. This will cause unpleasant looking dark (shadow) areas under the subject's eyes and nose.

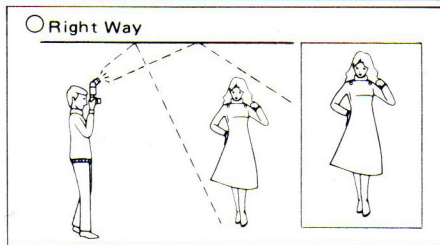
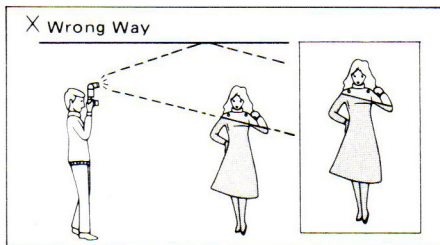

Rotate the flash sufficiently to prevent the subject or the background immediately behind the subject from receiving any portion of direct light from the flash.

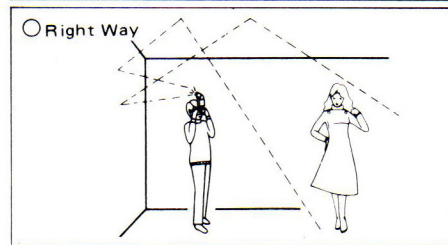
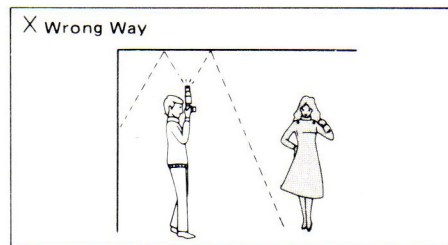

In small rooms, try bouncing the light off the wall onto the ceiling. Provided it is a white wall and ceiling, this technique provides more even lighting than off-ceiling bounce where space is limited.



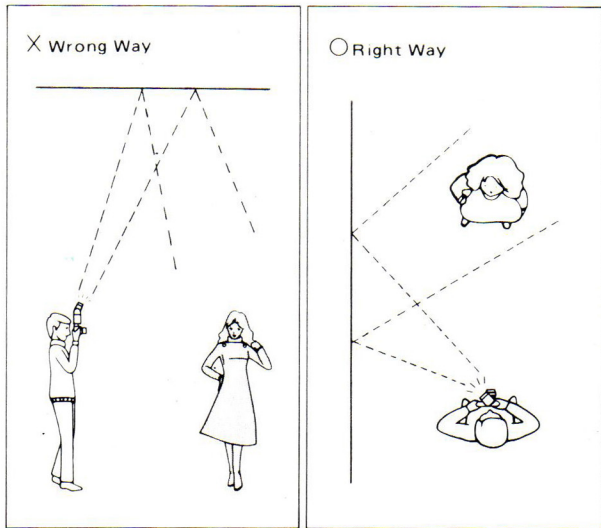

Remember, you can bounce light off a wall if the ceiling is too high. In many homes, a white wall makes an excellent reflective surface for bounce flash ... and, quite often, more light can reach the subject since the light does not have to travel as far.

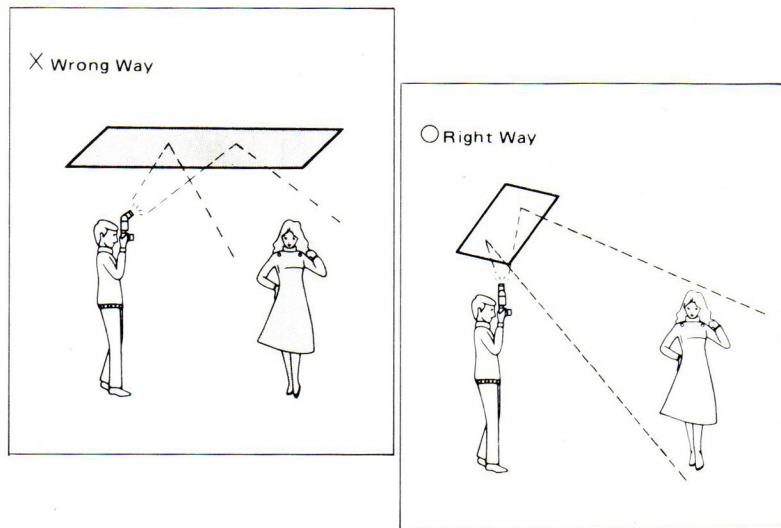

If you can't find a suitable bounce surface, you can make one, i.e., if the wall or ceiling is any color other than white, your subject will show that color in the finished photograph. Therefore, create your own bounce surface ... possibly you can use an ordinary piece of white cardboard held or taped in front of the flashtube housing so that it reflects the light onto the subject.

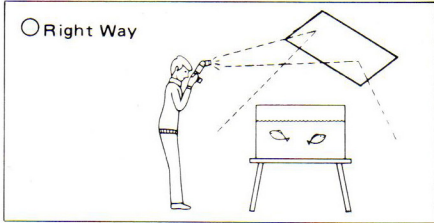
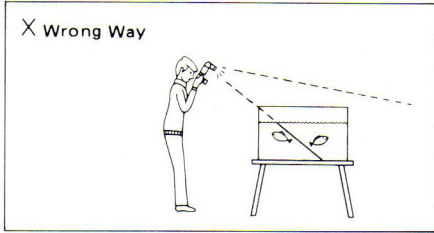

In close-up photography, many excellent lighting effects can be achieved by using one or more pieces of white cardboard as reflective surfaces in bounce flash. The soft, diffused effect of "bounce" light often reveals fascinating details of small objects.

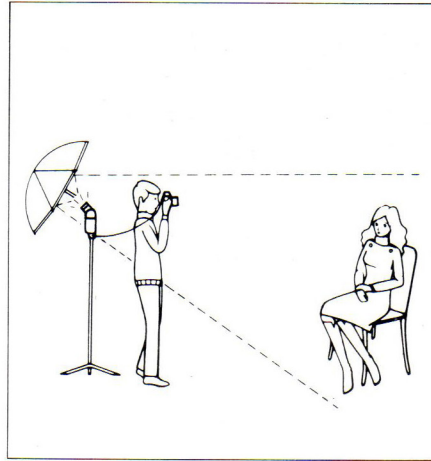

For extensive use in portrait photography, many photographers prefer "umbrella" lighting created by bouncing the flash off a white or silvered umbrella. The Sunpak Bounce Lighting Kit is ideal for this use.



**NOTE:** To determine the bounce lighting technique which satisfies you, try experimenting by using all of the flash head positions.

# Copy Photography

Because of its unique Power Ratio Control, your auto 444 D is ideal for copy photography. By adjusting the power you can control the auto 444 D's light output, which is critical with relatively short flash-to-subject distances.

For copying, you can use a copy stand, modified enlarger baseboard and girder or a tripod which can have its pan head mounted to the bottom of the center column. In addition, you can use one, two or four auto 444 Ds.

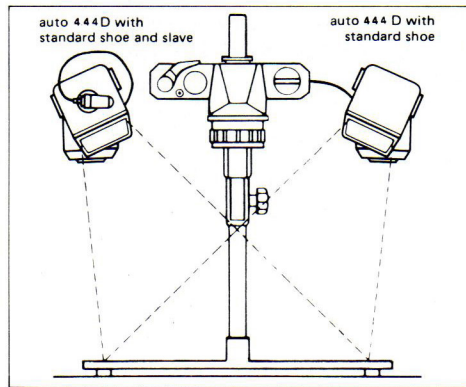

## Copy Photography: Practical, Fun and Quick

- \* **Hobbies:** You can reproduce stamps, coins, seashells, butterflies, plant life and other items.
- \* **Vital Documents:** Diplomas, birth certificates, cancelled checks, licenses, etc.
- \* **Charts:** You can keep a photographic record of any charts or graphs you prepare for school or business. In addition, color transparencies of the charts can be made for slide presentations.
- \* **Valuable Possessions:** Items such as jewelry, silverware and works of art can be photographed and used for insurance purposes.

## A TYPICAL COPY SET UP FOR DOCUMENTS

1. An ideal set-up for shadow-free copies; take two auto 444 D's, one connected to your camera, another to the Sunpak Auto Slave, aimed at a  $45^\circ$  angle to the subject on the same axis as the camera. As the illustration shows, twice the normal amount of light is hitting the subject, so you should either close down the lens aperture by one stop (two stops when using four units) or adjust the Power Ratio Control by half the Power Ratio setting (-1 stop).  
**Note:** To mount the auto slave to auto 422 D, first attach the standard shoe to the 444 D and connect the auto slave and the standard shoe with PC cord.
2. If you own another electronic flash unit, you can use the Power Ratio Control on your auto 444 D to set the unit at a similar power level as the other unit. Simply match the guide number from the specification chart on page 38 with the appropriate power level to your other unit.

# Hints for Taking Photographs Using a Copy Set-Up

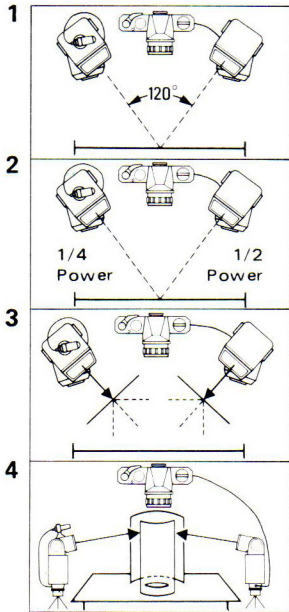

1. When photographing a three-dimensional subject, such as a coin, try setting the flash units at a  $120^\circ$  axis from the lens. This is also excellent for subjects with an irregular flat surface such as an oil painting, and high gloss subjects. For best possible results, experiment with different angles until you get the results you like.
2. For showing shadow and texture on a three-dimensional subject, use your auto **444D** at different power levels. Again, experimentation is the best way to discover what is the best lighting ratio between the auto **444D** for the subject you are copying.
3. For a softer lighting effect, fire the **444D** through a material that will diffuse its light. Items such as artist's tracing paper and photographic diffusion material are ideal. For special effects, use one auto **444D** with an accessory color filter at a higher power level than an auto **444D** without a filter.
4. For lighting a highly-reflective subject with controlled light, try the tent lighting method by simply taking heavy white paper or oak tag and bending it so the light from the unit surrounds, but won't directly hit, the subject as illustrated.

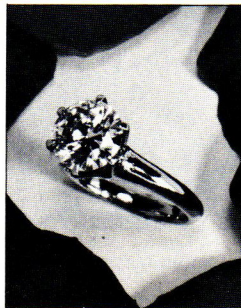
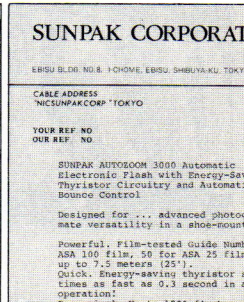

# Other Flash Hints



Multiple Exposure  
with Same Back-  
ground

Open Flash:  
Night Background  
with Fill Flash



Special Effects

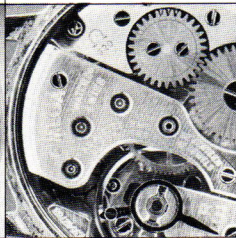

Photo Macrography

## Multiple Exposures

When shooting multiple exposures, your auto 444 D is ideal because of its multi-directional capability. Be sure to use a dark background and center your flash on each individual subject. When placing the same people in one background scene, a tripod or other rigid camera support is recommended.

## Special Effects

One of the most popular special effects today is the "Shoot" technique of superimposing one image over another. The only requirement is a roll of paper towels on a simple cardboard tube. Take the first exposure using available light and center the area of the image you wish to superimpose the image on. Then, take a second exposure on the same film, using your auto 444 D. Simply use the tube to cover all but the centered area. For smaller centering areas, use two tubes for a telescope effect. Because the light from your auto 444 D is higher than the available light in most cases, the image shot through the tube will dominate the available light image. For best results using this technique, make your superimposition on a dark area.

## Open Flash

When shooting at night, you can use your auto 444 D to act as a fill-in flash while setting your shutter speeds for background exposure. Simply push the Test (open flash) Button on your unit for one, two or more flashes while the shutter is open.

## Macro/Close-Up

By using the lower power levels on your auto 444 D, the exciting world of Macro/Close-Up photography can be mastered. Because of the lower power levels available from the auto 444 D, you can properly expose close-ups even when your flash is very close. To lower light intensity even further, bounce the light or use the diffusion filter available in the accessory filter kit.

# Multiple Flash Operation

For genuinely professional lighting effects, the only thing better than a Sunpak flash is . . . **two** Sunpaks! (Or more.) It's easy to use your Sunpak in conjunction with another auto **444 D**, or almost any other electronic flash.

## Understanding Multiple Flash

\* The 'main' flash is the one which is attached to the camera. A light-sensitive **slave unit** is attached to each of the 'remote' (other) flash units; when the main flash is fired, the other flash units are triggered — in perfect synchronization — by the slave units. The only cord involved is the one going from the 'main' flash to the camera, so you don't have to contend with wires dangling across the floor.

\* The **Sunpak Auto Slave** is a perfect partner for your multiple-flash work. It's very small, requires no batteries, and is extremely sensitive — being able to trip a remote flash even with indirect or bounce lighting at distances up to 100 feet or more. It plugs into the PC cord of the remote flash.

Although the Sunpak Slave is very sensitive to electronic flash light, it's unaffected by bright 'ambient' room light or even daylight — so your flash won't go off accidentally.

And the Sunpak Auto Slave is supplied with a handy adapter that lets you attach any shoe-mount flash to any standard tripod.



All you need is your Sunpak auto 444 D, one or more extra flash units equipped with Sunpak Slaves . . . and you're ready for professional multiple-light effects. Here's how:

1. **Arrange main and remote flash units** as desired (see diagrams on the next page).
2. **Attach Slave Units to Remote Flashes**, and PC cord of main flash to camera. Turn flashes 'On', and set each flash for **Manual** operation.
  - \* When you wish to use auto 444Ds as remote flashes, attach Standard Shoes and connect Auto Slave with PC cord.
3. **Determine the lens opening for the main flash** — the one which puts the most light on the subject. (In almost all instances, that will be the auto 444D.)
4. **Set your lens to an opening one f/stop • SMALLER** than is indicated for the flash-to-subject distance of **the Main flash** — for example, to f/11 when f/8 is indicated by your auto 444D f/stop Scale.

5. **Take The Picture!** In almost every instance, this simple technique will insure a correctly-exposed photograph.

- \* For optimum exposure accuracy in multiple flash photography, use of an electronic flash meter is suggested. This measures the total useful light of any combination of flash units, showing the exact lens opening for optimum exposure. Information on the Gossen Electronic Flash Meter system may be obtained from Sunpak dealers or from Gossen, Box 1102, Woodside, New York 11377.
- \* Do not use extension cords to trip the remote flash units. The low-voltage circuits of modern electronic flash systems often fail to trigger when long cords are employed. Slave units are more convenient and much more reliable.

\* These basic diagrams will suggest many creative potentials to the photographer. For a comprehensive analysis of professional multiple-flash technique, please refer to the publication "Professional Portrait Techniques", No. O-4H, published by the Eastman Kodak Company. Your dealer can supply you with this and other valuable books on professional lighting techniques.

Use This Arrangement

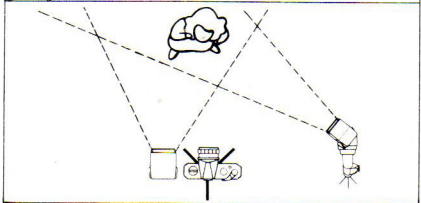
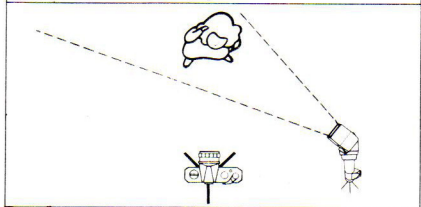
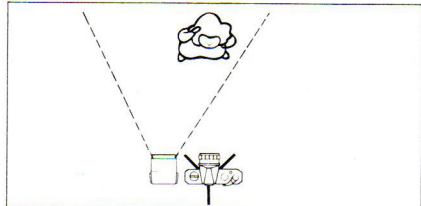

For This Effect



Use This Arrangement

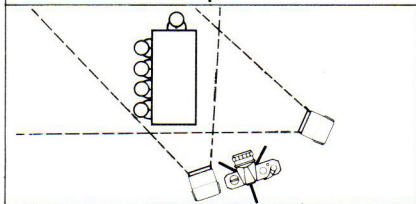
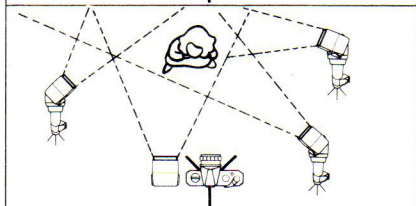
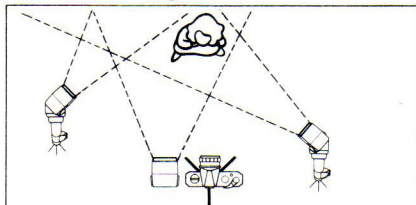

For This Effect





# Accessories Available for the Sunpak auto444 D

For maximum creativity and ease of operation, many optional accessories are available for your auto 444 D. Just like today's system cameras, you can customize your auto 444 D to suit your exact photographic requirements.

Cat. No.	Shoe Module	Interface with
651-040	CA-1D	Canon A-1, AE-1, AV-1, AL-1, NEWF-1 and AE-1 PROGRAM Cameras
651-043	MX-1D	Minolta XD, XD-S, XG-S, X-7, X-70, X-700 and LEICA R4 MOT Cameras
651-046	NE-1D	Nikon FE, EM, FG, FM-2 and F3 Cameras
651-047	RX-1D	Ricoh XR-1000S, XR-2S, XR-6, XR-S and XR-7 Cameras
651-049	OT-1D	Olympus OM-30, OM-2, OM-2N, OM-10 and OM-1N Cameras
651-041	KX-1D	Konica FS-1 and FP-1 Cameras
652-048	PX-1D	Pentax ME, ME super and LX cameras

## Sunpak Auto Slave:

Allows your auto 444 D (use with Standard Shoe STD-1D) or any flash unit with a PC Cord, to be used to trigger an auxiliary flash by plugging its PC Cord into a built-in PC socket on the slave.

Cat. No. 651-715

## Quick Detachable Interface Modules:

Full camera dedication with full electronic interfacing. Set not only the "X" sync, but much more. Sunpak one touch interchangeable interface modules are compatible with all Sunpak 'D' series Electronic Flash Systems.

## Interface Module:

- Total Dedicated Circuitry
  - Built-in Hot Shoe Contact
  - Standard Operation
- Perfect coupling for today's 35mm Electronic SLR cameras

## Standard Shoe STD-1D:

- Built-in Hot Shoe and Auto Sensor
- Detachable PC Cord (optional)
- With Remote Sensor Outlet for Sunpak Dedicated Remote Sensors (optional)

Standard Shoe STD-1D:

Cat. No. 651-042

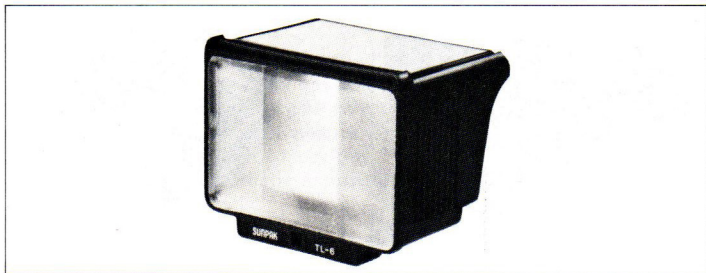

**Sunpak Tele Kit TL-8:** Ideal for use with telephoto and zoom lenses of the most popular focal lengths. The Sunpak Tele Kit actually increases light intensity while decreasing the angle of illumination. This multi position fresnel lens outfit may be used for focal length lenses from 35 to 135mm with 35mm format cameras.

Its built-in bounce flap gives your subject more vivid, lively, fill-in light. The Sunpak Tele Kit is also designed to accept the filters available in Sunpak Filter Kit FK-1.  
Tele Kit TL-8: Cat. No. 651-842

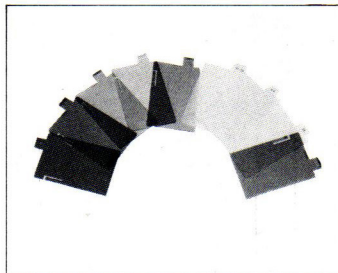

**Sunpak Filter Kit FK-1:** (Use with Sunpak Tele Kit TL-8 or Filter Holder).

Filter Kit consists of red, blue, green and yellow color filters as well as a neutral density filter, 85B color correction filter for use with tungsten film, and two wide-angle diffusers. Supplied with case.

Filter Kit FK-1: Cat. No. 651-738

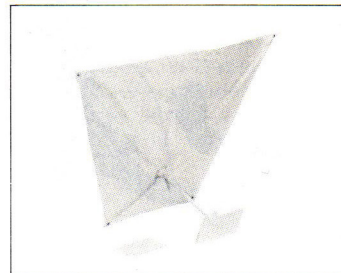

**Sunpak Bounce Lighting Kit:**

Can be used with all Sunpak models accepting Filter Holder or Tele Kit TL-8 on the flash head. Designed to give very pleasant, soft, indirect lighting effects to the subject. Weighs only 1.4 Oz.

Bounce Lighting Kit:

Cat. No. 651-795

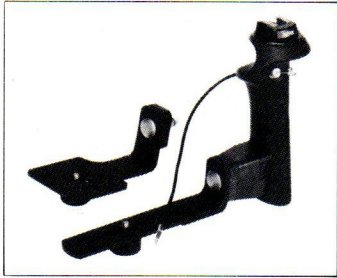

**Sunpak Basic Grip/6x6 Bracket:**

The Sunpak Basic Grip features a built-in hot shoe, contoured grip, tripod socket. Supplied with standard 12-position bracket (for use with 35mm style cameras) and PC cord. The Sunpak 6x6 Bracket can be used with basic grip when using 2 1/4 film format cameras.

Basic Grip: Cat. No. 651-772

6x6 Bracket: Cat. No. 651-752

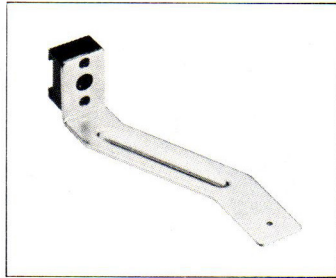

**Sunpak Bracket Extender:**

This Bracket Extender is designed to hold the remote sensor when used with cameras which do not have an accessory shoe. Use with Sunpak Basic Grip.

Sunpak Bracket Extender:

Cat. No. 651-759

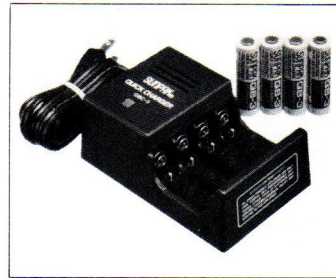

**Sunpak QBC-3 Nicad 3-Hour Charger:**

This charger is used with Sunpak QB-3 Nicad Batteries. It charges one to four batteries at a time. It will fully recharge batteries in approximately 3 hours. Sunpak QBC-3 Nicad 3-hour Charger:

Cat. No. 651-731

Sunpak QB-3 Nicad Batteries (4 pcs.):

Cat. No. 651-732



**Sunpak Multi-Voltage AC Adapter:**

The Sunpak Multi-Voltage AC Adapter (AD-27) allows you unlimited flashes.

Moreover, the world-wide voltage selector on the adapter gives you maximum convenience for your picture taking.

Cat. No. 651-740

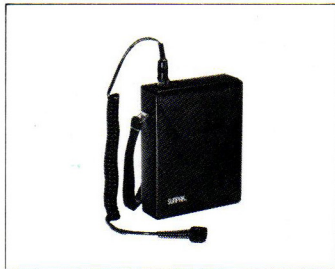

**Sunpak Powerpak for 510V Battery:**  
Allows professional 510-Volt batteries to be used for most rapid recycle times and situations where extended number of flashes is a must. Has built-in voltage regulation and detachable cord. An accessory 10' coiled cord is also available.

Sunpak Powerpak for 510V Battery:  
Cat. No. 651-723  
Sunpak 10' Coiled Cord:  
Cat. No. 651-754

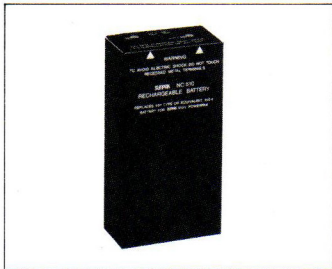

**Sunpak NC510 Rechargeable Battery for Sunpak Powerpak:** This battery provides the fastest recycle times of any available power source. The NC510 can be recharged for hundreds of cycles and provides approximately 80 to 360 flashes per charge.

Sunpak NC510 Rechargeable Battery:  
Cat. No. 651-727



**Sunpak QBC-5 Charger:**  
The Sunpak QBC-5 Charger is for use with the Sunpak NC510 Rechargeable Battery. It will fully recharge battery in approximately 10 hours.  
Sunpak QBC-5 Charger:  
Cat. No. 651-809

### **Sunpak Dedicated Remote Sensor Cord:**

Designed for the Sunpak auto 444D and Sunpak 'D' Series flash units, the Extension Cord allows the use of electronic flash off camera. Since the auto sensor unit always faces the subject, you will be assured of accurate automatic bounce for remote lighting effects with perfect exposures.

Cat. No. 651-843 for Canon  
Cat. No. 651-844 for Nikon/  
Ricoh/Minolta/Standard  
Cat. No. 651-845 for Pentax/  
Olympus/Yashica

# Inside Your auto 444 D

## Thyristor Circuitry:

Sunpak's advanced thyristor circuitry is the latest in electronic flash technology. In less-advanced automatic flash units, when the automatic sensor shuts off the flash, the circuit still expends the available energy as if a 'full' power flash had been produced. However, thyristor circuitry saves the unused energy for the next flash. This means more flashes per battery and recycling times are more rapid, depending on distances and lighting conditions.

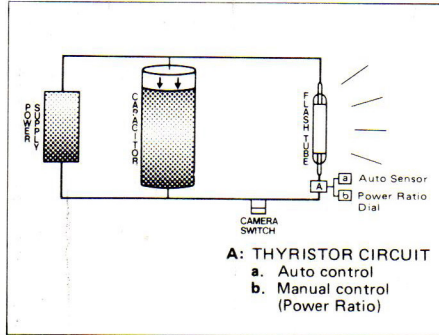

## Aged Gold-Tone Flash Tube:

Modern electronic flash units operate at speeds of 1/700th second or less. This burst of light is far shorter than the optimum exposure time today's films have. Your auto 444 D uses a unique gold-tone flash tube that has been aged and pre-flashed until critical color balance is achieved. This means your auto 444 D will give you warm, pleasing, correct color rendition with all daylight films.

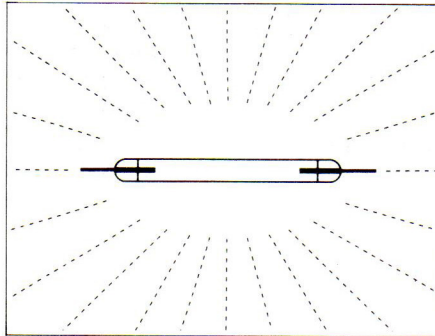

## Wide-Angle Illumination.

The use of wide-angle lenses is very popular in photography today. Your auto 444 D can be used with 35mm lenses on 35mm cameras — without any accessories. By using the wide-angle diffusers available in the accessory auto 444 D Filter Kit, lenses up to 20mm focal length on 35mm cameras may be used. By using bounce light, even wider focal length lenses may be used.

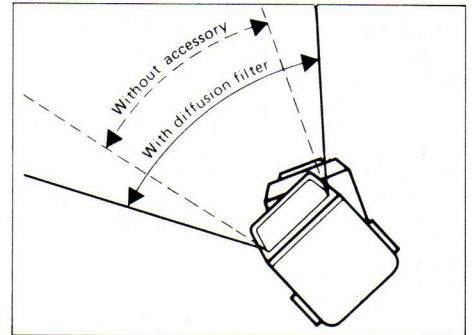

# Care of Your auto 444 D

Your Sunpak electronic flash has been engineered to require almost no "maintenance". Still to insure best performance year-in and year-out follow these basic pointers:

## 1. Storage:

When not in use, your auto 444 D should be stored in a cool dry place. Do not expose the unit to extreme heat or leave it in direct sunlight for extended periods of time. For example, do not leave the unit in the glove compartment, trunk or seat of a car.

Also, be sure to remove the batteries before storage to prevent damage due to battery leakage.

## 2. Inspect Batteries Frequently:

Check for reasonable recycling time (the length of time it takes the ready light to come on

between flashes): if it's more than 20 or 30 seconds, a fresh set of alkaline batteries should be obtained (or if nickel cadmium batteries are used, they must be recharged).

It's also wise to check your batteries for appearance: Sometimes even the best of batteries discharge or leak some chemical material through the jacket . . . and leave a whitish-powder on the battery which passes onto your Sunpak flash unit's electrical contacts. (If this has happened, replace the batteries after cleaning the Sunpak's internal battery contacts with an eraser.)

Finally, it's a good idea to remove the batteries once in a while and wipe them with a handkerchief. The cleaner the battery surface, the easier it is for the energy to pass through your flashgun's electrical system.

## 3. Remove Batteries:

If for some reason you do not intend to use your flash unit for a period of several weeks or more, remove the batteries and store them separately. Inside a plastic bag is one good way.

## 4. Maintenance:

If your auto 444 D's reflector window becomes dirty, use one drop of lens cleaner on a lens cleaning tissue. A small amount of lens cleaner and lens tissue or a slightly moist cloth can be used to clean the rest of the unit. **BE SURE TO THOROUGHLY DRY THE UNIT IMMEDIATELY AFTER CLEANING.**

## 5. Service:

In the unlikely event that your Sunpak electronic flash requires service, return it to your dealer or the sole U.S. Distributor at the

address shown on back of the Warranty Card. Do not, under any condition, attempt to disassemble and/or adjust it yourself. Electronic flash operates on high voltage and should not be taken apart. **However, keep in mind that flash failure is more likely to result from weak batteries than from any other single cause.** If it doesn't fire, check batteries and contacts carefully.

## CAUTION:

The electronic signal transfer from the camera is sent through the Interface Blade. Keep the metal positions free from dirt and grime, and protect them from scratches.

# Guide Number and "Flashmatic" Camera Operation

A "Guide Number" is simply a number expressing the power of a flash unit in relation to the sensitivity (ASA film speed) of the film in use. In use, the photographer divides the flash-to-subject distance into the Guide Number, and the result is the f/stop for correct exposure. Normally, reference to Guide Numbers is not necessary as the computer mechanism and scale of your Sunpak auto 444 D make such calculations automatically. However, there are instances in which precise Guide Number information is needed:

To determine maximum effective range in manual operation (in feet) divide the Guide Number by the aperture (f/stop).

$$\text{Distance} = \frac{\text{G.N.}}{\text{f/stop}}$$

**Guide Numbers of the auto 444 D**

Manual Power Ratio	ASA Film Speed								
	25	50	64	80	100	125	400	800	1000
Full	60	84	96	108	120	134	240	340	380
1/2	42	60	68	76	84	94	170	240	270
1/4	30	42	48	54	60	67	120	170	190
1/8	21	30	34	38	42	47	84	120	135
1/16	15	21	24	27	30	33	60	85	95

## To Use with "Flashmatic" Cameras or Lenses

Many 35mm rangefinder-type cameras (such as the Konica Auto S3) incorporate their own automatic flash exposure controls. With cameras (or lenses) of this type, the flash is set to Manual (selector switch to white symbol "M") AND THE LENS APERTURE IS AUTOMATI-

CALLY SELECTED BY THE CAMERA AS YOU FOCUS. For correct exposure with such cameras or lenses, the Guide Number for your film/flash combination must be set on the Guide Number Scale of the lens.

## Note:

- \* Specifications subject to change without notice.
- \* All specifications are based upon American National Standards Institute (ANSI) testing procedures.
- \* The number of flashes/recycling time was determined by using fresh batteries in normal room temperature under test conditions. User result may differ due to battery and temperature conditions.

# Specifications:

<b>Guide Numbers:</b>	240 (ASA 400 film), 120 (ASA 100 film) 60 (ASA 25 film)
<b>BCPS:</b>	2550 (at Full Power)
<b>Angle of Illumination:</b>	70° Horizontal by 45° Vertical; permits use of 35mm lenses on 35mm cameras, 80mm lenses on 6x6 cameras, 80mm lenses on 6x7 cameras. f/2, f/4, f/8 (ASA 100 film)
<b>Automatic Aperture Setting:</b>	6.6' – 60' (at maximum aperture)
<b>Automatic Distance Range:</b>	3.3' – 30' (at medium aperture) 1.6' – 15' (at minimum aperture)
<b>Variable Power Ratio Range:</b>	16:1, 5-stop range
<b>Sensor Acceptance Angle:</b>	15°
<b>Bounce Flash:</b>	Adjustable Bounce Flash Head at 330 degree rotation and 90 degree elevation
<b>Interchangeable Power Sources:</b>	4 x AA Nicad Batteries (optional) 4 x AA Alkaline Batteries (not included) AC: Multi-Voltage AC Adapter (AD-27) with 117/127/220/ 240V Selector (optional) Sunpak Powerpak for 510V Battery (optional) Sunpak NC510 Rechargeable Battery (optional)

## Flash Speed:

1/700th – 1/20000th second depending  
on Auto distance.

1/700th – 1/10000th second depending  
on Manual Power Ratio setting in use.

## Number of Flashes & Recycling Time:

### With AA Nicad Batteries:

Number of Flashes:

Recycling Time:

### With AA Alkaline Batteries:

Number of Flashes:

Recycling Time:

### With Sunpak Multi-Voltage

#### AC Adapter (AD-27):

Recycling Time (at 117V):

### With Sunpak Powerpak for

#### 510V Battery:

Number of Flashes:

Recycling Time:

### With Sunpak NC510

#### Rechargeable Battery:

Number of Flashes:

Recycling Time:

## Color Temperature:

## Dimensions (H x W x D):

## Weight:

Maximum Power	Minimum Power
45	370
7 sec.	0.3 sec.
100	1300
12 sec.	0.3 sec.
17 sec.	0.3 sec.
500	4500
1 sec.	0.3 sec.
80	350
1.5 sec.	0.3 sec.

Most suitable for daylight color films.

4.4"x3"x2.8" (Without shoe)

Body 11 oz (less batteries)

Shoe 1.4 oz each.

All specifications subject to change without notice.



# SUNPAK®



*SUNPAK DIVISION*

**BERKEY MARKETING COMPANIES**

**P.O. Box 1102 WOODSIDE, N.Y. 11377**

Made and printed in Japan

## **ELECTRONIC FLASH auto 444 D**

Copyright © 1983 by Sunpak Corporation. All Rights Reserved. No part of this manual may be reproduced, stored in a retrieval system, or transmitted, in any form or by any means, electronic, mechanical, photocopying, recording, or otherwise, without the prior written permission of the company.